

Product Guide 2016

for HFO / HFO Blends



R448A/R449A
R450A/R513A
R1234ze

R134a
R407A/F

R404A/507

R12/502

Preface

Many end-users, equipment and compressor manufacturers are investigating ways to minimize their impact on the environment. Improving system architectures, using a refrigerant with lower global warming potential (GWP) can significantly improve the carbon footprint of an installation.

R404A, R507, R134a are the most commonly used refrigerant in refrigeration systems (R134a also in larger chillers). However, established F-Gas regulation leads the use of refrigerants with low GWP as long term solution.

HFO pure and HFO blends with very low GWP are considered as long term refrigerants and viable alternative to natural flammable Hydro Carbon or high pressure CO₂ where the application of natural refrigerants are not favorable.

Note:

- Please see separate product guide document for use with propane.
- This document provides comprehensive technical data for selection of products required to design of system with HFO/HFO blends.
- Product Guide covers technical data for quick selection. For more detailed technical information please refer to the General Product Guide or the Technical Bulletin of individual products.

General Information

Technical data provided herein is collected with scrutiny. However, errors and misprinting remain reserved. The technical data is presented for informational purposes only and they are not to be construed as warranties or guarantees, express or implied, regarding the products or services described or their use or applicability.

Technical data may be updated; should you require confirmation with respect to a specific value, please contact Emerson Climate Technologies GmbH and clearly state the information you require.

Emerson Climate Technologies GmbH and/or its affiliates (collectively "Emerson") shall not be liable for errors in the stated capacities, dimensions, etc., as well as typographic errors. Products, specifications, designs and technical data contained in this document are subject to modification by us without prior notice. Illustrations are not binding.

Emerson does not assume responsibility for the selection, use or maintenance of any product. Responsibility for proper selection, use and maintenance of any product remains solely with the purchaser and end-user.

The information given herein is based on data and tests which Emerson Climate Technologies GmbH believes to be reliable. Such information is intended for use by individuals having the appropriate technical knowledge and skills, at their own discretion and risk. Our products are designed and adapted for stationary application. When using our products in mobile applications, our products might fail. The suitability for such mobile applications has to be assured by the plant manufacturer; for this purpose appropriate tests might be necessary.

Content

Full Solution at a Glance	4
Introduction and General Information	5
Copeland Scroll and Reciprocating Compressors	8
Electrical Control Valves.....	9
EX2 Pulse Modulated Electronic Expansion Valve.....	9
Electrical Control Valves EX4-8.....	14
Electronic Expansion Valves FX Series.....	25
Electronic Controllers and Sensors.....	30
EC3-X32 / -X33 Superheat Controller with or without TCP/IP Communication Capability.....	30
EXD-SH1/2 Controller with ModBus Communication Capability	31
Pressure Transmitter PT5	34
Fan Speed Controls.....	35
Thermo™-Expansion Valves	36
TI Series - Thermo™-Expansion Valves	37
Thermo™-Expansion Valves T-, L-, 935-, ZZ-Series.....	43
Solenoid Valves	59
2-Way Solenoid Valves Series	59
3-Way Solenoid Valves Series M36	64
Mechanical Pressure Regulators	65
ACP / CPHE - Hot Gas Bypass Regulators.....	65
Oil Management Components	66
Oil Level Management System OM3 Traxoil™	66
Oil Level Monitoring OW4 Traxoil™	68
LW4 Liquid Level Monitoring Systems.....	69
Pressure Controls	70
Pressure Controls with Adjustable Setpoints.....	70
Pressure Controls with Fixed Setpoints.....	70
System Protectors and Moisture Indicators.....	71
Hermetic Liquid Line Filter-Driers Series ADK.....	71
Filter-Driers Series FDB	72
Filter-Driers Shells Series ADKS-Plus	73
Filter-Driers Shells with Quick-Cap Series FDS-24	74
Suction Line Filters and Filter-Driers Series ASF and ASD	75
Suction Line Filters and Filter-Drier Shells Series BTAS	76
AMI / MIA Moisture / Liquid Indicators	77
Oil Separators OS Series	79
Other products.....	80
Ball Valves BVE/BVS	80
Suction Accumulators Series A	81
Saturation Pressure Table and Glide at different Suction Pressures	82

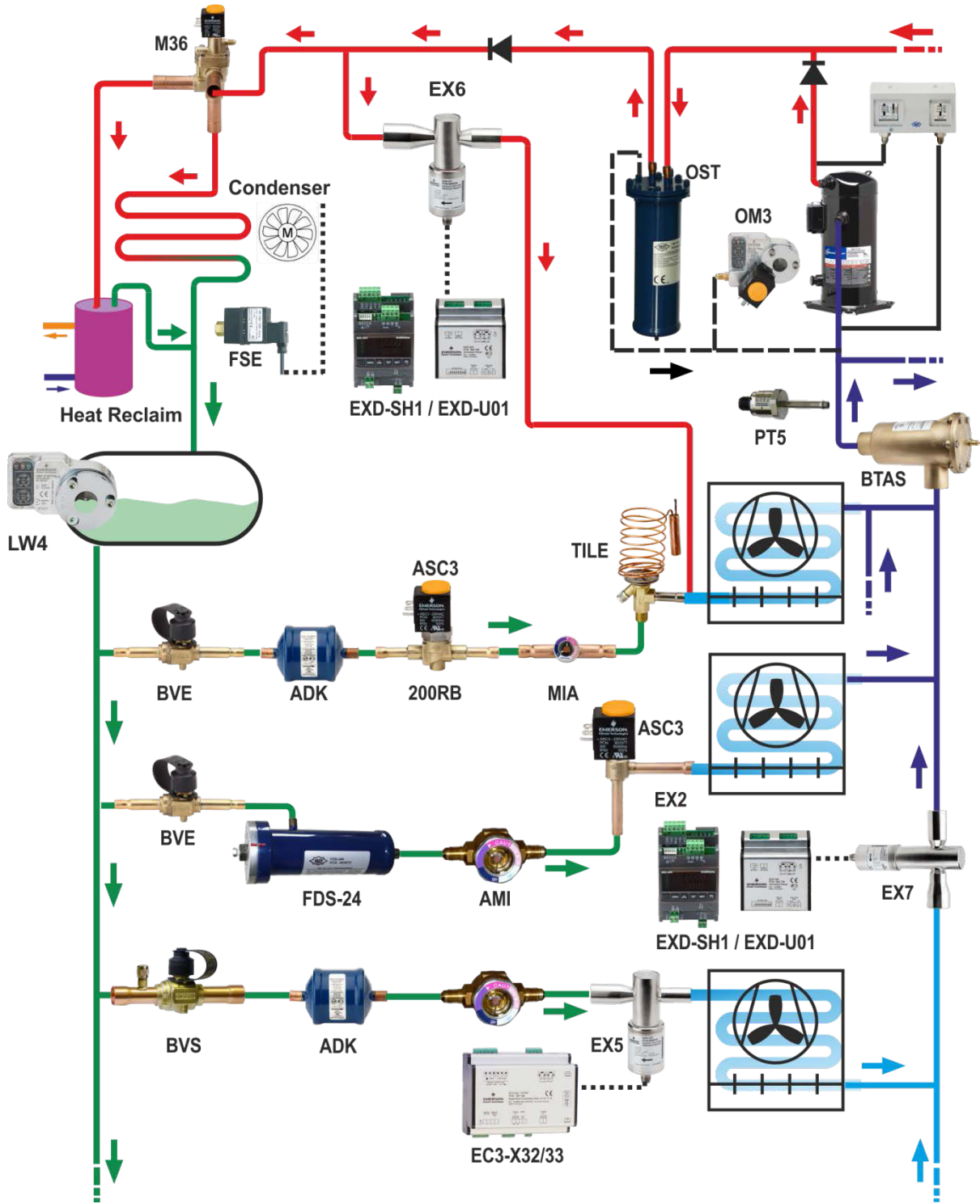

Introduction and General Information

Introduction

HFO/ HFO blends are new generation of refrigerants with low GWP as successor of HFC. The release of standard products with these new refrigerants is based on compatibility test and required modification/consideration in order to provide optimum performance.

The following subjects have been considered:

- Material compatibility of used elastomer in products
- Operating conditions in comparison with HFC refrigerant in term of pressure, temperature, enthalpy etc.
- Selection of valves based on new flow capacity resulted from refrigerant thermodynamic properties
- Software modification in electronic devices when it is required
- Behavior of Thermo™-Expansion Valves with these new refrigerant and required correction by setting or new charges

All products in this document have been qualified for use with the following refrigerants:

Refrigerant group	Refrigerant	Composition					Safety classification	Replacement for
		R1234ze	R1234yf	R32	R125	R134a		
HFO blend	R448A	7%	20%	26%	-	21%	A1	R404A, R507, R407A, R407F
	R449A	-	25.3%	24.3%	24.7%	25.7%		
	R450A	58%	-	-	-	42%		
	R513A	-	56%	-	-	44%		
HFO pure	R1234ze	100%	-	-	-	-	A2L	R134a

Note 1: As long as R1234ze is classified in A2L category, the uses of products are permitted only in non-explosive environment, non ATEX.

Note 2: All products are classified based on fluid group 2 (non-flammable) according European pressure equipment directive.

Guideline for conditional use of product in conjunction with A2L classified R1234ze refrigerant

Products	Compliance according PED		Compliance according ATEX
	Fluid group II Category	Fluid group I Category	
Mechanical devices	SEP, I or II *	Products have not been assessed/released	Zone 0, 1 and 2 Out of scope
Electrical operated devices	SEP, I or IV *		Products do not comply

Note: *) Compliance category based on connection size (valves), net volume (vessels) or safety function (pressure switches).

Capacity changes

Due to the fact of property differences between HFC and HFO/HFO blends, system designer needs to consider the impact during system design and retrofit.

Condensing temperature	30°C						40°C						50°C					
	-40	-30	-20	-10	0	10	-40	-30	-20	-10	0	10	-40	-30	-20	-10	0	10
Evaporating temperature [°C]	Expansion valve and solenoid valve capacity change from R134a/R404A to HFO/HFO-blends																	
R448A versus R404A	42%	41%	40%	40%	41%	44%	50%	47%	45%	44%	43%	44%	63%	58%	55%	52%	50%	49%
R449A versus R404A	40%	43%	44%	42%	36%	25%	37%	42%	44%	45%	43%	36%	29%	34%	39%	41%	42%	39%
R450A versus R134a	-	-5%	-3%	-4%	-8%	-17%	-	-3%	0%	1%	1%	-4%	-	-5%	0%	3%	4%	3%
R513A versus R134a	-	-2%	0%	-1%	-5%	-14%	-	-2%	1%	3%	3%	-2%	-	-7%	-2%	2%	4%	4%
R1234ze versus R134a	-	-24%	-24%	-23%	-22%	-21%	-	-25%	-24%	-23%	-22%	-21%	-	-25%	-24%	-23%	-22%	-21%

Introduction and General Information

Thermo™-Expansion Valves behavior

Standard expansion valves with optimized charges are developed for HFC however the use of these valves will not provide the same performances in term of operating superheat. There are two approaches to match the performance of valve with HFO/HFO blends:

- Readjusting the setting of valve
- New optimized charges

The following tables show TI Thermo™-Expansion Valves designed for HFC but to be used with HFO/HFO blends and required readjusting enabling to use with systems having HFO/HFO blends as refrigerant.

Adjusting stem position	Standard MW (R134a) Charge with refrigerant R1234ze					
	Evaporating temperature [°C]					
	-30	-20	-10	0	5	10
Number of Turn	Operating superheat [K]					
0	0	-0.8	-1.2	-1.5	-1.8	-2
+1	5.5	3.4	1.9	0.5	0.2	-0.2
+2	10	7	4.8	2.5	2.1	1.5
+3	14	10.2	7.2	5	4	3
+4	17.3	13.2	9.7	6.9	6	4.8

Adjusting stem position	Standard MW (R134a) Charge with refrigerant R450A					
	Evaporating temperature [°C]					
	-30	-20	-10	0	5	10
Number of Turn	Operating superheat [K]					
0	3.1	2.7	2.5	2.4	2.4	2.3
+1	8.2	6.4	5.3	4.5	4.2	3.9
+2	12.3	9.7	7.9	6.5	5.9	5.4

Adjusting stem position	Standard MW (R134a) Charge with refrigerant R513A					
	Evaporating temperature [°C]					
	-30	-20	-10	0	5	10
Number of Turn	Operating superheat [K]					
0	9.6	8.97	8.96	9	9.04	9.07
-0.5	6.8	7.3	7.8	8.1	8.2	8.3
-1	4.2	5.6	6.5	7.2	7.4	7.7
-1.5	1.5	3.8	5.2	6.2	6.6	6.9

Adjusting stem position	Standard SW (R404A) charge with refrigerant R448A					
	Evaporating temperature [°C]					
	-30	-20	-10	0	5	10
Number of Turn	Operating superheat [K]					
0	0	-1.4	-0.75	-0.1	0.9	1.4
+1	3	1.65	1.45	1.6	2.18	2.58
+2	6.5	4.3	3.6	3.2	3.4	3.6
+3	10	6.8	5.5	4.7	4.6	4.7

Note 1: number of turns in direction of clockwise as positive number and in direction of counterclockwise as negative number.

Note 2: Desired operating superheat of 6K ± 1.5K.

Note 3: Red cells are indication for low superheat below 4.5 K. Yellow cells are indicating for higher superheat above 7.5 K.

Please see section Thermo™-Expansion Valves for detailed information and guideline for readjustment.

Introduction and General Information

MOP (Maximum operating of suction pressure)

Some of HFO/HFO blends tend with lower saturating pressure at certain evaporating temperature compare to HFC. This fact extends the operating map and it might be need for Thermo™-Expansion Valves with higher MOP limit in order to allow system operation at higher suction pressure. This is advantageous for operation at high load or after defrosts.

The below example demonstrates operating envelop of identical compressor with R404A and R449A:

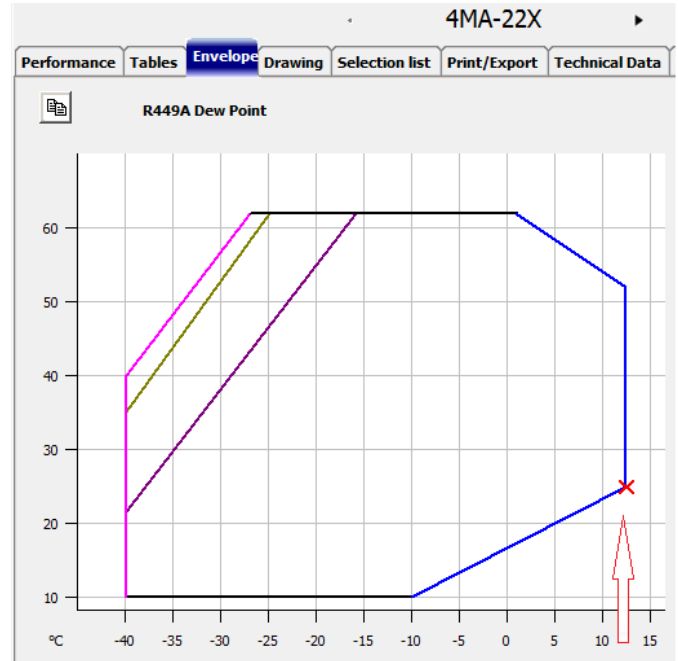
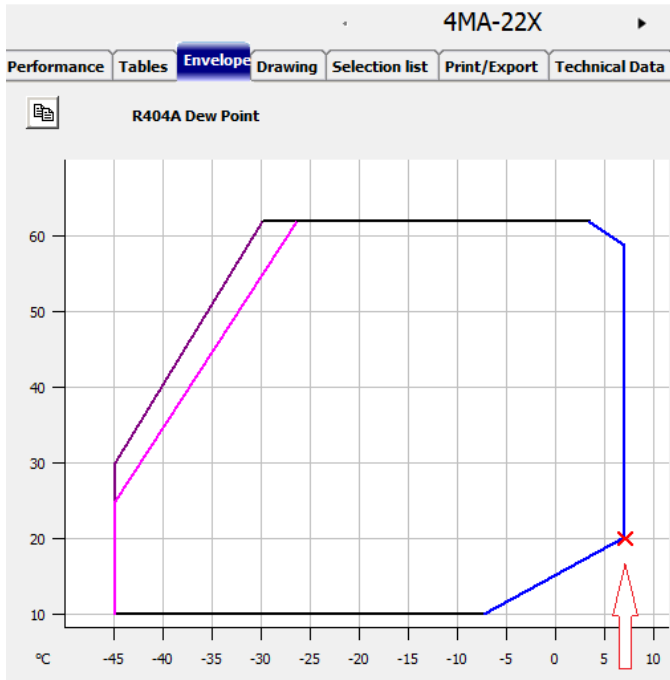

Dimensioning of Thermo®-Expansion Valves for systems with refrigerant having temperature glide

As opposed to single substances (e.g. R 134a) where the phase change takes place at a constant temperature/pressure the evaporation and condensation of zeotropic blends are in a "gliding" form (e.g. at a constant pressure the temperature varies within a certain range) through evaporators and condensers. HFO blends R448A and R449A are zeotropic blends.

The condensing /evaporating pressure must be determined at saturated temperatures (bubble for liquid / dew points for vapor) for dimensioning of the expansion valves, solenoid valves etc. The corresponding dew point for liquid pressures is provided in case of compressor selection based on dew point of liquid pressure.

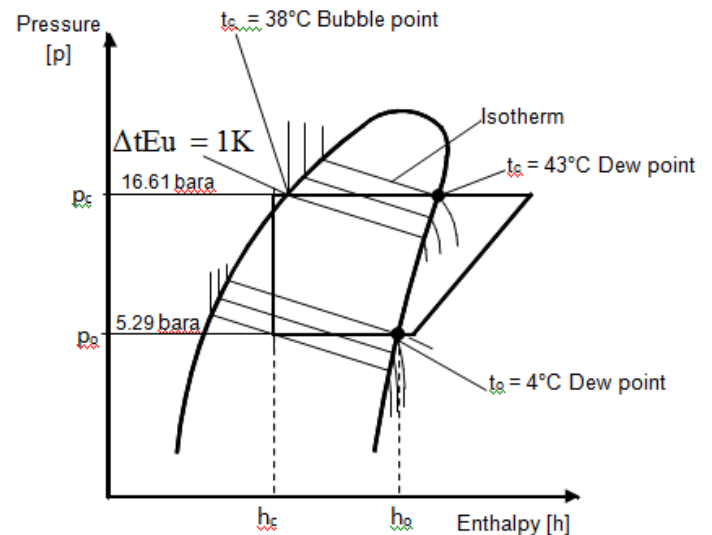

Copeland Scroll and Reciprocating Compressors

Copeland Reciprocating Compressors - Models available with R448A/R449A/R450A/R513A*

The release also applies to reciprocating compressors fitted with capacity control or operated by inverter.

2 Cylinder	3 Cylinder	8 Cylinder	Stream Models		
2DC-50x	3DA-50X	8DH-500X	4M A-22X	4M J-33X	6M I-40X
2DD-50X	3DA-75X	8DL-370X	4M F-13X	4M T-22X	6M M-30X
2DL-40X	3DC-100X	8DJ-600X	4M H-25X	4M K-35X	6M J-45X
2DL-75X	3DC-75X	8DT-450X	4M L-15X	4M U-25X	6M T-35X
2DB-50X	3DS-100X		4M I-30X		6M K-50X
2DB-75X	3DS-150X		4M M-20X		6M U-40X



Digital Models				Demand Cooling**	
3DAD-50X	4MAD-22X	4MJD-33X	6MID-40X	4MF-13X DC	
3DAD-75X	4MFD-13X	4MTD-22X	6MMD-30X	4ML-15X DC	
3DCD-100X	4MHD-25X	4MKD-35X	6MJD-45X	4MM-20X DC	
3DCD-75X	4MLD-15X	4MUD-25X	6MTD-35X	4MT-22X DC	
3DSD-100X	4MID-30x		6MKD-50X	4MU-25X DC	
3DSD-150X	4MMD-20X		6MUD-40X	6MM-30X DC	
				6MT-35X DC	
				6MU-40X DC	

Note: *) Only released for standard 4 and 6 Cylinder Stream models – Please contact Emerson for further support; **) Demand cooling applicable only with R448A/R449A

Copeland Scroll Models available with R448A/R449A

Low Temperature Models			Medium Temperature Models		
ZF Models	ZF Vapor Injection and Digital Models	ZS*KA	ZB Models	Summit	ZB Digital
ZF06K4E	ZF13KVE	ZS09KAE	ZB15KCE	ZB66K5E	ZBD21KCE
ZF08K4E	ZFD13KVE	ZS11KAE	ZB19KCE	ZB76K5E	ZBD29KCE
ZF09K4E	ZF18KVE	ZS13KAE	ZB21KCE	ZB95K5E	ZBD38KCE
ZF11K4E	ZFD18KVE		ZB26KCE	ZB114K5E	ZBD45KCE
ZF13K4E	ZFD25KVE		ZB29KCE	ZB66KCE	ZBD57KCE
ZF15K4E	ZF25K5E		ZB28KCE	ZB76KCE	ZBD76KCE
ZF18K4E	ZF34K5E		ZB42KCE	ZB95KCE	
ZF25K5E	ZF42K5E		ZB45KCE	ZB114KCE	
ZF34K5E	ZF49K5E		ZB48KCE	ZB220KCE	
ZF41K5E			ZB57KCE		
ZF49K5E					



Copeland Scroll Models available with 450A/513A

ZB Models	Summit	ZB Digital
ZB15KCE	ZB66K5E	ZBD21KCE
ZB19KCE	ZB76K5E	ZBD29KCE
ZB21KCE	ZB95K5E	ZBD38KCE
ZB26KCE	ZB114K5E	ZBD45KCE
ZB29KCE	ZB66KCE	ZBD57KCE
ZB28KCE	ZB76KCE	ZBD76KCE
ZB42KCE	ZB95KCE	
ZB45KCE	ZB114KCE	
ZB48KCE	ZB220KCE	
ZB57KCE		

Note: All the detailed compressor performance data and envelopes for R448A/R449A, R450A and R513A are now available with the release of new select version 7.11 available [online](#).

EX2 Pulse Modulated Electronic Expansion Valve

EX2 Series is an electronically controlled expansion device. The capacity is defined through pulse width modulation. The primary application is for display cases and small cold rooms in commercial refrigeration such as supermarkets.

Features

- Pulse width modulated
- Utilizing standard coils ASC3-24VAC/ 50 Hz or ASC3-230VAC/ 50 Hz (to be ordered separately)
- Shut off function eliminates the necessity of a separate solenoid valve
- Dampened plunger reduces noise and effects of water hammer
- One valve body can be combined with 6 orifices to make 7 capacity ranges, up to 17.2 kW (R 448A)
- Available with ODF connections
- Long lifetime, high reliability



EX2 with ASC3

Selection table

Type	Part No.	Description	Capacity Q_n at 100% Open Valve [kW]*				
			R448A	R449A	R450A	R513A	R1234ze
EX2-M00	801091	Valve less orifice 10 mm x 12 mm	17.2	16.8	11.7	12.0	10.4
EX2-I00	801090	Valve less orifice 3/8"x / 1/2"					
EXO-004	801089	Orifice 4	10.9	10.6	7.4	7.6	6.6
EXO-003	801088	Orifice 3	7.2	7.0	4.9	5.0	4.4
EXO-002	801087	Orifice 2	4.3	4.2	2.9	3.0	2.6
EXO-001	801086	Orifice 1	3.2	3.1	2.2	2.2	1.9
EXO-000	801085	Orifice 0	1.6	1.6	1.1	1.1	1.0
EXO-00X	801084	Orifice X	0.9	0.9	0.6	0.6	0.5
ASC3-24V	801079	Coil ASC3 24 VAC / 50 Hz					
ASC3-230V	801077	Coil ASC3-230VAC / 50 HZ					

Note: *) Orifice should be selected at maximum 80% of Q_n to allow covering the load fluctuation.

⚠ Warning: R1234ze classified as A2L. Use of product only for non-explosive environment, non ATEX zone.

The nominal capacity (Q_n) is based on the following conditions:

Refrigerant	Evaporating temperature [°C]	Condensing temperature [°C]	Subcooling
R448A, R449A	+4°C dew point	+38°C bubble / +43°C dew point	1K
R450A		+38°C bubble / +38.6°C dew point	
R513A, R1234ze		+38°C bubble / +38°C dew point	

For selection of other operating condition, please use quick selection tables on the next pages or Controls Navigator selection program.

EX2 Pulse Modulated Electronic Expansion Valve

EX2: Quick selection (included 1.5 bar pressure drop for liquid line components and distributor)

Condensing temperature [°C]	R448A/R449A													Valve/ orifice type
	Capacity [kW]													
	Evaporating temperature [°C]													
	15	10	5	0	-5	-10	-15	-20	-25	-30	-35	-40	-45	
60 bubble/ 63.4 dew point	0.64	0.64	0.64	0.64	0.64	0.64	0.64	0.64	0.64	0.64	0.56	0.56	0.56	EXO-00X
	1.20	1.20	1.20	1.20	1.20	1.20	1.12	1.12	1.12	1.04	1.04	1.04	0.96	EXO-000
	2.32	2.32	2.40	2.40	2.32	2.32	2.32	2.24	2.24	2.16	2.08	2.00	2.00	EXO-001
	3.12	3.20	3.20	3.20	3.12	3.12	3.12	3.04	2.96	2.88	2.80	2.72	2.64	EXO-002
	5.28	5.28	5.36	5.28	5.28	5.20	5.12	5.04	4.96	4.88	4.72	4.56	4.48	EXO-003
	7.92	8.00	8.08	8.08	8.00	7.92	7.84	7.68	7.52	7.36	7.12	6.96	6.72	EXO-004
	12.56	12.64	12.72	12.72	12.64	12.48	12.32	12.08	11.84	11.60	11.28	10.96	10.64	EX2-M/I
50 bubble/ 54 dew point	0.64	0.72	0.72	0.72	0.72	0.72	0.72	0.72	0.72	0.64	0.64	0.64	0.64	EXO-00X
	1.20	1.20	1.20	1.28	1.28	1.28	1.28	1.20	1.20	1.20	1.20	1.12	1.12	EXO-000
	2.40	2.40	2.48	2.48	2.48	2.48	2.48	2.40	2.40	2.40	2.32	2.32	2.24	EXO-001
	3.20	3.28	3.28	3.36	3.36	3.36	3.36	3.28	3.28	3.20	3.12	3.12	3.04	EXO-002
	5.36	5.44	5.52	5.60	5.60	5.60	5.60	5.52	5.44	5.36	5.28	5.20	5.04	EXO-003
	8.08	8.24	8.40	8.48	8.56	8.48	8.48	8.40	8.24	8.16	8.00	7.84	7.60	EXO-004
	12.72	13.04	13.28	13.36	13.44	13.44	13.36	13.20	13.04	12.80	12.56	12.32	12.00	EX2-M/I
40 bubble/ 44.5 dew point	0.64	0.64	0.64	0.72	0.72	0.72	0.72	0.72	0.72	0.72	0.72	0.64	0.64	EXO-00X
	1.12	1.20	1.20	1.20	1.28	1.28	1.28	1.28	1.28	1.28	1.20	1.20	1.20	EXO-000
	2.24	2.32	2.40	2.48	2.48	2.56	2.56	2.56	2.48	2.48	2.48	2.40	2.40	EXO-001
	2.96	3.12	3.20	3.28	3.36	3.36	3.36	3.36	3.36	3.36	3.28	3.28	3.20	EXO-002
	4.96	5.20	5.44	5.52	5.60	5.68	5.68	5.68	5.68	5.60	5.52	5.44	5.36	EXO-003
	7.52	7.92	8.16	8.40	8.48	8.56	8.64	8.56	8.56	8.48	8.32	8.24	8.08	EXO-004
	11.92	12.48	12.88	13.20	13.44	13.52	13.60	13.60	13.44	13.36	13.20	12.96	12.72	EX2-M/I
30 bubble/ 34.5 dew point	0.48	0.56	0.64	0.64	0.64	0.64	0.72	0.72	0.72	0.72	0.72	0.72	0.64	EXO-00X
	0.96	1.04	1.12	1.12	1.20	1.20	1.20	1.20	1.20	1.20	1.20	1.20	1.20	EXO-000
	1.84	2.00	2.16	2.32	2.32	2.40	2.48	2.48	2.48	2.48	2.48	2.40	2.40	EXO-001
	2.48	2.72	2.96	3.04	3.20	3.28	3.28	3.28	3.28	3.28	3.28	3.28	3.20	EXO-002
	4.16	4.56	4.88	5.12	5.28	5.44	5.52	5.52	5.52	5.52	5.52	5.44	5.36	EXO-003
	6.32	6.96	7.44	7.76	8.00	8.24	8.32	8.40	8.40	8.40	8.32	8.24	8.16	EXO-004
	9.92	10.96	11.68	12.24	12.64	12.96	13.12	13.28	13.28	13.28	13.12	13.04	12.88	EX2-M/I
20 bubble/ 25.3 dew point	0.40	0.48	0.56	0.56	0.64	0.64	0.64	0.64	0.64	0.64	0.64	0.64	0.64	EXO-00X
	0.72	0.88	0.96	1.04	1.12	1.12	1.12	1.12	1.20	1.20	1.20	1.20	1.12	EXO-000
	1.52	1.76	1.92	2.08	2.16	2.24	2.32	2.32	2.32	2.32	2.32	2.32	2.32	EXO-001
	2.00	2.32	2.56	2.80	2.88	3.04	3.12	3.12	3.12	3.12	3.12	3.12	3.12	EXO-002
	3.36	3.92	4.32	4.64	4.88	5.04	5.12	5.20	5.28	5.28	5.28	5.28	5.20	EXO-003
	5.12	5.92	6.56	7.04	7.36	7.68	7.84	7.92	8.00	8.00	7.92	7.92	7.92	EXO-004
	8.00	9.44	10.40	11.12	11.68	12.08	12.32	12.48	12.56	12.56	12.56	12.48	EX2-M/I	
10 bubble/ 15.5 dew point				0.40	0.48	0.48	0.56	0.56	0.56	0.56	0.64	0.64	0.64	EXO-00X
				0.64	0.80	0.88	0.96	1.04	1.04	1.04	1.04	1.04	1.04	EXO-000
				1.36	1.60	1.76	1.92	2.00	2.08	2.08	2.16	2.16	2.16	EXO-001
				1.76	2.16	2.40	2.56	2.72	2.80	2.80	2.88	2.88	2.88	EXO-002
				3.04	3.60	4.00	4.32	4.48	4.64	4.72	4.80	4.88	4.88	EXO-003
				4.56	5.44	6.08	6.48	6.80	7.04	7.20	7.28	7.36	7.36	EXO-004
			7.20	8.56	9.52	10.24	10.72	11.12	11.36	11.52	11.60	11.60	EX2-M/I	
0 bubble/ 5.7 dew point						0.32	0.40	0.40	0.48	0.48	0.48	0.56	0.56	EXO-00X
						0.56	0.72	0.80	0.88	0.88	0.88	0.96	0.96	EXO-000
						1.12	1.36	1.52	1.68	1.76	1.84	1.84	1.92	EXO-001
						1.52	1.84	2.08	2.24	2.40	2.48	2.56	2.56	EXO-002
						2.48	3.12	3.52	3.76	4.00	4.16	4.24	4.24	EXO-003
						3.76	4.72	5.28	5.76	6.00	6.24	6.40	6.48	EXO-004
					6.00	7.36	8.40	9.04	9.52	9.84	10.08	10.24	EX2-M/I	

EX2 Pulse Modulated Electronic Expansion Valve

EX2: Quick selection (included 1.5 bar pressure drop for liquid line components and distributor)

Condensing temperature [°C]	R450A/R513A													Valve/ orifice type
	Capacity [kW]													
	Evaporating temperature [°C]													
	15	10	5	0	-5	-10	-15	-20	-25	-30	-35	-40	-45	
60	0.48	0.48	0.48	0.48	0.48	0.48	0.48	0.48	0.40	0.40	0.40	0.40	0.40	EXO-00X
	0.88	0.88	0.88	0.88	0.88	0.80	0.80	0.80	0.80	0.72	0.72	0.72	0.64	EXO-000
	1.68	1.68	1.68	1.68	1.68	1.68	1.60	1.60	1.52	1.52	1.44	1.36	1.28	EXO-001
	2.24	2.32	2.32	2.32	2.24	2.24	2.16	2.16	2.08	2.00	1.92	1.84	1.76	EXO-002
	3.84	3.84	3.84	3.84	3.84	3.76	3.68	3.60	3.44	3.36	3.20	3.12	2.96	EXO-003
	5.76	5.84	5.84	5.84	5.76	5.68	5.52	5.44	5.28	5.04	4.88	4.64	4.48	EXO-004
	9.12	9.20	9.28	9.20	9.12	8.96	8.72	8.56	8.24	8.00	7.68	7.36	7.04	EX2-M/I
50	0.48	0.48	0.48	0.48	0.48	0.48	0.48	0.48	0.48	0.48	0.48	0.40	0.40	EXO-00X
	0.80	0.80	0.88	0.88	0.88	0.88	0.88	0.88	0.80	0.80	0.80	0.80	0.72	EXO-000
	1.60	1.68	1.68	1.68	1.76	1.76	1.68	1.68	1.68	1.60	1.60	1.52	1.44	EXO-001
	2.16	2.24	2.24	2.32	2.32	2.32	2.32	2.24	2.24	2.16	2.08	2.08	2.00	EXO-002
	3.60	3.68	3.84	3.84	3.92	3.84	3.84	3.76	3.68	3.60	3.52	3.44	3.28	EXO-003
	5.44	5.60	5.76	5.84	5.84	5.84	5.84	5.76	5.60	5.52	5.36	5.20	5.04	EXO-004
	8.56	8.88	9.12	9.20	9.28	9.28	9.20	9.04	8.88	8.64	8.40	8.16	7.92	EX2-M/I
40	0.40	0.40	0.40	0.48	0.48	0.48	0.48	0.48	0.48	0.48	0.48	0.48	0.40	EXO-00X
	0.64	0.72	0.80	0.80	0.80	0.80	0.80	0.80	0.80	0.80	0.80	0.80	0.80	EXO-000
	1.28	1.44	1.52	1.60	1.60	1.68	1.68	1.68	1.68	1.60	1.60	1.60	1.52	EXO-001
	1.76	1.92	2.08	2.16	2.24	2.24	2.24	2.24	2.24	2.16	2.16	2.08	2.08	EXO-002
	2.88	3.20	3.44	3.60	3.68	3.76	3.76	3.76	3.76	3.68	3.60	3.52	3.44	EXO-003
	4.40	4.88	5.20	5.44	5.60	5.68	5.68	5.68	5.68	5.60	5.44	5.36	5.20	EXO-004
	6.96	7.68	8.24	8.56	8.80	8.96	8.96	8.96	8.88	8.80	8.64	8.48	8.24	EX2-M/I
30	0.16	0.24	0.32	0.40	0.40	0.40	0.40	0.40	0.48	0.48	0.40	0.40	0.40	EXO-00X
	0.32	0.48	0.56	0.64	0.72	0.72	0.80	0.80	0.80	0.80	0.80	0.80	0.72	EXO-000
	0.64	0.96	1.20	1.36	1.44	1.52	1.52	1.52	1.60	1.60	1.52	1.52	1.52	EXO-001
	0.80	1.28	1.60	1.76	1.92	2.00	2.08	2.08	2.08	2.08	2.08	2.08	2.00	EXO-002
	1.36	2.16	2.64	2.96	3.20	3.36	3.44	3.52	3.52	3.52	3.52	3.44	3.44	EXO-003
	2.08	3.28	4.00	4.48	4.88	5.04	5.20	5.28	5.36	5.36	5.28	5.28	5.20	EXO-004
	3.36	5.20	6.32	7.12	7.60	8.00	8.24	8.40	8.40	8.40	8.40	8.24	8.16	EX2-M/I
20			0.08	0.24	0.32	0.32	0.32	0.40	0.40	0.40	0.40	0.40	0.40	EXO-00X
			0.16	0.40	0.48	0.56	0.64	0.64	0.72	0.72	0.72	0.72	0.72	EXO-000
			0.32	0.80	1.04	1.20	1.28	1.36	1.36	1.44	1.44	1.44	1.44	EXO-001
			0.48	1.04	1.36	1.60	1.68	1.76	1.84	1.92	1.92	1.92	1.92	EXO-002
			0.72	1.76	2.32	2.64	2.88	3.04	3.12	3.20	3.20	3.20	3.20	EXO-003
			1.12	2.72	3.44	4.00	4.32	4.56	4.72	4.80	4.80	4.88	4.80	EXO-004
			1.76	4.24	5.44	6.24	6.80	7.20	7.44	7.60	7.60	7.60	7.60	EX2-M/I
10						0.16	0.24	0.24	0.32	0.32	0.32	0.32	0.32	EXO-00X
						0.24	0.40	0.48	0.56	0.56	0.56	0.64	0.64	EXO-000
						0.48	0.80	0.96	1.04	1.12	1.20	1.20	1.20	EXO-001
						0.72	1.04	1.28	1.44	1.52	1.60	1.60	1.68	EXO-002
						1.12	1.76	2.16	2.40	2.56	2.64	2.72	2.72	EXO-003
						1.76	2.72	3.28	3.60	3.84	4.00	4.16	4.16	EXO-004
						2.72	4.24	5.12	5.68	6.08	6.32	6.48	6.56	EX2-M/I

EX2 Pulse Modulated Electronic Expansion Valve

EX2: Quick selection (included 1.5 bar pressure drop for liquid line components and distributor)

Condensing temperature [°C]	R1234ze													Valve/ orifice type
	Capacity [kW]													
	Evaporating temperature [°C]													
	15	10	5	0	-5	-10	-15	-20	-25	-30	-35	-40	-45	
60	0.40	0.40	0.40	0.40	0.40	0.40	0.40	0.40	0.40	0.40	0.40	0.32	0.32	EXO-00X
	0.72	0.80	0.80	0.80	0.80	0.72	0.72	0.72	0.72	0.64	0.64	0.64	0.64	EXO-000
	1.52	1.52	1.52	1.52	1.52	1.52	1.44	1.44	1.36	1.36	1.28	1.28	1.20	EXO-001
	2.00	2.08	2.08	2.08	2.08	2.00	2.00	1.92	1.84	1.84	1.76	1.68	1.60	EXO-002
	3.36	3.44	3.44	3.44	3.44	3.36	3.28	3.20	3.12	3.04	2.96	2.80	2.72	EXO-003
	5.12	5.20	5.28	5.20	5.20	5.12	5.04	4.88	4.80	4.64	4.48	4.32	4.08	EXO-004
	8.16	8.24	8.24	8.24	8.16	8.08	7.92	7.76	7.52	7.28	7.04	6.80	6.48	EX2-M/I
50	0.40	0.40	0.40	0.40	0.40	0.40	0.40	0.40	0.40	0.40	0.40	0.40	0.40	EXO-00X
	0.64	0.72	0.72	0.72	0.72	0.72	0.72	0.72	0.72	0.72	0.72	0.64	0.64	EXO-000
	1.36	1.44	1.44	1.44	1.52	1.52	1.44	1.44	1.44	1.36	1.36	1.36	1.28	EXO-001
	1.84	1.92	1.92	2.00	2.00	2.00	2.00	1.92	1.92	1.84	1.84	1.76	1.76	EXO-002
	3.04	3.20	3.28	3.36	3.36	3.36	3.28	3.28	3.20	3.12	3.04	2.96	2.88	EXO-003
	4.64	4.80	4.96	5.04	5.04	5.04	5.04	4.96	4.88	4.80	4.64	4.48	4.40	EXO-004
	7.28	7.60	7.84	7.92	8.00	8.00	7.92	7.84	7.68	7.52	7.36	7.12	6.88	EX2-M/I
40	0.32	0.32	0.32	0.40	0.40	0.40	0.40	0.40	0.40	0.40	0.40	0.40	0.40	EXO-00X
	0.48	0.56	0.64	0.64	0.64	0.72	0.72	0.72	0.72	0.72	0.64	0.64	0.64	EXO-000
	1.04	1.12	1.28	1.28	1.36	1.36	1.36	1.36	1.36	1.36	1.36	1.28	1.28	EXO-001
	1.36	1.52	1.68	1.76	1.84	1.84	1.84	1.84	1.84	1.84	1.84	1.76	1.76	EXO-002
	2.32	2.64	2.80	2.96	3.04	3.12	3.12	3.12	3.12	3.12	3.04	3.04	2.96	EXO-003
	3.52	3.92	4.24	4.48	4.64	4.72	4.72	4.72	4.72	4.72	4.64	4.56	4.48	EXO-004
	5.52	6.24	6.72	7.04	7.28	7.44	7.52	7.52	7.44	7.36	7.20	7.12	6.88	EX2-M/I
30	0.00	0.16	0.24	0.32	0.32	0.32	0.32	0.32	0.32	0.32	0.32	0.32	0.32	EXO-00X
	0.00	0.32	0.40	0.48	0.56	0.56	0.64	0.64	0.64	0.64	0.64	0.64	0.64	EXO-000
	0.08	0.64	0.88	1.04	1.12	1.20	1.20	1.28	1.28	1.28	1.28	1.28	1.20	EXO-001
	0.08	0.88	1.20	1.36	1.52	1.60	1.68	1.68	1.68	1.68	1.68	1.68	1.68	EXO-002
	0.16	1.44	2.00	2.32	2.48	2.64	2.72	2.80	2.80	2.80	2.80	2.80	2.72	EXO-003
	0.24	2.24	2.96	3.44	3.76	4.00	4.16	4.24	4.32	4.32	4.24	4.24	4.16	EXO-004
	0.32	3.52	4.72	5.44	6.00	6.32	6.56	6.72	6.80	6.80	6.72	6.64	6.56	EX2-M/I
20				0.08	0.16	0.24	0.24	0.32	0.32	0.32	0.32	0.32	0.32	EXO-00X
				0.16	0.32	0.40	0.48	0.48	0.56	0.56	0.56	0.56	0.56	EXO-000
				0.40	0.64	0.80	0.96	0.96	1.04	1.04	1.12	1.12	1.12	EXO-001
				0.48	0.88	1.12	1.28	1.36	1.44	1.44	1.44	1.44	1.44	EXO-002
				0.80	1.52	1.84	2.08	2.24	2.32	2.40	2.48	2.48	2.48	EXO-003
				1.28	2.24	2.80	3.20	3.44	3.52	3.68	3.68	3.76	3.68	EXO-004
				2.00	3.60	4.40	4.96	5.36	5.60	5.76	5.84	5.84	5.84	EX2-M/I
10							0.08	0.16	0.16	0.24	0.24	0.24	0.24	EXO-00X
							0.16	0.24	0.32	0.40	0.40	0.40	0.40	EXO-000
							0.32	0.56	0.64	0.80	0.80	0.88	0.88	EXO-001
							0.40	0.72	0.88	1.04	1.12	1.12	1.20	EXO-002
							0.72	1.20	1.52	1.68	1.84	1.92	1.92	EXO-003
							1.04	1.84	2.32	2.56	2.80	2.88	2.96	EXO-004
							1.60	2.96	3.68	4.08	4.40	4.56	4.64	EX2-M/I

⚠ Warning: R1234ze classified as A2L. Use of product only for non-explosive environment, non ATEX zone.

EX2 Pulse Modulated Electronic Expansion Valve

Technical data

MOPD (maximum operating pressure differential)	30 bar
Medium Temperature	-40...+50°C
Maximum Working Pressure PS	40 bar
Test Pressure PT	44 bar

Lifetime with EC2 (pulse cycle time 6 sec)	80 Million cycles life equivalent to 15 yr.
Seat leakage	< 4cc/min. Nitrogen with 10 bar differential pressure
Weight	0.25 kg

Dimensions [mm]

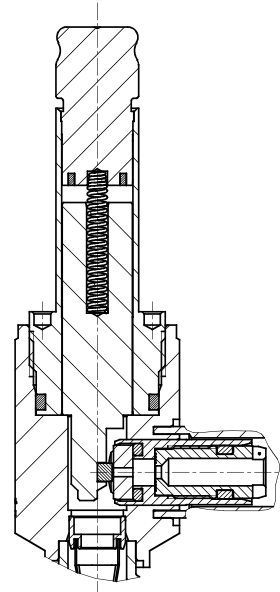
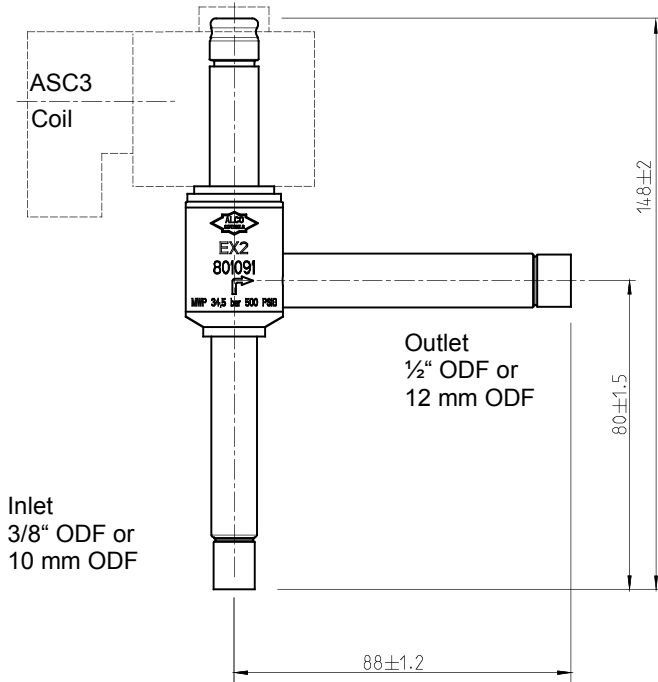

EX2 cross sectional view
(not to scale)

Electrical Control Valves EX4-8

EMERSON **EX4-8** are stepper motor driven valves for precise control of refrigerant mass flow in air conditioning, refrigeration, heat pumps, close control and industrial process cooling applications.

The Electrical Control Valves can be used as thermo-expansion duty, liquid injection duty, hot gas bypass, evaporator pressure regulator, crankcase pressure regulator, head pressure regulator or liquid level control.

Features

- Multifunction as expansion valves, hot gas bypass, suction gas throttling, head pressure, liquid level actuator etc.
- Fully hermetic design
- Stepper motor driven
- Short opening and closing time
- Very fast full stroke time
- High resolution and excellent repeatability
- Bi-flow versions with positive shut-off in both flow directions
- Positive shut-off function to eliminate the use of an additional solenoid valve
- Linear flow capacity
- Extremely wide capacity range (5...100%)
- Continuous modulation of mass flow, no stress (liquid hammering) in the refrigeration circuit
- Direct coupling of motor and valve for high reliability (no gear mechanism)
- Ceramic slide and port for accurate flow and minimal wear
- Balanced force design
- Corrosion resistant stainless steel body and connections
- Patented design



Selection table

Type	Part No.	Flow pattern	Nominal capacity range [kW]	Inlet connection	Outlet connection	Electrical connector
EX4-I21	800615	Uni-flow	5...100%	3/8" ODF	5/8" ODF	M12 plug
EX4-M21	800616			10 mm ODF	16 mm ODF	
EX5-U21	800618			5/8" (16 mm) ODF	7/8" (22 mm) ODF	
EX6-I21	800620			7/8" ODF	1-1/8" ODF	
EX6-M21	800621			22 mm ODF	28 mm ODF	
EX7-I21	800624			1-1/8" ODF	1-3/8" ODF	
EX7-M21	800625			28 mm ODF	35 mm ODF	
EX8-M21	800629			42 mm ODF	42 mm ODF	
EX8-U21	800630			1-3/8" (35 mm) ODF	1-3/8" (35 mm) ODF	
EX8-I21	800631			1-5/8" ODF	1-5/8" ODF	
EX4-U31	800617	Bi-flow (Heat pump)		5/8" (16 mm) ODF	5/8" (16 mm) ODF	
EX5-U31	800619			7/8" (22 mm) ODF	7/8" (22 mm) ODF	
EX6-I31	800622			1-1/8" ODF	1-1/8" ODF	
EX6-M31	800623			28 mm ODF	28 mm ODF	
EX7-U31	800626			1-3/8" (35 mm) ODF	1-3/8" (35 mm) ODF	

Note: The valves are delivered without cable/connector assembly (order separately).

⚠ Warning: R1234ze classified as A2L. Use of product only for non-explosive environment, non ATEX zone.

Cable and connector assembly

Type	Part No.	Temperature Range	Length	Connector type to valve	Connector type to driver board or controller	Illustration
EXV-M15	804663	-50...+80°C	1.5 m	M12	Loose wires	
EXV-M30	804664		3.0 m			
EXV-M60	804665		6.0 m			

Electrical Control Valves EX4-8

Nominal capacities...

... as expansion valves and liquid injection valves [kW] (5% ... 100%)

Valve type	R448A	R449A	R450A	R513A	R1234ze
EX4	16.5	16.1	11.3	11.5	10.0
EX5	50	49	34	35	30
EX6	120	117	82	84	73
EX7	329	321	225	230	199
EX8	877	857	600	614	532

Note 1: EX Bi-flow versions have identical capacity in both flow directions.

...as hot gas bypass regulator [kW]

Valve type	Kv [m ³ /h]	R448A	R449A	R450A	R513A	R1234ze
EX4	0.21	5.7	5.6	3.0	3.3	2.6
EX5	0.68	18.6	18.3	9.7	10.8	8.3
EX6	1.57	43.2	42.5	22.6	25.2	19.3
EX7	5.58	153.5	151.2	80.2	89.4	68.7
EX8	16.95	466.3	459.2	243.7	271.7	208.7

... as suction pressure regulator (evaporator or crankcase), [kW]

Valve type	Kv [m ³ /h]	R448A	R449A	R450A	R513A	R1234ze
EX6	1.57	3.9	3.8	2.8	3.0	2.5
EX7	5.58	13.8	13.6	9.9	10.6	9.0
EX8	16.95	42.0	41.4	30.1	32.2	27.4

... as condensing pressure regulator and liquid duty, [kW]

Valve type	Kv [m ³ /h]	R448A	R449A	R450A	R513A	R1234ze
EX5	0.68	5.4	5.2	5.3	5.1	5.1
EX6	1.57	17.4	17.0	17.2	16.5	16.6
EX7	5.58	40.4	39.6	40.1	38.3	38.7
EX8	16.95	143.6	140.7	142.5	136.2	137.6

... for hot gas flow such as heat reclaim application, [kW]

Valve type	Kv [m ³ /h]	R448A	R449A	R450A	R513A	R1234ze
EX6	1.57	9.9	9.8	7.2	7.4	6.5
EX7	5.58	35.4	34.7	25.5	26.5	23.0
EX8	16.95	106.7	105.4	77.5	80.5	69.9

The nominal capacity is based on the following conditions:

Refrigerant	Evaporating temperature [°C]	Condensing temperature [°C]	Subcooling	Pressure Drop (For suction duty)	Pressure drop (For liquid duty)	Pressure drop (For hot gas flow duty)	Isentropic efficiency (For hot gas flow duty)
R513A, R1234ze	+4°C dew point	+38°C bubble/ +38°C dew point	1K	0.15 bar	0.35 bar	0.5 bar	80%
R450A		+38°C bubble/ +38.6°C dew point					
R448A, R449A		+38°C bubble/ +42.6°C dew point					

For selection of other operating condition, please use quick selection tables in the next pages or Controls Navigator selection program.

Electrical Control Valves EX4-8

EX4-8: Quick selection (included 1.5 bar pressure drop for liquid line components and distributor)

Condensing temperature [°C]	R448A/R449A													Valve type
	Capacity [kW]													
	Evaporating temperature [°C]													
	10	5	0	-5	-10	-15	-20	-25	-30	-40	-50	-60	-70	
60 bubble/ 63.4 dew point	15	15	15	15	15	14	14	14	13	13	12	11	10	EX4
	45	45	45	44	44	43	43	42	41	38	36	33	30	EX5
	107	108	107	107	106	104	102	100	97	92	86	79	72	EX6
	295	296	295	293	290	286	281	275	268	253	236	218	199	EX7
	786	789	788	782	774	763	749	733	715	674	629	581	530	EX8
50 bubble/ 54 dew point	15	15	16	16	16	16	15	15	15	14	14	13	12	EX4
	46	47	47	47	47	47	47	46	45	43	41	39	36	EX5
	111	113	114	114	114	113	112	110	108	104	99	93	87	EX6
	305	310	312	313	313	311	308	303	298	286	271	255	238	EX7
	813	826	833	836	834	829	820	809	795	762	723	680	634	EX8
40 bubble/ 44.5 dew point	15	15	15	16	16	16	16	16	16	15	15	14	13	EX4
	44	46	47	48	48	48	48	48	47	46	44	42	40	EX5
	106	110	113	114	115	115	115	114	113	110	106	101	95	EX6
	292	302	310	314	317	317	317	315	311	302	290	276	261	EX7
	780	807	825	838	845	847	845	839	830	806	774	737	697	EX8
30 bubble/ 34.9 dew point	13	14	14	15	15	15	16	16	15	15	15	14	14	EX4
	39	42	44	45	46	47	47	47	47	46	45	43	41	EX5
	93	100	105	108	111	112	113	113	113	111	108	103	99	EX6
	257	274	288	297	304	308	310	311	310	305	296	284	272	EX7
	684	732	767	793	810	822	828	829	827	812	789	759	724	EX8
20 bubble/ 25.3 dew point	9	11	12	13	14	14	14	15	15	15	14	14	14	EX4
	29	33	37	40	42	43	44	44	45	45	44	43	41	EX5
	68	80	89	95	100	103	105	107	107	107	105	102	98	EX6
	188	221	244	261	274	283	289	293	295	294	289	281	270	EX7
	502	589	651	697	731	755	772	782	787	785	771	748	720	EX8
10 bubble/ 15.5 dew point			8	10	11	12	13	13	13	14	14	13	13	EX4
			26	30	34	36	38	40	40	41	41	40	39	EX5
			61	73	82	88	92	95	97	99	99	97	94	EX6
			169	201	224	241	253	261	267	272	271	266	258	EX7
			450	537	598	642	674	697	712	725	722	709	688	EX8
0 bubble/ 5.7 dew point					7	9	10	11	11	12	12	12	12	EX4
					21	26	30	32	34	36	37	36	36	EX5
					51	63	71	77	81	86	88	87	86	EX6
					140	174	197	213	224	237	242	240	236	EX7
					373	463	524	567	598	633	644	641	629	EX8
-10 bubble/ -4.2 dew point							5	7	8	9	10	10	10	EX4
							15	21	24	28	30	31	31	EX5
							36	50	58	68	73	74	74	EX6
							98	136	160	188	200	204	203	EX7
							262	364	427	500	534	545	542	EX8
-20 bubble/ -14.1 dew point										6	7	8	8	EX4
										17	21	23	24	EX5
										40	51	56	58	EX6
										111	141	154	159	EX7
										295	376	411	423	EX8

Electrical Control Valves EX4-8

EX4-8: Quick selection (included 1.5 bar pressure drop for liquid line components and distributor)

Condensing temperature [°C]	R450A/R513A													Valve type
	Capacity [kW]													
	Evaporating temperature [°C]													
	50	40	30	20	15	10	5	0	-5	-10	-15	-20	-30	
80	10	10	11	10	10	10	10	9	9	9	8	8	7	EX4
	30	31	32	32	31	30	30	29	28	27	25	24	22	EX5
	71	76	77	76	75	73	71	69	67	64	61	58	52	EX6
	195	208	211	209	205	201	196	190	183	176	168	160	143	EX7
	520	554	564	556	548	536	522	506	488	469	448	426	380	EX8
70	9	10	11	11	11	11	11	11	10	10	10	9	9	EX4
	27	31	33	34	34	33	33	32	32	31	30	29	27	EX5
	64	74	79	81	81	80	79	78	76	74	71	69	64	EX6
	177	204	218	222	222	220	217	213	208	203	197	190	175	EX7
	471	545	581	593	592	587	579	569	556	541	524	506	467	EX8
60	6	9	10	11	11	11	11	11	11	11	11	10	10	EX4
	18	27	31	33	34	34	34	34	33	33	32	31	30	EX5
	43	64	75	80	81	82	82	81	80	79	77	75	71	EX6
	119	177	205	220	223	224	224	223	220	216	212	207	195	EX7
	317	471	548	586	594	598	598	594	587	577	565	551	519	EX8
50		5	9	10	10	11	11	11	11	11	11	11	10	EX4
		17	26	30	32	32	33	33	33	33	33	32	31	EX5
		40	62	73	76	78	79	80	80	79	78	77	74	EX6
		109	170	200	208	214	218	219	219	218	216	212	203	EX7
		291	455	533	556	571	581	585	585	581	575	566	543	EX8
40			5	8	9	9	10	10	10	10	10	10	10	EX4
			14	24	27	29	30	31	31	32	32	31	31	EX5
			34	58	64	69	72	74	75	76	76	75	73	EX6
			93	158	176	188	197	203	206	208	208	207	202	EX7
			248	423	469	502	526	541	550	555	555	552	539	EX8
30				3	6	7	8	9	9	9	9	10	10	EX4
				10	17	21	24	26	27	28	29	29	29	EX5
				24	41	51	58	62	65	68	69	70	69	EX6
				67	114	141	159	171	180	186	190	191	191	EX7
				178	303	375	423	457	480	496	505	510	509	EX8
20							4	6	7	7	8	8	8	EX4
							13	18	20	22	24	25	26	EX5
							31	42	49	54	57	59	61	EX6
							85	116	135	148	157	163	169	EX7
							228	309	361	396	419	435	451	EX8
10									2	4	5	6	7	EX4
									5	12	16	18	20	EX5
									12	29	38	43	49	EX6
									33	80	103	118	134	EX7
									88	214	276	315	358	EX8

Electrical Control Valves EX4-8

EX4-8: Quick selection (included 1.5 bar pressure drop for liquid line components and distributor)

Condensing temperature [°C]	R1234ze													Valve type
	Capacity [kW]													
	Evaporating temperature [°C]													
	50	40	30	20	15	10	5	0	-5	-10	-15	-20	-30	
80	9	10	10	9	9	9	9	8	8	8	7	7	6	EX4
	27	29	29	29	28	27	27	26	25	24	22	21	19	EX5
	65	69	70	69	68	66	64	62	59	57	54	51	45	EX6
	180	191	193	189	186	181	176	170	163	156	148	140	123	EX7
	479	509	515	505	495	483	469	452	434	415	395	374	329	EX8
70	8	9	10	10	10	10	10	9	9	9	9	8	8	EX4
	24	28	30	30	30	30	29	29	28	27	26	25	23	EX5
	58	67	71	73	72	71	70	69	67	65	63	60	55	EX6
	158	184	196	200	199	197	193	189	184	179	173	166	152	EX7
	422	491	523	532	530	524	516	505	492	477	460	442	404	EX8
60	5	8	9	10	10	10	10	10	10	9	9	9	8	EX4
	15	23	28	30	30	30	30	30	29	29	28	27	26	EX5
	35	56	66	71	72	72	72	71	70	69	67	66	61	EX6
	97	155	182	195	198	199	198	196	193	190	185	180	169	EX7
	258	413	485	519	527	529	528	523	516	506	494	481	450	EX8
50		4	7	9	9	9	10	10	10	9	9	9	9	EX4
		13	22	26	28	28	29	29	29	29	28	28	27	EX5
		30	53	63	66	68	69	70	70	69	68	67	64	EX6
		83	146	174	182	187	190	192	191	190	187	184	176	EX7
		222	390	465	486	500	508	511	510	506	500	491	468	EX8
40			3	7	7	8	8	9	9	9	9	9	9	EX4
			9	20	23	24	26	26	27	27	27	27	26	EX5
			22	48	54	59	62	64	65	65	65	65	63	EX6
			62	132	149	161	169	175	178	179	179	178	173	EX7
			164	353	399	430	452	466	475	479	479	475	462	EX8
30				0	4	6	7	7	8	8	8	8	8	EX4
				1	13	17	20	22	23	24	24	25	25	EX5
				3	31	41	48	52	55	57	58	59	59	EX6
				9	84	113	131	143	152	157	161	162	162	EX7
				23	225	301	349	382	405	420	429	433	432	EX8
20							2	4	5	6	6	7	7	EX4
							7	13	16	18	20	20	21	EX5
							17	31	39	44	47	49	51	EX6
							48	86	106	120	129	135	140	EX7
							127	228	283	319	343	359	374	EX8
10										2	4	4	5	EX4
										6	11	13	16	EX5
										14	26	32	38	EX6
										39	71	87	105	EX7
										104	188	233	280	EX8

⚠ Warning: R1234ze classified as A2L. Use of product only for non-explosive environment, non ATEX zone.

Electrical Control Valves EX4-8

Quick selection: Suction line throttling (evaporator capacity control or crankcase pressure regulator)

Condensing temperature [°C]	Capacity [kW]												Valve type
	R448A						R449A						
	Evaporating temperature [°C]						Evaporating temperature [°C]						
	-20	-10	-5	0	5	10	-20	-10	-5	0	5	10	
30 bubble/ 34.9 dew point	26.5	33.7	37.7	41.9	46.4	51.2	26.1	33.3	37.2	41.4	45.8	50.6	EX8
	8.7	11.1	12.4	13.8	15.3	16.9	8.6	11.0	12.3	13.6	15.1	16.6	EX7
	2.5	3.1	3.5	3.9	4.3	4.7	2.4	3.1	3.4	3.8	4.2	4.7	EX6
40 bubble/ 44.5 dew point	23.7	30.3	33.9	37.8	41.9	46.3	23.3	29.8	33.4	37.2	41.3	45.6	EX8
	7.8	10.0	11.2	12.4	13.8	15.2	7.7	9.8	11.0	12.3	13.6	15.0	EX7
	2.2	2.8	3.1	3.5	3.9	4.3	2.2	2.8	3.1	3.5	3.8	4.2	EX6
50 bubble/ 54 dew point	20.7	26.6	29.9	33.4	37.1	41.1	20.3	26.2	29.4	32.8	36.5	40.4	EX8
	6.8	8.8	9.8	11.0	12.2	13.5	6.7	8.6	9.7	10.8	12.0	13.3	EX7
	1.9	2.5	2.8	3.1	3.4	3.8	1.9	2.4	2.7	3.0	3.4	3.7	EX6
60 bubble/ 63.4 dew point	17.4	22.6	25.5	28.6	31.9	35.4	17.1	22.2	25.0	28.1	31.3	34.7	EX8
	5.7	7.5	8.4	9.4	10.5	11.6	5.6	7.3	8.2	9.2	10.3	11.4	EX7
	1.6	2.1	2.4	2.6	3.0	3.3	1.6	2.1	2.3	2.6	2.9	3.2	EX6

Note: above capacities are at 0.15 bar pressure drop. For other desired pressure drop, use the correction table below.

Pressure drop [bar]	0.1	0.15	0.2	0.3
Correction factor	0.82	1	1.15	1.41

Condensing temperature [°C]	Capacity [kW]												Valve type
	R450A						R513A						
	Evaporating temperature [°C]						Evaporating temperature [°C]						
	-20	-10	-5	0	5	10	-20	-10	-5	0	5	10	
30	16.9	22.9	26.1	29.6	33.3	37.2	18.9	25.0	28.4	32.0	35.8	39.9	EX8
	5.6	7.5	8.6	9.7	11.0	12.2	6.2	8.2	9.3	10.5	11.8	13.1	EX7
	1.6	2.1	2.4	2.7	3.1	3.4	1.8	2.3	2.6	3.0	3.3	3.7	EX6
40	15.2	20.6	23.6	26.8	30.2	33.8	16.8	22.3	25.4	28.7	32.2	36.0	EX8
	5.0	6.8	7.8	8.8	9.9	11.1	5.5	7.3	8.4	9.4	10.6	11.8	EX7
	1.4	1.9	2.2	2.5	2.8	3.1	1.6	2.1	2.4	2.7	3.0	3.3	EX6
50	13.4	18.3	21.0	23.9	27.0	30.4	14.5	19.5	22.2	25.2	28.4	31.9	EX8
	4.4	6.0	6.9	7.9	8.9	10.0	4.8	6.4	7.3	8.3	9.4	10.5	EX7
	1.2	1.7	1.9	2.2	2.5	2.8	1.3	1.8	2.1	2.3	2.6	3.0	EX6
60	11.5	15.9	18.3	21.0	23.8	26.8	12.1	16.5	18.9	21.5	24.4	27.5	EX8
	3.8	5.2	6.0	6.9	7.8	8.8	4.0	5.4	6.2	7.1	8.0	9.0	EX7
	1.1	1.5	1.7	1.9	2.2	2.5	1.1	1.5	1.8	2.0	2.3	2.5	EX6

Note: above capacities are at 0.15 bar pressure drop. For other desired pressure drop, use the correction table below.

Pressure drop [bar]	0.1	0.15	0.2	0.3
Correction factor	0.82	1	1.15	1.41

Electrical Control Valves EX4-8

Quick selection: Suction line throttling (evaporator capacity control or crankcase pressure regulator)

Condensing temperature [°C]	Capacity [kW]						Valve type
	Evaporating temperature [°C]						
	-20	-10	-5	0	5	10	
30	14.9	20.5	23.6	26.8	30.3	34.0	EX8
	4.9	6.8	7.8	8.8	10.0	11.2	EX7
	1.4	1.9	2.2	2.5	2.8	3.1	EX6
40	13.4	18.5	21.3	24.3	27.5	30.9	EX8
	4.4	6.1	7.0	8.0	9.1	10.2	EX7
	1.2	1.7	2.0	2.3	2.5	2.9	EX6
50	11.8	16.4	19.0	21.7	24.6	27.8	EX8
	3.9	5.4	6.2	7.1	8.1	9.1	EX7
	1.1	1.5	1.8	2.0	2.3	2.6	EX6
60	10.1	14.3	16.5	19.0	21.7	24.5	EX8
	3.3	4.7	5.4	6.3	7.1	8.1	EX7
	0.9	1.3	1.5	1.8	2.0	2.3	EX6

Note: above capacities are at 0.15 bar pressure drop. For other desired pressure drop, use the correction table below.

⚠ Warning: R1234ze classified as A2L. Use of product only for non-explosive environment, non ATEX zone.

Pressure drop [bar]	0.1	0.15	0.2	0.3
Correction factor	0.82	1	1.15	1.41

Quick selection: Hot gas bypass

Condensing temperature [°C]	Capacity [kW]					Valve type
	R448A	R449A	R450A	R513A	R1234ze	
60 °C	7.9	7.7	4.4	4.7	3.8	EX4
	25.5	25.0	14.3	15.3	12.2	EX5
	59.3	58.2	33.2	35.5	28.4	EX6
	210.7	207.0	117.8	126.3	101.1	EX7
	640.0	628.8	358.0	383.7	307.1	EX8
50 °C	6.9	6.8	3.7	4.1	3.2	EX4
	22.4	22.1	12.1	13.3	10.4	EX5
	52.2	51.3	28.2	30.9	24.1	EX6
	185.4	182.4	100.2	109.7	85.8	EX7
	563.2	553.9	304.4	333.2	260.7	EX8
40 °C	5.9	5.8	3.1	3.5	2.7	EX4
	19.2	18.9	10.1	11.2	8.6	EX5
	44.7	44.0	23.5	26.1	20.1	EX6
	158.8	156.4	83.5	92.7	71.4	EX7
	482.4	474.9	253.6	281.7	217.0	EX8
30 °C	5.0	4.9	2.5	2.9	2.2	EX4
	16.1	15.8	8.2	9.3	7.1	EX5
	37.4	36.9	19.2	21.6	16.4	EX6
	132.9	131.0	68.1	76.7	58.4	EX7
	403.7	398.0	207.0	232.9	177.3	EX8

⚠ Warning: R1234ze classified as A2L. Use of product only for non-explosive environment, non ATEX zone.

Electrical Control Valves EX4-8

Quick selection: Heat reclaim /hot gas flow

Condensing temperature [°C]	Pressure drop [bar]	Capacity [kW]							Valve type
		R448A/R449A		Evaporating temperature [°C]			R448A/R449A		
		-40	-30	-20	-10	0	5	10	
30 bubble/ 34.9 dew point	0.1	4.0	4.2	4.4	4.7	4.9	5.0	5.1	EX6
		14.0	15.0	16.0	17.0	17.0	18.0	18.0	EX7
		43.0	45.0	48.0	50.0	53.0	54.0	55.0	EX8
	0.5	8.7	9.2	9.8	10.3	10.8	11.0	11.2	EX6
		31.0	33.0	35.0	37.0	38.0	39.0	40.0	EX7
		94.0	100.0	105.0	111.0	116.0	119.0	121.0	EX8
	1.0	12.0	12.8	13.5	14.2	14.9	15.2	15.6	EX6
		43.0	45.0	48.0	51.0	53.0	54.0	55.0	EX7
		130.0	138.0	146.0	154.0	161.0	165.0	168.0	EX8
40 bubble/ 44.5 dew point	0.1	4.0	4.3	4.5	4.8	5.1	5.2	5.3	EX6
		14.0	15.0	16.0	17.0	18.0	18.0	19.0	EX7
		43.0	46.0	49.0	52.0	55.0	56.0	57.0	EX8
	0.5	8.8	9.4	10.0	10.6	11.1	11.4	11.7	EX6
		31.0	33.0	36.0	38.0	40.0	41.0	41.0	EX7
		95.0	102.0	108.0	114.0	120.0	123.0	126.0	EX8
	1.0	12.2	13.1	13.9	14.7	15.5	15.9	16.2	EX6
		43.0	46.0	49.0	52.0	55.0	56.0	58.0	EX7
		132.0	141.0	150.0	159.0	167.0	171.0	175.0	EX8
50 bubble/ 54 dew point	0.1	3.9	4.2	4.5	4.8	5.1	5.2	5.3	EX6
		14.0	15.0	16.0	17.0	18.0	19.0	19.0	EX7
		42.0	45.0	48.0	52.0	55.0	56.0	58.0	EX8
	0.5	8.6	9.3	9.9	10.6	11.2	11.5	11.8	EX6
		30.0	33.0	35.0	38.0	40.0	41.0	42.0	EX7
		93.0	100.0	107.0	114.0	121.0	124.0	127.0	EX8
	1.0	12.0	12.9	13.8	14.7	15.6	16.0	16.4	EX6
		43.0	46.0	49.0	52.0	55.0	57.0	58.0	EX7
		129.0	139.0	149.0	159.0	169.0	173.0	178.0	EX8
60 bubble/ 63.4 dew point	0.1	3.6	3.9	4.2	4.6	4.9	5.0	5.2	EX6
		13.0	14.0	15.0	16.0	17.0	18.0	18.0	EX7
		39.0	42.0	46.0	49.0	53.0	54.0	56.0	EX8
	0.5	7.9	8.7	9.4	10.1	10.8	11.2	11.5	EX6
		28.0	31.0	33.0	36.0	38.0	40.0	41.0	EX7
		86.0	94.0	102.0	109.0	117.0	121.0	124.0	EX8
	1.0	11.1	12.1	13.2	14.2	15.1	15.6	16.1	EX6
		39.0	43.0	47.0	50.0	54.0	55.0	57.0	EX7
		120.0	131.0	142.0	153.0	163.0	168.0	173.0	EX8

Electrical Control Valves EX4-8

Quick selection: Heat reclaim /hot gas flow

Condensing temperature [°C]	Pressure drop [bar]	R450A/R513A Capacity [kW]							Valve type
		Evaporating temperature [°C]							
		-40	-30	-20	-10	0	5	10	
30	0.1	2.8	3.0	3.2	3.4	3.5	3.6	3.7	EX6
		10.0	10.6	11.3	11.9	12.6	12.9	13.2	EX7
		30.2	32.3	34.3	36.2	38.1	39.0	40.0	EX8
	0.5	6.1	6.5	6.9	7.2	7.6	7.8	8.0	EX6
		21.5	23.0	24.4	25.8	27.1	27.8	28.4	EX7
		65.4	69.8	74.1	78.3	82.3	84.3	86.3	EX8
	1.0	8.2	8.7	9.3	9.8	10.3	10.5	10.8	EX6
		29.1	31.0	32.9	34.8	36.6	37.5	38.3	EX7
		88.4	94.3	100.0	105.7	111.2	113.9	116.5	EX8
40	0.1	2.9	3.1	3.3	3.5	3.7	3.8	3.9	EX6
		10.2	11.0	11.7	12.5	13.2	13.6	13.9	EX7
		31.0	33.4	35.7	37.9	40.2	41.2	42.3	EX8
	0.5	6.3	6.7	7.2	7.6	8.1	8.3	8.5	EX6
		22.2	23.9	25.6	27.2	28.8	29.5	30.3	EX7
		67.6	72.6	77.7	82.6	87.4	89.7	92.0	EX8
	1.0	8.6	9.2	9.8	10.4	11.0	11.3	11.6	EX6
		30.4	32.7	34.9	37.1	39.2	40.3	41.3	EX7
		92.3	99.2	106.0	112.7	119.2	122.4	125.5	EX8
50	0.1	2.9	3.1	3.4	3.6	3.8	3.9	4.1	EX6
		10.2	11.1	11.9	12.8	13.6	14.0	14.4	EX7
		30.9	33.6	36.2	38.8	41.4	42.6	43.9	EX8
	0.5	6.3	6.8	7.3	7.9	8.4	8.6	8.9	EX6
		22.3	24.2	26.1	28.0	29.8	30.7	31.6	EX7
		67.6	73.5	79.3	85.0	90.5	93.2	95.9	EX8
	1.0	8.6	9.4	10.1	10.8	11.5	11.9	12.2	EX6
		30.6	33.3	35.9	38.4	40.9	42.2	43.4	EX7
		93.0	101.0	109.0	116.8	124.4	128.1	131.7	EX8
60	0.1	2.7	3.0	3.3	3.6	3.9	4.0	4.1	EX6
		9.7	10.8	11.8	12.7	13.7	14.2	14.7	EX7
		29.6	32.7	35.7	38.7	41.6	43.1	44.5	EX8
	0.5	6.0	6.6	7.3	7.9	8.5	8.8	9.0	EX6
		21.4	23.6	25.8	28.0	30.1	31.1	32.1	EX7
		65.0	71.7	78.4	84.9	91.4	94.5	97.6	EX8
	1.0	8.3	9.2	10.0	10.9	11.7	12.1	12.5	EX6
		29.6	32.6	35.6	38.6	41.5	42.9	44.3	EX7
		89.9	99.1	108.3	117.3	126.1	130.4	134.7	EX8

Electrical Control Valves EX4-8

Quick selection: Heat reclaim /hot gas flow

Condensing temperature [°C]	Pressure drop [bar]	R1234ze Capacity [kW]							R1234ze	Valve type
		Evaporating temperature [°C]								
		-40	-30	-20	-10	0	5	10		
30	0.1	2.5	2.7	2.9	3.0	3.2	3.3	3.4	EX6	
		9.0	9.6	10.2	10.8	11.4	11.6	11.9	EX7	
		27.4	29.2	31.0	32.7	34.5	35.4	36.2	EX8	
	0.5	5.4	5.8	6.2	6.5	6.9	7.0	7.2	EX6	
		19.3	20.7	21.9	23.1	24.4	25.0	25.6	EX7	
		58.7	62.7	66.5	70.3	74.1	75.9	77.8	EX8	
	1.0	7.3	7.8	8.2	8.7	9.2	9.4	9.6	EX6	
		25.9	27.7	29.3	31.0	32.6	33.5	34.3	EX7	
		78.7	84.0	89.1	94.1	99.2	101.7	104.1	EX8	
40	0.1	2.6	2.8	3.0	3.2	3.4	3.5	3.6	EX6	
		9.2	9.9	10.6	11.3	12.0	12.3	12.6	EX7	
		28.0	30.2	32.2	34.3	36.3	37.4	38.4	EX8	
	0.5	5.6	6.1	6.5	6.9	7.3	7.5	7.7	EX6	
		20.0	21.5	23.0	24.5	25.9	26.6	27.4	EX7	
		60.7	65.4	69.8	74.3	78.7	80.9	83.1	EX8	
	1.0	7.6	8.2	8.8	9.3	9.9	10.2	10.4	EX6	
		27.1	29.2	31.2	33.2	35.2	36.1	37.1	EX7	
		82.4	88.7	94.7	100.8	106.8	109.8	112.7	EX8	
50	0.1	2.6	2.8	3.0	3.3	3.5	3.6	3.7	EX6	
		9.2	10.0	10.8	11.6	12.3	12.7	13.1	EX7	
		27.9	30.3	32.7	35.1	37.5	38.7	39.8	EX8	
	0.5	5.6	6.1	6.6	7.1	7.6	7.8	8.0	EX6	
		20.0	21.8	23.5	25.2	26.9	27.7	28.6	EX7	
		60.8	66.2	71.3	76.5	81.7	84.3	86.8	EX8	
	1.0	7.7	8.4	9.0	9.7	10.4	10.7	11.0	EX6	
		27.4	29.8	32.1	34.5	36.8	37.9	39.1	EX7	
		83.2	90.5	97.6	104.7	111.7	115.3	118.7	EX8	
60	0.1	2.5	2.7	3.0	3.2	3.5	3.6	3.7	EX6	
		8.8	9.7	10.6	11.5	12.4	12.9	13.3	EX7	
		26.6	29.5	32.2	35.0	37.7	39.1	40.5	EX8	
	0.5	5.4	6.0	6.5	7.1	7.6	7.9	8.2	EX6	
		19.2	21.3	23.2	25.2	27.2	28.2	29.1	EX7	
		58.4	64.6	70.6	76.6	82.6	85.6	88.5	EX8	
	1.0	7.4	8.2	9.0	9.8	10.5	10.9	11.3	EX6	
		26.5	29.3	32.0	34.7	37.4	38.7	40.1	EX7	
		80.4	88.9	97.1	105.3	113.6	117.7	121.7	EX8	

⚠ Warning: R1234ze classified as A2L. Use of product only for non-explosive environment, non ATEX zone.

Technical data EX4-8 valves

MOPD (maximum operating pressure differential)	EX4-6: 40 bar EX7: 35 bar EX8: 30 bar
Max. allowable working pressure, PS	EX4-7: 60 bar EX8: 45 bar
Evaporating temperature	-100...+55°C
Ambient temperature	-40...+55°C
Storage temperature	-40...+70°C
Medium inlet temperature	
Bi-flow version:	TS: -40...+80°C
Uni-flow version	TS: -50...+100°C
Vibration for non-connected and fastened valve	4g (0...1000 Hz, 1 octave /min.)
Marking	

Protection accordance to IEC 529, DIN 40050	IP67 with EMERSON supplied cable connector assembly
Connections/Material	ODF stainless steel fittings
Shock	20g at 11 ms 80g at 1 ms
Net weight (kg)	0.5 kg (EX4), 0.52 kg (EX5), 0.60 kg (EX6), 1.1 kg (EX7) 1.5 kg (EX8)
Seat leakage	Positive shut-off better than solenoid valves
Humidity	5...95% r.H.
Package / delivery (individual)	without electrical connector

Electrical Control Valves EX4-8

Electrical data EX4-8 valves

Stepper motor type	Bi-polar, phase current by chopper control (constant current)
Electrical connection	4 pin terminal via plug
Nominal supply voltage to the valve U:	24 VDC
Driver supply voltage range	18...36 VDC
Phase current, operating	EX4-6: 500 mA EX7: 750 mA EX8: 800 mA $\pm 10\%$
Holding current	EX4-6: 100 mA EX7: 250 mA EX8: 500 mA
Nominal input power per phase	EX4/EX5/EX6: 3.5 W EX7/EX8: 5 W

Step mode	2 phase full step, half step or microstep
Step angle	1.8° per step $\pm 8\%$
Stepping rate	500 Hz
Total number of steps	EX4-6: 750 full steps EX7: 1600 full steps EX8: 2600 full steps
Winding resistance per phase	EX4-6: 13 Ohm $\pm 10\%$ EX7: 8 Ohm $\pm 10\%$ EX8: 6 Ohm $\pm 10\%$
Full travel time	EX4-6: 1.5 seconds EX7: 3.2 seconds EX8: 5.2 seconds
Reference position	Mechanical stop at fully closed position

Dimensions [mm]

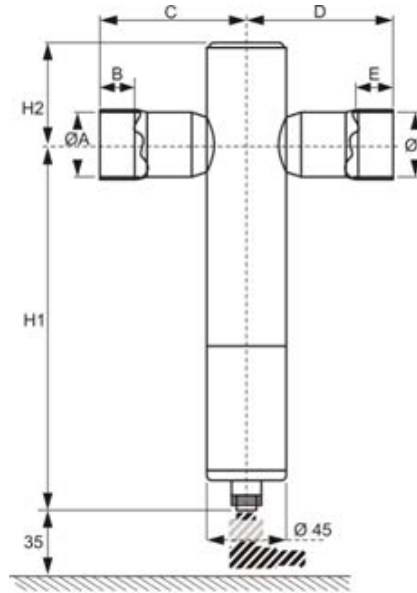
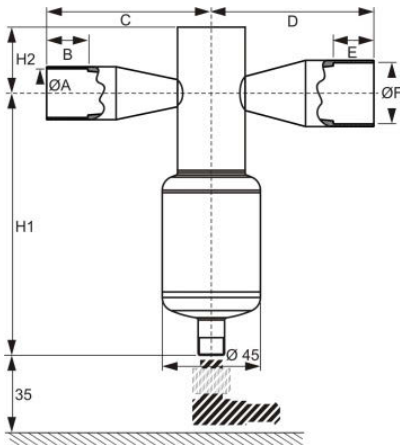

Type	Flow pattern	Part No.	Ø A x Ø F(ODF)	B	C	D	E	H1	H2
EX4-I21	Uni-flow	800615	3/8" x 5/8"	8	45	55	11	113	25
EX4-M21		800616	10 x 16 mm	8	45	55	11	113	25
EX5-U21		800618	5/8" x 7/8" (16 x 22 mm)	11	55	65	16	113	25
EX6-I21		800620	7/8" x 1-1/8"	16	65	75	19	113	25
EX6-M21		800621	22 x 28 mm	16	65	75	19	113	25
EX7-I21		800624	1-1/8" x 1-3/8"	20	78	83	20	158	42
EX7-M21		800625	28 x 35 mm	20	78	83	20	158	42
EX8-M21		800629	42 x 42 mm	20	80	80	20	200	56
EX8-U21		800630	1-3/8" (35 mm) x 1-3/8" (35 mm)	20	80	80	20	200	56
EX8-I21		800631	1-5/8" x 1-5/8"	20	80	80	20	200	56
EX4-U31	Bi-flow	800617	5/8" x 5/8" (16 x 16 mm)	11	55	55	11	113	25
EX5-U31		800619	7/8" x 7/8" (22 x 22 mm)	16	65	65	16	113	25
EX6-I31		800622	1-1/8" x 1-1/8"	19	75	75	19	113	25
EX6-M31		800623	28 x 28 mm	19	75	75	19	113	25
EX7-U31		800626	1-1/8"(35 mm) x 1-1/8" (35 mm)	23	83	83	23	158	42

Electronic Expansion Valves FX Series

Emerson **FX** are stepper motor driven electronic expansion valves for precise control of refrigerant mass flow in air conditioning, heat pumps, close control and industrial process cooling applications.

Features

- Flexibility by configuration of outlet connection in 4 directions
- Stepper motor driven
- High resolution and excellent repeatability
- Linear flow capacity
- Extremely wide capacity range (10...100%)
- Continuous modulation of mass flow, no stress (liquid hammering) in the refrigeration circuit
- Direct coupling of motor and valve for high reliability (no gear mechanism)



FX7

Selection table

Type	Part No.	Inlet connection ODF	Outlet connection ODF	Electric connection
FX5-U07	801336	7/8"	7/8"	Suitable for M12 plug (order separately)
FX6-I09	801337	1-1/8"	1-1/8"	
FX6-M28	801338	28 mm	28 mm	
FX6.5-I09	801339	1-1/8"	1-1/8"	
FX6.5-M28	801340	28 mm	28 mm	
FX7-U11	801341	1-3/8"	1-3/8"	
FX7.5-U11		1-3/8"	1-3/8"	
FX8-I13		1-5/8"	1-5/8"	
FX8-M42		42 mm	42 mm	
FX9-U17		2-1/8"	2-1/8"	

⚠ Warning: R1234ze classified as A2L. Use of product only for non-explosive environment, non ATEX zone.

Cable and connector assembly

Type	Part No.	Temperature Range	Length	Connector type to valve	Connector type to driver board or controller	Illustration
EXV-M15	804663	-50...+80°C	1.5 m	M12	Loose wires	
EXV-M30	804664		3.0 m			
EXV-M60	804665		6.0 m			

Nominal capacities [kW]

Valve Type	R450A	R513A	R1234ze
FX5	27.3	27.9	31.3
FX6	65	66	74
FX6.5	99	101	113
FX7	211	216	242
FX7.5	314	321	360
FX8	498	510	571
FX9	1159	1187	1329

Note: Nominal capacity of FX7.5, FX8 and FX9 might be modified. Please contact local sales office for confirmation.

The nominal capacity is based on the following conditions:

Refrigerant	Evaporating temperature [°C]	Condensing temperature [°C]	Subcooling
R513A, R1234ze	+4°C	+38°C bubble/ +38°C dew point	1K
R450A	+4°C dew point	+38°C bubble/ +38.6°C dew point	

For selection of other operating condition, please use quick selection tables in the next pages or Controls Navigator selection program.

Electronic Expansion Valves FX Series

FX: Quick selection (included 1.5 bar pressure drop for liquid line components and distributor)

Condensing temperature [°C]	R450A/R513A													Valve type
	Capacity [kW]													
	Evaporating temperature [°C]													
	50	40	30	20	15	10	5	0	-5	-10	-15	-20	-30	
80	24	25	26	25	25	24	24	23	22	21	20	19	17	FX5
	56	60	61	60	59	58	56	55	53	51	48	46	41	FX6
	86	91	93	92	90	88	86	83	80	77	74	70	63	FX6.5
	183	195	199	196	193	189	184	178	172	165	158	150	134	FX7
	272	290	295	291	286	280	273	264	255	245	234	223	199	FX7.5
	431	460	468	462	454	445	433	420	405	389	372	354	316	FX8
	1005	1070	1089	1075	1058	1035	1008	977	943	906	866	824	735	FX9
70	21	25	26	27	27	27	26	26	25	25	24	23	21	FX5
	51	59	63	64	64	63	63	61	60	58	57	55	50	FX6
	78	90	96	98	98	97	95	94	92	89	86	83	77	FX6.5
	166	192	205	209	209	207	204	200	196	190	185	178	164	FX7
	246	285	304	310	309	307	303	297	290	283	274	265	244	FX7.5
	391	452	482	492	491	487	481	472	461	449	435	420	387	FX8
	910	1053	1123	1146	1144	1134	1119	1098	1073	1045	1012	978	901	FX9
60	14	21	25	27	27	27	27	27	27	26	26	25	24	FX5
	34	51	59	63	64	65	65	64	63	62	61	59	56	FX6
	52	78	90	96	98	99	99	98	97	95	93	91	86	FX6.5
	112	166	193	206	209	211	211	209	207	203	199	194	183	FX7
	165	246	286	306	311	313	313	310	307	302	295	288	271	FX7.5
	263	391	455	486	493	496	496	493	487	479	469	457	431	FX8
	611	910	1058	1131	1148	1156	1155	1147	1133	1114	1091	1065	1003	FX9
50	13	21	24	25	26	26	27	27	27	26	26	26	25	FX5
	31	49	58	60	62	63	63	63	63	63	62	61	59	FX6
	48	75	88	92	94	96	96	96	96	96	95	93	89	FX6.5
	103	160	188	196	201	205	206	206	206	205	203	199	191	FX7
	152	238	279	291	299	303	306	306	304	301	296	296	284	FX7.5
	242	377	442	461	474	482	485	485	482	477	470	470	450	FX8
	563	878	1030	1074	1104	1122	1130	1130	1123	1111	1094	1094	1048	FX9
40	11	19	21	23	24	25	25	25	25	25	25	25	24	FX5
	27	46	51	54	57	58	59	59	60	60	60	60	58	FX6
	41	70	77	83	87	89	89	91	91	91	92	91	89	FX6.5
	87	149	165	177	185	191	194	195	195	196	196	195	190	FX7
	130	221	245	263	275	283	288	290	290	290	289	289	282	FX7.5
	206	351	389	417	436	449	457	460	461	461	458	458	447	FX8
	479	816	907	971	1015	1045	1063	1072	1073	1073	1067	1067	1041	FX9
30	8	14	17	19	21	22	23	23	23	23	23	23	23	FX5
	19	33	40	46	49	52	54	55	55	55	55	55	55	FX6
	29	50	62	70	75	79	82	83	83	84	84	84	84	FX6.5
	63	107	132	149	161	169	175	178	180	180	180	179	179	FX7
	93	159	196	221	239	251	259	264	267	267	267	266	266	FX7.5
	148	252	311	351	379	398	411	419	423	423	423	422	422	FX8
344	586	724	818	883	928	958	976	985	985	985	983	983	FX9	
20	10	14	16	18	19	20	20	20	20	20	20	20	20	FX5
	25	33	39	43	45	47	49	49	49	49	49	49	49	FX6
	37	51	59	65	69	72	74	74	74	74	74	74	74	FX6.5
	80	109	127	139	148	153	159	159	159	159	159	159	159	FX7
	119	162	188	207	219	228	236	236	236	236	236	236	236	FX7.5
	189	256	299	328	348	361	374	374	374	374	374	374	374	FX8
440	597	697	764	810	841	870	870	870	870	870	870	870	FX9	

Electronic Expansion Valves FX Series

FX: Quick selection (included 1.5 bar pressure drop for liquid line components and distributor)

Condensing temperature [°C]	R1234ze													Valve type
	Capacity [kW]													
	Evaporating temperature [°C]													
	50	40	30	20	15	10	5	0	-5	-10	-15	-20	-30	
80	28	30	30	30	29	28	28	27	26	24	23	22	19	FX5
	67	71	72	71	69	67	65	63	61	58	55	52	46	FX6
	102	108	110	108	106	103	100	96	93	88	84	80	70	FX6.5
	218	232	235	230	226	220	214	206	198	189	180	170	150	FX7
	324	344	348	341	335	327	317	306	294	281	267	253	222	FX7.5
	514	546	552	542	531	518	503	485	466	446	424	401	353	FX8
	1197	1271	1287	1262	1237	1207	1171	1130	1086	1037	987	933	821	FX9
70	25	29	31	31	31	31	30	30	29	28	27	26	24	FX5
	59	69	73	74	74	73	72	70	69	67	64	62	56	FX6
	90	105	112	113	113	112	110	108	105	102	98	94	86	FX6.5
	192	224	238	242	241	239	235	230	224	217	210	202	184	FX7
	285	332	354	360	358	354	349	341	332	322	311	299	273	FX7.5
	453	527	562	571	568	562	553	541	527	511	494	475	434	FX8
	1055	1228	1308	1329	1324	1310	1288	1261	1228	1191	1150	1106	1010	FX9
60	15	24	29	31	31	31	31	31	30	30	29	28	26	FX5
	36	58	68	73	74	74	74	73	72	71	69	67	63	FX6
	55	88	103	111	112	113	113	112	110	108	105	102	96	FX6.5
	118	188	221	237	240	241	241	238	235	231	225	219	205	FX7
	175	279	328	351	356	358	357	354	349	342	334	325	304	FX7.5
	277	443	521	557	565	568	567	562	553	543	530	516	482	FX8
	645	1032	1213	1297	1316	1323	1319	1308	1289	1264	1234	1201	1123	FX9
50		13	23	27	29	29	30	30	30	30	29	29	28	FX5
		31	54	65	68	70	71	71	71	71	70	69	65	FX6
		47	83	99	104	106	108	109	109	108	107	105	100	FX6.5
		101	178	212	221	228	231	233	232	231	228	224	213	FX7
		150	264	314	328	338	343	345	345	342	338	332	317	FX7.5
		239	418	498	521	536	545	548	547	543	536	527	502	FX8
		556	974	1161	1214	1248	1268	1276	1275	1265	1249	1227	1170	FX9
40			10	21	23	25	27	27	28	28	28	28	27	FX5
			23	49	56	60	63	65	66	67	67	66	65	FX6
			35	75	85	92	96	99	101	102	102	101	98	FX6.5
			75	161	182	196	206	212	216	218	218	217	211	FX7
			111	239	269	291	306	315	321	323	324	321	312	FX7.5
			176	379	428	462	485	500	509	513	513	510	496	FX8
			410	882	996	1075	1129	1165	1186	1196	1196	1188	1155	FX9
30				1	13	18	21	22	24	25	25	25	25	FX5
				3	31	42	49	53	57	59	60	60	60	FX6
				5	48	64	74	81	86	89	91	92	92	FX6.5
				10	102	137	159	174	184	191	195	197	197	FX7
				15	152	203	236	259	274	284	290	293	292	FX7.5
				25	241	323	375	410	434	450	460	465	463	FX8
				57	561	752	873	955	1012	1049	1071	1082	1078	FX9
20							7	13	17	19	20	21	22	FX5
							18	32	40	45	48	50	52	FX6
							27	49	60	68	73	77	80	FX6.5
							58	104	129	145	156	164	170	FX7
							86	154	192	216	232	243	253	FX7.5
							136	245	304	342	368	385	401	FX8
							317	570	708	798	858	897	935	FX9

⚠ Warning: R1234ze classified as A2L. Use of product only for non-explosive environment, non ATEX zone.

Electronic Expansion Valves FX Series

Bi-flow application

FX valves are able to be operated in Bi-flow direction such as reversible heat pump with following consideration:

Type	Max. Operating differential [bar]	
	Normal flow direction	Reverse flow direction
FX5	40	30
FX6	35	30
FX6.5	35	30
FX7	35	35

Note: Identical flow capacity in normal and reverse flow direction.

Technical data

CE marking FX5/6/6.5: FX7/7.5/8/9:	not required required, Cat I, Module A
MOPD (maximum operating pressure differential)	FX5: 40 bar FX6-8: 35 bar FX9: 28 bar
Max. working pressure PS	FX5-8: 46 bar FX9: 35 bar
Ambient temperature	-40...+55°C
Storage temperature	-40...+70°C
Medium inlet temperature	TS: -35...+75°C
Approval	us (pending) EAC (pending)

Protection accordance to IEC 529, DIN 40050	IP67 with EMERSON EXV-Mxx plug and cable assembly
Humidity	5...95% r.H.
Connections	ODF Copper
Vibration resistance	4g at 10...200Hz
Evaporating temperature	-35...+40°C
Package and delivery (individual)	without electrical connector

Electrical data

Stepper motor type	Bi-polar, phase current (constant current)
Electrical connection	4 pin terminal via plug
Supply Voltage	24 VDC (nominal)
Driver supply voltage range	18...36 VDC
Phase current, operating	FX5-9: 800 mA
Holding current	FX5/6/6.5: 500 mA FX7/7.5: 250 mA FX8/9: 500 mA

Total number of steps	FX5-7: 2400 full steps FX7.5: 2500 full steps FX8: 2600 full steps FX9: 3200 full steps
Step mode	Full step, half step or micro step
Stepping rate	330 Hz
Winding resistance per phase	3.4 Ohm ±10%
Reference position	Mechanical stop at fully close position
Full travel time	FX5-7: 7.3 sec. FX7.5: 7.6 sec. FX8: 7.9 sec. FX9: 9.7 sec.

Electronic Expansion Valves FX Series

Dimensions [mm]

Type	Part No.	A		B	C	D	E	F	G (Ø)	H
		A1	A2							
FX5-U07	801336	156	-	164	132	16	42	102	22 mm / 7/8" ODF	60
FX6-M28	801338	-	159	164	126	19	42	102	28 mm ODF	60
FX6-I09	801337	-	159	164	126	19	42	102	1-1/8" ODF	60
FX6.5-M28	801340	-	159	164	126	19	42	102	28 mm ODF	60
FX6.5-I09	801339	-	159	164	126	19	42	102	1-1/8" ODF	60
FX7-U11	801341	-	167	177	129	24	45	103	35 mm / 1-3/8" ODF	60
FX7.5-U11		191	-	177	129	24	67	104	35 mm / 1-3/8" ODF	60
FX8-M42		228	-	208	152	28	86	118	42 mm	60
FX8-I13		228	-	208	152	28	86	118	1-5/8" ODF	60
FX9-U17		-	270	189	C1: 86 C2: 35	34	116	125	54 mm / 2-1/8" ODF	60

FX5/FX6/FX6.5/FX7/FX7.5/FX8

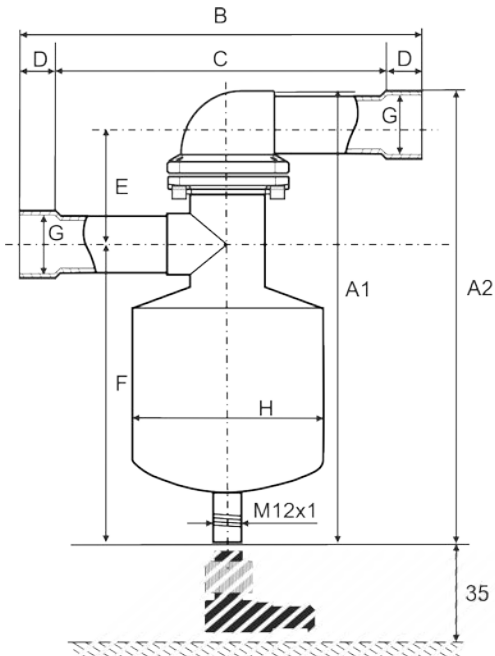

FX9

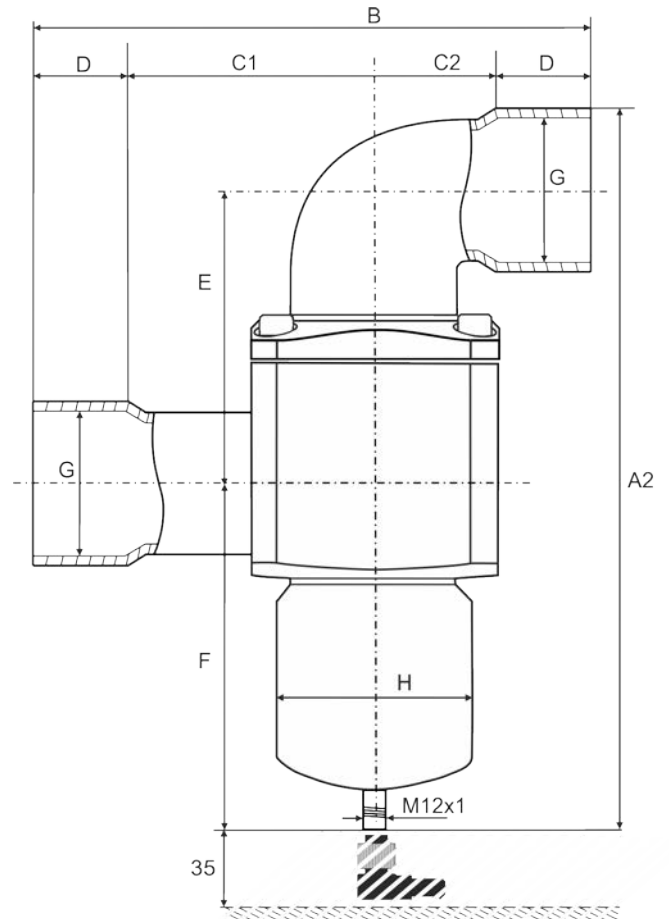

EC3-X32 / -X33 Superheat Controller with or without TCP/IP Communication Capability

EC3-X32/ -X33 are stand-alone universal superheat controllers for air conditioning, refrigeration and industrial applications such as chillers, industrial process cooling, rooftops, heat pumps, package unit, close control, cold room, food process and air driers.

EC3-X32 offers remote access with built-in TCP/IP Ethernet communications and WebServer functionality. Any standard WebBrowser can be used for monitoring or parameter setting.

EC3-X33 has no network communication.

Features

- Superheat control in conjunction with EMERSON stepper motor driven Electrical Control Valves EX4...EX8 and FX5...FX9
- Limitation of evaporating pressure (MOP)
- Low superheat alarm
- Feed through of 4...20 mA signal from evaporator pressure sensor to analogue output. This may also be connected to pressure input of any other controller to avoid need for multiple pressure sensors
- Monitoring of sensors and sensor wiring and detection of sensor and wiring failures
- Intelligent alarm management in order to protect the compressor i.e. fail safe operation
- Integral rechargeable battery to close Electrical Control Valve in case of power loss
- Electrical connection via plug-in type screw terminals
- Aluminum housing for DIN rail mounting

Additional Features EC3-X32 only

- High superheat alarm
- Low pressure switch function/alarm
- Freeze protection function/alarm
- Pump down function



EXD3-X32

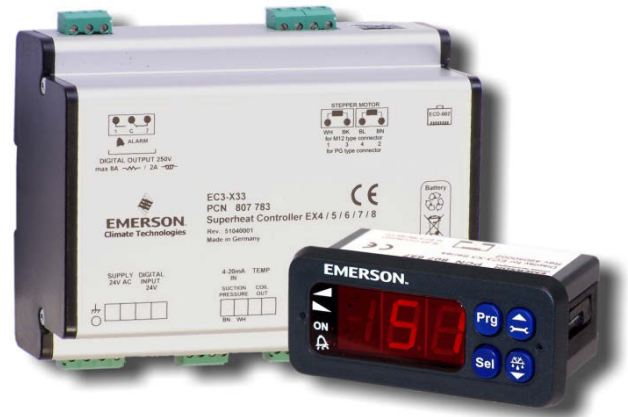

EC3-X33 with ECD-002

Selection Table - Controllers and Display Unit

Description	Type	Part No.
Superheat Controller	EC3-X33	807783
Terminal kit EC3-X33	K03-X33	807645
Superheat Controller	EC3-X32	807782
Terminal kit EC3-X32	K03-X32	807644
Display/keypad unit (opt.)	ECD-002	807657
Connection cable EC3 to ECD-002 (1.0m length)	ECC-N10	807860
Connection cable EC3 to ECD-002 (3.0m length)	ECC-N30	807861
Connection cable EC3 to ECD-002 (5.0m length)	ECC-N50	807862

Warning: R1234ze classified as A2L. Use of product only for non-explosive environment, non ATEX zone.

For further technical detail see Technical Bulletin.

EXD-SH1/2 Controller with ModBus Communication Capability

EXD-SH1/2 are stand-alone universal superheat and/or temperature controllers for air conditioning units or refrigeration systems.

Features

- EXD-SH1: Control of one valve
- EXD-SH2: Control of two valves in two independent circuits
- Main function:

	Circuit 1	Circuit 2
EXD-SH1	Superheat or temperature control	
EXD-SH2	Superheat or temperature control	Superheat Control
- Other functions: Limitation of evaporating pressure (MOP), Low pressure switch, freeze protection and manual positioning of valve(s)
- Self-adapting superheat control function in conjunction with EMERSON FX5-9, EX4-8 and CX4-7 series
- Modbus (RTU) communication
- Integrated keyboard with two lines display
- Monitoring of sensors and detection of sensor (ECN/PT5/6) / stepper motor wiring failures
- Optional upload/download key (accessory) for transmission of parameter settings among controllers with the same setting
- Low/high superheat alarm as well as other function alarms
- Electrical connection via plug-in type screw terminals included with controller and Micro Molex EXD-M05 (must be ordered separately)
- DIN rail mounting housing



EXD-SH2



EXD-M03

Selection table

Type	Description	Part No.	
		Multipack	Single pack
Controllers			
EXD-SH1	Controller for single refrigeration circuit	-	807855
EXD-SH2	Controller for two independent refrigeration circuits	-	807856
EXD-M03	Molex terminal with 3 meter wires	-	807865
ECN-N30	Temperature sensor with 3 meter cable	-	804496
ECN-N60	Temperature sensor with 6 meter cable	-	804497
ECN-Z60	Ultralow Temperature sensor with 6 meter cable	-	807826
Pressure transmitters: PT5/PT6 (7/16-20UNF connection)			
PT5-07M	Sensing pressure range -0.8 to 7 bar	802350M*	802350
PT5-18M	Sensing pressure range 0 to 18 bar	802351M*	802351
PT5-30M	Sensing pressure range 0 to 30 bar	802352M*	802352
PT5-50M	Sensing pressure range 0 to 50 bar	802353M*	802353
PT5-150D	Sensing pressure range 0 to 150 bar (1/4 NPTF)	-	802379
PT6-18M	Sensing pressure range 0 to 18 bar	802361M*	-
PT6-30M	Sensing pressure range 0 to 30 bar	802362M*	-
PT6-50M	Sensing pressure range 0 to 50 bar	802363M*	-
Pressure transmitters: PT5 (Brazing connection)			
PT5-07T	Sensing pressure range -0.8 to 7 bar	802380M**	802380
PT5-18T	Sensing pressure range 0 to 18 bar	802381M**	802381
PT5-30T	Sensing pressure range 0 to 30 bar	802382M**	802382
PT5-50T	Sensing pressure range 0 to 50 bar	802383M**	802383

Note: *) PT5-xxM Multipack = 20pcs, **) PT5-xxT Multipack = 10 pcs

⚠ Warning: R1234ze classified as A2L. Use of product only for non-explosive environment, non ATEX zone.

Accessories

Type	Description	Part No.	
		Multipack (20 pieces)	Single pack
M12 Plug and cable for pressure transmitters PT5/PT6			
PT4-M15	1.5 m	804803M	804803
PT4-M30	3.0 m	804804M	804804
PT4-M60	6.0 m	804805M	804805
Uninterruptible Power supply			
ECP-024	Backup battery with two outputs for two controllers	-	804558
K09-P00	Electrical Terminal Kit for ECP-024	-	804560
EXD-PM	Super cap for only EXD-SH1 (two pieces of EXD-PM required for one EXD-SH2)	-	807854

Superheat control of evaporators or economizers

This function requires the connection of temperature sensor(s) as well as pressure transmitters(s). The other functions are:

- MOP control: enables the limitation of saturated temperature of suction line (outlet of evaporator/economizer)
- Low pressure behaves similar to low pressure switch including alarm conditions
- Freeze protection is based on saturated temperature from converting measuring suction pressure. It provides alarm condition below certain adjusted temperature.

Temperature controller

The function is to maintain desired temperature by modulating refrigerant mass flow. If the controller is operated as temperature controller, the connection of pressure transmitter is not required.

In order to fulfill varieties of the applications, the refrigerant mass flow variation can be set according temperature increase or decrease.

**Temperature control in normal sense
(A: Mass flow increases if temperature rises)**

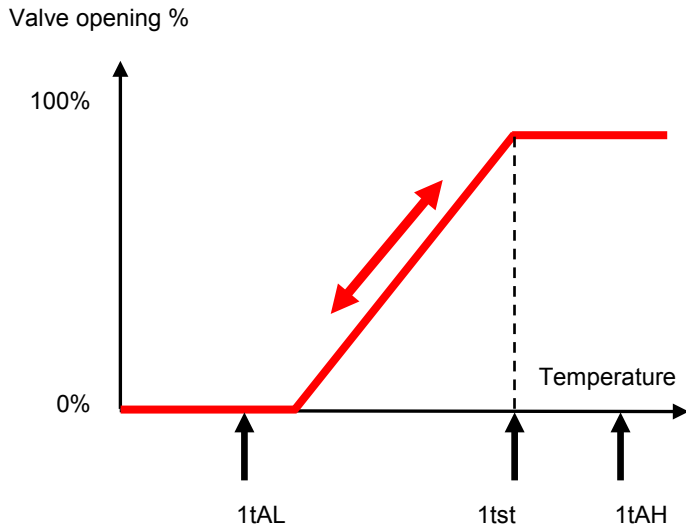

**Temperature control in reverse sense
(B: Mass flow decreases if temperature rises)**

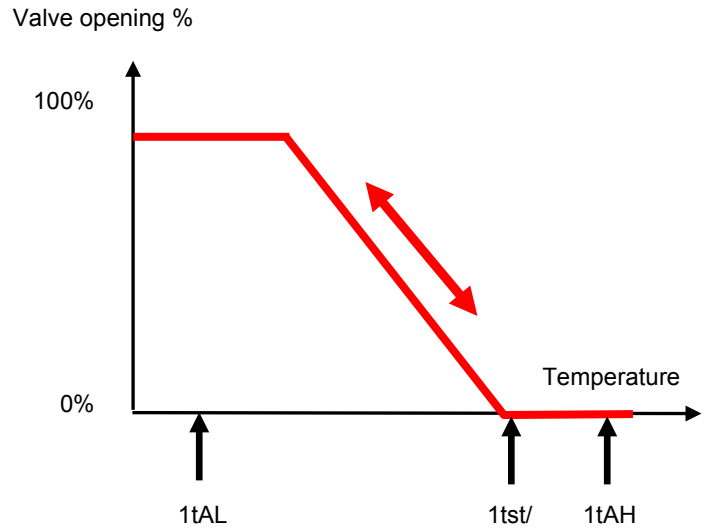

Examples of applications:

- Temperature control by throttling suction mass flow (normal sense, A)
- Temperature control by modulating hot gas into inlet or outlet of evaporators (reverse sense, B)
- Discharge temperature control by injecting liquid (normal sense, A)
- Head pressure control by means of temperature control (normal sense, A)

EXD-SH1/2 Controller with ModBus Communication Capability

Wiring

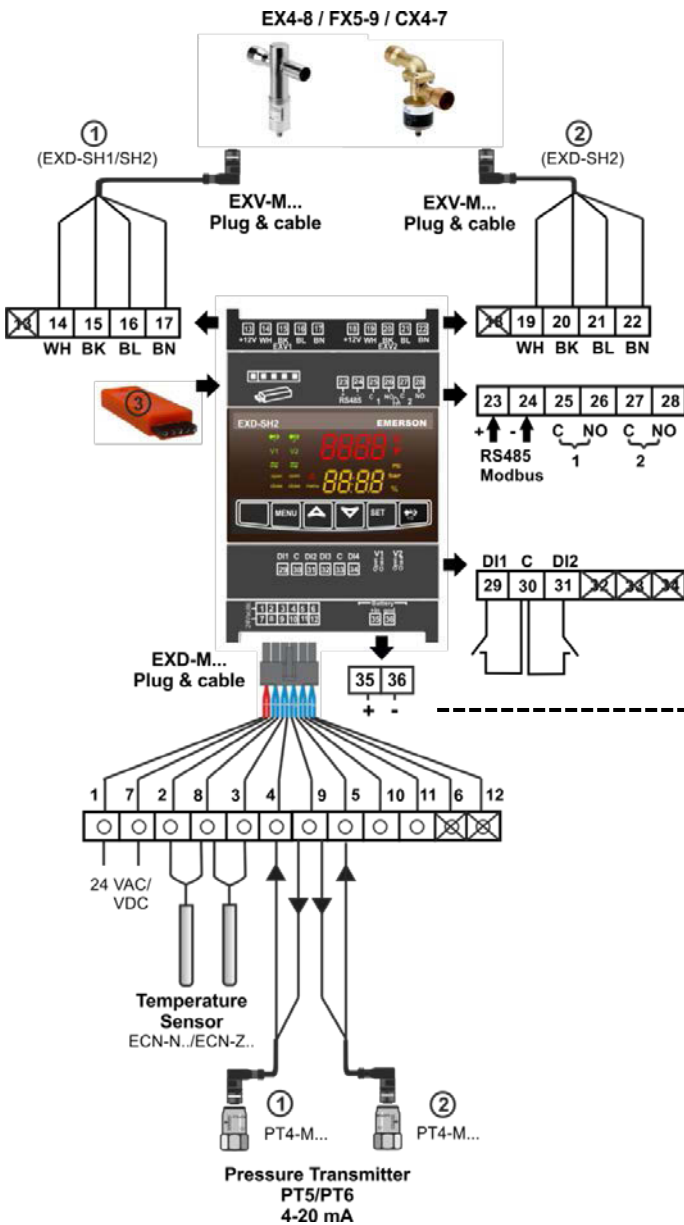

Wiring options: UPS (ECP-024) /Supercap (EXD-PM)

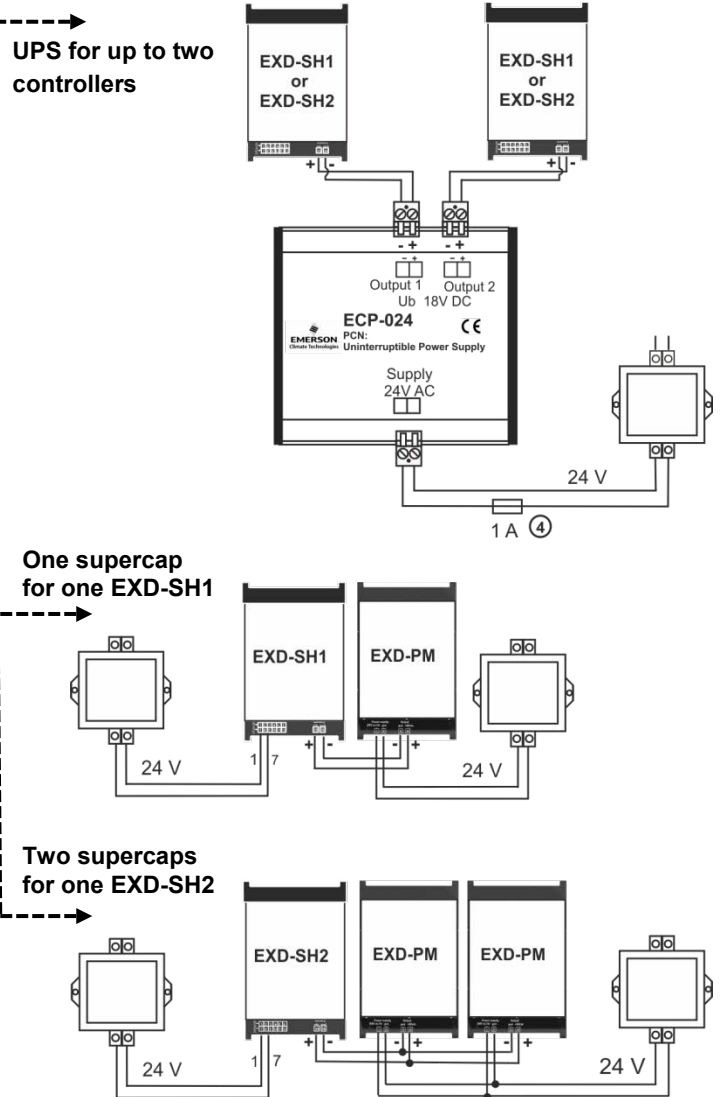

①	Circuit 1 (EXD-SH1/SH2)	14-17	Electronic expansion valve circuit 1 EXV-M... Electrical plug: wire colors
②	Circuit 2 (EXD-SH2)	19-22	Electronic expansion valve circuit 2 EXV-M... Electrical plug: wire colors WH-white BK-black BL-blue BN-brown
③	Download/upload key		
1 and 7	Supply voltage 24VAC/DC		
2 and 8	Temperature sensor circuit 1	23 and 24	RS485 (+/-terminal)
3 and 8	Temperature sensor circuit 2	25 and 26	Alarm relay circuit 1 (C, NO) – Suitable for 24VAC/DC
4 and 5	PT5/PT6 circuit 1 & circuit 2 (white wire: 4 to 20 mA signal)	27 and 28	Alarm relay circuit 2 (C, NO) – Suitable for 24VAC/DC
9	+ 12VDC Voltage input for PT5/PT6 (brown wire)	29 and 30	Digital input circuit1 (DI1) – Dry contact, potential free
Alternative ratiometric third Party Pressure Transmitter:			
4 and 5	Pressure transmitter circuit 1 & circuit 2 (0.5 to 4.5V signal)	31 and 30	Digital input circuit 2 (DI2) – Dry contact, potential free
11	+ 5VDC voltage input	35 and 36	Battery/Super capacitor connection terminal
10	GND Ground	④	Fuse
		6,12,13, 18,32-34	Not used (Terminals on EXD-SH12)

For further technical detail see Technical Bulletin.

Pressure Transmitter PT5

Features

- Thin-film stainless steel piezo sensor with output signal 4...20 mA and 2-wire connection for the precise operation of superheat, compressor or fan control systems
- Specially calibrated pressure ranges with $\pm 1\%$ accuracy performance to fulfill demands of today's refrigeration and HVAC applications
- Fully hermetic
- PT5-xxM with 7/16"-20UNF pressure connection and Schrader valve opener
- PT5-xxT with 6x40 mm stainless steel tube and integrated brazing neck for easy mounting in applications requiring a fully hermetic system solution
- Vibration, shock and pulsation resistant
- Protection class IP65 / IP67 (type-specific)



PT5-xxM with
PT4-Mxx Cable Assembly



PT5-07M



PT5-xx T

Selection table

Type	Part No.		Pressure range for signal output [bar]*	Output signal [mA]	Medium Temp. Range at pressure connection [°C]	Max. working pressure PS [bar]*	Test pressure PT [bar]*	Pressure Connection
	Single pack	Multi-pack**						
PT5-07M	802350	802350M	-0.8...7	4...20	-40...+100	27	30	7/16" – 20 UNF (with Schrader valve opener)
PT5-18M	802351	802351M	0...18			50	63	
PT5-30M	802352	802352M	0...30			60	100	
PT5-50M	802353	802353M	0...50			75	120	
PT5-07T	802380	802380M	-0.8...7			27	30	
PT5-18T	802381	802381M	0...18		50	63		
PT5-30T	802382	802382M	0...30		60	100		
PT5-50T	802383	802383M	0...50		75	120		

Note: *) Sealed gauge pressure **) PT5-xxM: 20 pcs, PT5-xxT: 10 pcs

⚠ Warning: R1234ze classified as A2L. Use of product only for non-explosive environment, non ATEX zone.

For further technical detail see Technical Bulletin.

Selection Plug/Cable Assemblies: assembly fits all models

Type	Part No.		Cable length [m]	Weight/pc [g]	Temperature Range [°C]
	Single pack	Multipack 20 pcs			
PT4-M15	804803	804803M	1.5	50	-50...+80°C static application -25...+80°C mobile application
PT4-M30	804804	804804M	3.0	80	
PT4-M60	804805	804805M	6.0	140	

Fan Speed Controls

FSE Fan Speed Control Module

Electronic Fan Speed Control Modules FSE generate a 0...10 V signal, which is used to control the speed of condenser fan motors in commercial refrigeration and air-conditioning systems. Ideal for use with high efficient EC-motors, but be also used with phase cut controllers for induction motors.

Features

- Energy saving due to improved cooling efficiency
- Pressure for minimum speed adjustable
- Small proportional band and large hysteresis to minimize cycling at small pressure changes
- Reduced fan noise level during low ambient temperature conditions
- Improved overall performance of cooling system
- Easy installation with cables for power supply and motor connection factory wired
- IP65 protection for outdoor mounting



FSE Control Module + PS3-Nxx

Standards:

- UL certification File No.: E355325

FSY Fan Speed Controller Series

Electronic Fan Speed Controllers FSY controls the speed of conventional type AC fan motors depending on pressure.

Features

- Pressure actuated fan speed control
- Adjustable pressure for cut-off
- High Voltage Triac (800 Volts)
- Integrated Protection circuit against voltage and current peaks
- Compact design
- Protection IP65
- Easy mounting and adjustment
- Easy retrofit in existing systems
- No additional gasket required (complete molded into plug)
- Multi-position Plug with EMC filter incl. 1.5 m (opt. 3 and 6 m) cable for flexible installation



FSY Controller + FSF-Nxx

Standards:

- **CE** per EC 89/336/EC (together with FSF cable)
- UL certification File No.: E183816

Selection table FSE

Type	Part No.	Refrigerants	Adjustment Range Z [bar]	Factory set point Z [bar]	P-Band [bar]	Hysteresis [bar]	Test Pressure [bar]	Weight [g]
FSE-01S	804701	R450A/R513A/R1234ze	4...12.5	~ 7.0	~ 2.3	~ 1.3	30 bar	125
FSE-02S	804706	R448A/R449A	10...21	~ 14.5	~ 3,6	~ 1.3	36 bar	125

Selection table FSY

Type	Part No.	Operational Current [A]	Pressure range [bar]	Factory setting [bar]	Max. operating Pressure PS [bar]	Test Pressure PT [bar]	Pressure connection
FSY-41S	0715533	0.1...4	4.0...12.5	8.0	27	30	7/16"-20 UNF female
FSY-42S	0715534		9.2...21.2	15	32	36	7/16"-20 UNF female

Cable Assemblies with Plug

Type	Part No.	Temperature Range [°C]	Cable length [m]
FSE	PS3-N15 804580	-25...+80°C	1.5
	PS3-N30 804581		3.0
	PS3-N60 804582		6.0
FSY	FSF-N15 804640	-50...+80°C	1.5
	FSF-N30 804641		3.0
	FSF-N60 804642		6.0

⚠ Warning: R1234ze classified as A2L. Use of product only for non-explosive environment, non ATEX zone.

For further technical detail see Technical Bulletin/ Datasheet.

Introduction

Superheat

The factory setting of a TI is made with the valve pin just starting to move away from the seat. The superheat increment necessary to get the pin ready to move is called static superheat (SS). An increase of superheat over and beyond the static superheat (factory setting) is necessary for the valve pin to open to its rated capacity. This additional superheat is known as gradient or opening superheat (OS).

The working superheat (WS), which can be measured in the field, is the sum of static superheat and opening superheat.

The opening superheat of TXV varies if the selected valve operates at higher or lower capacities than the rated capacity. It is highly recommended to select the valve according to the rated capacity. Using reserve capacity leads to larger opening superheat and longer pull down time during start-up or after defrost.

Selecting a larger valve than required in a system may lead to smaller opening superheat and/or hunting of TXV.

EMERSON Thermo®-Expansion Valves are factory pre-set for optimum superheat settings. This setting should be modified only if absolutely necessary. The readjustment should be at the **lowest** expected evaporating temperature.

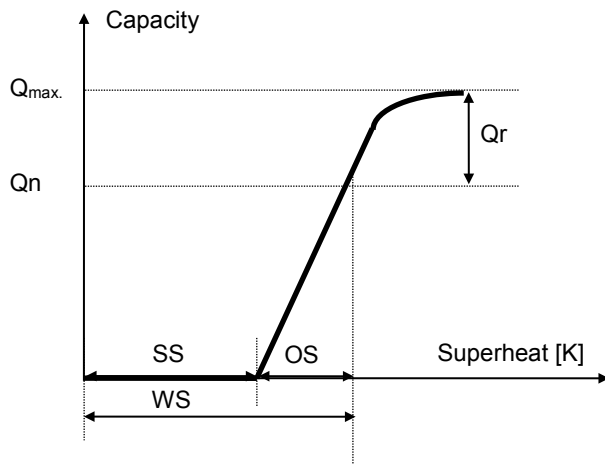

$Q_r = 0$ for TIO-00X and TIO-000
 $Q_r \approx 15\%$ of Q_n for all other orifices
 SS: Static superheat
 OS: Opening superheat
 WS: Working superheat

Subcooling

Subcooling generally increases the capacity of a refrigeration system and may be accounted for when dimensioning an expansion valve by applying the correction factor K_t . The capacity corrections for evaporating temperature, condensing temperature and subcooling are all incorporated in K_t . These are in particular the liquid density upstream from the expansion valve, the different enthalpies of liquid and vapour phase refrigerants as well as certain part of flash gas after expansion. The percentage of flash gas differs with various refrigerants and depends on system conditions.

MOP (Maximum Operating Pressure)

MOP functionality is somewhat similar to the application of a crankcase pressure regulator. Evaporator pressures are limited to a maximum value to protect the compressor from overload conditions.

MOP selection should be within maximum allowed suction pressure rating of the compressor and at approximately 3 K above maximum evaporating temperature.

Performance of TXV with MOP function with gas charge

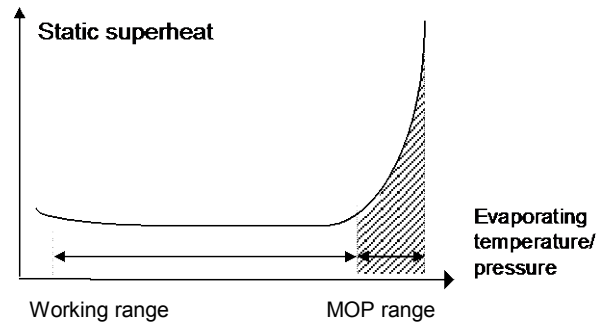

Valve operates as superheat control in normal working range and operates as pressure regulator within MOP range.

Cross ambient

The cross ambient effect occurs on TXV with a gas charge when the temperature at the bulb is higher than temperature at the valve head. The construction of TXV with interchangeable orifice from liquid inlet connection leads that the warmer liquid enters into the bottom of valve and cold refrigerant leaves the valve near the valve head. Therefore the valve head becomes cold.

The chance of cross ambient effect is very great if the total superheat is/becomes large. In many applications gas charges are not suitable for the valve with interchangeable orifice construction unless the valve head is wrapped by an electric strip heater. The adsorption charge with similar MOP function is another solution.

Heavy subcooling results in very small flash gas amounts and therefore **increases expansion valve capacities**. These conditions are not covered. Likewise, small flash gas amounts lead to reduced evaporator capacities and may result in substantial discrepancies between the capacities of the Thermo®-Expansion Valve and the evaporator. These effects must be considered during component selection when designing refrigeration circuits.

Quick selection tables are for very small amount of subcooling. For larger subcooling than 5K, please use Controls navigator selection program.

TI Series - Thermo™-Expansion Valves

EMERSON TI series of Thermo™-Expansion Valves with interchangeable orifices are designed for refrigeration applications such as display cases in supermarkets, walk-in/reach-in coolers, freezers, soft ice cream/ice maker machines, milk tank coolers, transport refrigeration as well as for air conditioning and heat pump systems. TI provides flexibility in selection of capacity and is ideal for those applications requiring compact size with stable and accurate control over wide load and evaporating range.

Features

- Eight interchangeable orifice assemblies provide a capacity range from 0.5...19.4 kW based on R448A
- 45 bar maximum working pressure allows the use of high pressure refrigerants
- Three styles of connections:
 - TILE: Stainless steel brazed fittings eliminate the need of wet rags during brazing
 - TIS(E): Copper brazed fittings (valve requires wet rag during brazing)
 - TI(E): Flare
- Cleanable / exchangeable inlet strainer in orifice assembly
- Constant superheat across a wide application range
- Large diaphragm eliminates disturbances to the valve and provides smoother and consistent valve control
- Laser welded stainless steel power element
- Internal or external equalizer
- Inlet brazing adapter
- Adjustable static superheat
- Special setting upon request an minimum 100 pieces order quantity



TISE



TIE



TILE

Selection table: Orifice assembly (with strainer)

Orifice type	Part No.	Nominal capacity [kW]				
		R448A	R449A	R450A	R513A	R1234ze
TIO-00X	800532	0.50	0.49	0.20	0.21	0.23
TIO-000	800533	1.30	1.27	0.55	0.56	0.63
TIO-001	800534	3.19	3.12	1.30	1.33	1.49
TIO-002	800535	5.28	5.16	2.11	2.16	2.42
TIO-003	800536	8.48	8.28	3.41	3.49	3.91
TIO-004	800537	13.86	13.54	5.66	5.79	6.49
TIO-005	800538	16.85	16.46	6.89	7.05	7.90
TIO-006	800539	19.44	19.00	7.98	8.17	9.15

Note: Products are classified based on fluid group 2 (non-flammable) according European pressure equipment directive.

For selection of other operating condition, please use TI quick selection tables in the next pages or Controls Navigator selection program.

The nominal capacity is based on the following conditions:

Refrigerant	Evaporating temperature [°C]	Condensing temperature [°C]	Subcooling
R513A, R1234ze	+4°C dew point	+38°C bubble/ +38°C dew point	1K
R450A		+38°C bubble/ +38.6°C dew point	
R448A, R449A		+38°C bubble/ +42.6°C dew point	

TI Series - Thermo™-Expansion Valves

Selection table: Valve bodies without orifice and nuts in single packaging

Refrigerant	Connection	Valves with factory setting and/or new charges					Valve for field setting	
		Type	Part No.	Equalizer	Charge	MOP	Type	Part No.
R448A/ R449A	Braze stainless steel fittings *	TILE-BW (12 mm)		External	Liquid	No	TILE-SW (12 mm)	802465
		TILE-BW (1/2")			Liquid	No	TILE-SW (1/2")	802466
	Braze copper fittings **	TISE-BW (12 mm)			Liquid	No	TISE-SW (12 mm)	802462
		TISE-BW (1/2")			Liquid	No	TISE-SW (1/2")	802464
		TISE-BW30 (1/2")			Vapor	Yes		-
		TISE-BW70 (1/2")			Vapor	Yes	TISE-SW75 (1/2")	802472
		TIS-BW (12 mm)		Internal	Liquid	No	TIS-SW (12 mm)	802461
	TIS-BW (1/2")		Liquid		No	TIS-SW (1/2")	802463	
	Flare fittings	TIE-BW		External	Liquid	No	TIE-SW	802460
		TIE-BW70			Vapor	Yes	TIE-SW75	802470
		TI-BW		Internal	Liquid	No	TI-SW	802459
	R450A	Braze stainless steel fittings *	TILE-DW (12 mm)		External	Liquid	No	TILE-MW (12 mm)
TILE-DW (1/2")				Liquid		No	TILE-MW (1/2")	802452
Braze copper fittings **		TISE-DW (12 mm)		Liquid		No	TISE-MW (12 mm)	802448
		TISE-DW (1/2")		Liquid		No	TISE-MW (1/2")	802450
		TISE-DW55 (12 mm)		Vapor		Yes	TISE-MW55 (12 mm)	802457
		TISE-DW55 (1/2")		Vapor		Yes	TISE-MW55 (1/2")	802458
		TIS-DW (12 mm)		Internal	Liquid	No	TIS-MW (12 mm)	802447
TIS-DW (1/2")			Liquid		No	TIS-MW (1/2")	802449	
Flare fittings		TIE-DW		External	Liquid	No	TIE-MW	802446
		TI-DW		Internal	Liquid	No	TI-MW	802445
R513A	Braze stainless steel fittings *	TILE-CW (12 mm)		External	Liquid	No	TILE-MW (12 mm)	802451
		TILE-CW (1/2")			Liquid	No	TILE-MW (1/2")	802452
	Braze copper fittings **	TISE-CW (12 mm)			Liquid	No	TISE-MW (12 mm)	802448
		TISE-CW (1/2")			Liquid	No	TISE-MW (1/2")	802450
		TISE-CW55 (12 mm)			Vapor	Yes	TISE-MW55 (12 mm)	802457
		TISE-CW55 (1/2")			Vapor	Yes	TISE-MW55 (1/2")	802458
		TIS-CW (12 mm)		Internal	Liquid	No	TIS-MW (12 mm)	802447
	TIS-CW (1/2")		Liquid		No	TIS-MW (1/2")	802449	
	Flare fittings	TIE-CW		External	Liquid	No	TIE-MW	802446
		TI-CW		Internal	Liquid	No	TI-MW	802445
R1234ze	Braze copper fittings **	TISE-EW (12 mm)		External	Liquid	No	TISE-MW (12 mm)	802448
		TISE-EW (1/2")			Liquid	No	TISE-MW (1/2")	802450
		TISE-EW55 (12 mm)			Vapor	Yes	TISE-MW55 (12 mm)	802457
		TISE-EW55 (1/2")			Vapor	Yes	TISE-MW55 (1/2")	802458
		TIS-EW (12 mm)			Liquid	No	TIS-MW (12 mm)	802447
		TIS-EW (1/2")			Liquid	No	TIS-MW (1/2")	802449
	Flare fittings	TIE-EW		Internal	Liquid	No	TIE-MW	802446
		TI-EW			Liquid	No	TI-MW	802445

Note: Please see table on the next page for readjustment in order to be used with HFO/HFO blends.

*) TILE Braze without wet rag

***) TISE Braze with wet rag

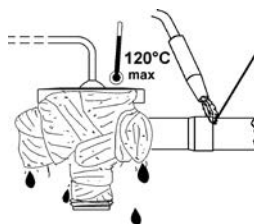
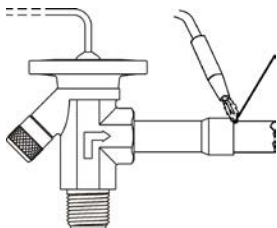

TI Series - Thermo™-Expansion Valves

Connections

Body	Inlet connection		Outlet	External equalizer *
	Brazing with adapter	Flare		
TI(E) Flare connections	-	5/8"-18UNF Flare suitable for 6 mm, 8 mm, 10 mm, 1/4", 5/16", 3/8" tubes	3/4"-16UNF Flare: for 12 mm, 1/2" tubes	7/16"-20UNF Flare: for 6 mm, 1/4" tubes
TIS(E) / TILE Brazing connections	TIA-M06 (6 mm ODF) TIA-M10 (10 mm ODF)		12 mm ODF	6 mm ODF
	TIA-014 (1/4" ODF) TIA-038 (3/8" ODF)	1/2" ODF	1/4" ODF	

Note: *) TI and TIS with internal equalizer

MOP value, gas charge

Code	MOP [bar]
MW55	3.8
SW75	5.2
BW30	1.6
BW70	4.3



Accessories

Description	Type	Part No.	Connection size
Brazing adapter	TIA-M06	802500	6 mm
	TIA-M10	802501	10 mm
	TIA-014	802502	1/4"
	TIA-038	802503	3/8"

The following table/graphic is a guideline for readjustment:

Evaporating temperature [°C]	Number of turn			
	TI...-MW...		TI...-SW...	
	System refrigerant			
	R450A	R513A	R1234ze	R448A R449A
-40	1/3	-1/3	2/3	1-2/3
-35	1/2	-1/2	1	2
-30	2/3	-1/2	1	2-1/4
-25	3/4	-2/3	1-1/3	2-1/2
-20	1	-2/3	1-3/4	3
-15	1-1/4	-1	2-1/3	3-1/2
-10	1-1/2	-1	2-1/2	3-3/4
-5	1-2/3	-1-1/4	3-1/3	4-1/4
0	2	-1-1/3	3-1/2	4-3/4
5	2-1/3	-1,5	4-1/2	5
10	2-2/3	-1-2/3	5-1/4	5-2/3

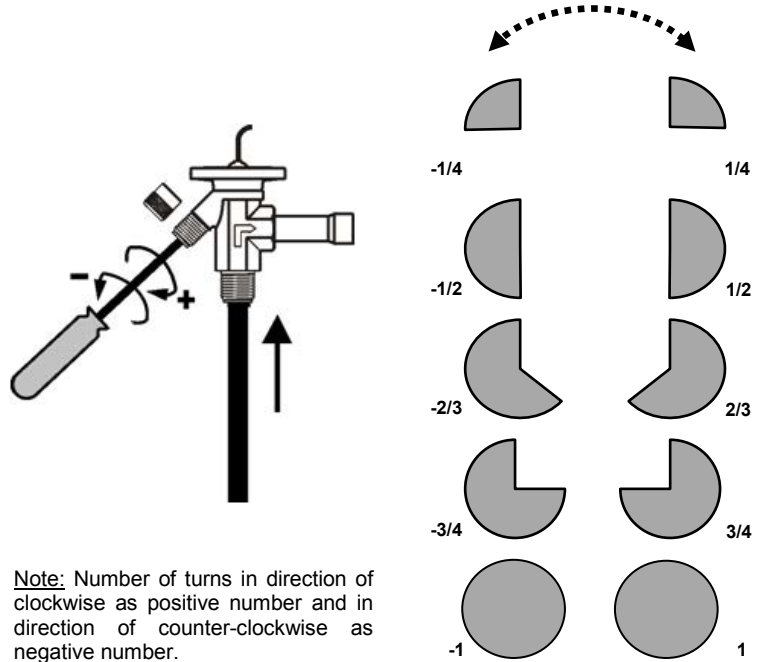

Note: Number of turns in direction of clockwise as positive number and in direction of counter-clockwise as negative number.

TI Series - Thermo™-Expansion Valves

TI: Quick selection (included 1.5 bar pressure drop for liquid line components and distributor)

Condensing temperature [°C]	R448A/R449A													Orifice type
	Capacity [kW]													
	Evaporating temperature [°C]													
	15	10	5	0	-5	-10	-15	-20	-25	-30	-35	-40	-45	
60 bubble/ 63.4 dew point	0.46	0.46	0.46	0.46	0.46	0.45	0.40	0.34	0.28	0.23	0.18	0.15	0.12	TIO-00x
	1.18	1.20	1.20	1.20	1.19	1.18	1.04	0.88	0.72	0.59	0.47	0.38	0.31	TIO-000
	2.9	2.9	3.0	3.0	2.9	2.9	2.6	2.2	1.8	1.44	1.16	0.94	0.76	TIO-001
	4.8	4.9	4.9	4.9	4.9	4.8	4.3	3.6	3.0	2.4	1.9	1.6	1.3	TIO-002
	7.7	7.8	7.9	7.8	7.8	7.7	6.8	5.8	4.7	3.8	3.1	2.5	2.0	TIO-003
	12.7	12.8	12.8	12.8	12.8	12.6	11.2	9.4	7.7	6.3	5.0	4.1	3.3	TIO-004
	15.4	15.5	15.6	15.6	15.5	15.3	13.6	11.5	9.4	7.6	6.1	4.9	4.0	TIO-005
17.8	17.9	18.0	18.0	17.9	17.7	15.7	13.2	10.9	8.8	7.1	5.7	4.6	TIO-006	
50 bubble/ 54 dew point	0.46	0.47	0.48	0.49	0.49	0.49	0.43	0.37	0.31	0.25	0.20	0.16	0.13	TIO-00x
	1.20	1.23	1.25	1.27	1.27	1.27	1.13	0.96	0.80	0.65	0.53	0.43	0.35	TIO-000
	3.0	3.0	3.1	3.1	3.1	3.1	2.8	2.4	2.0	1.60	1.30	1.05	0.86	TIO-001
	4.9	5.0	5.1	5.2	5.2	5.2	4.6	3.9	3.2	2.6	2.1	1.7	1.4	TIO-002
	7.9	8.1	8.2	8.3	8.3	8.3	7.4	6.3	5.2	4.2	3.4	2.8	2.3	TIO-003
	12.9	13.2	13.4	13.5	13.6	13.6	12.1	10.3	8.5	6.9	5.6	4.6	3.7	TIO-004
	15.6	16.0	16.3	16.5	16.5	16.5	14.7	12.5	10.3	8.4	6.8	5.6	4.5	TIO-005
18.0	18.5	18.8	19.0	19.1	19.0	17.0	14.4	11.9	9.7	7.9	6.4	5.2	TIO-006	
40 bubble/ 44.5 dew point	0.43	0.45	0.47	0.48	0.49	0.49	0.44	0.38	0.32	0.26	0.21	0.17	0.14	TIO-00x
	1.12	1.18	1.22	1.25	1.27	1.28	1.15	0.99	0.82	0.67	0.55	0.45	0.37	TIO-000
	2.8	2.9	3.0	3.1	3.1	3.2	2.8	2.4	2.0	1.66	1.36	1.11	0.91	TIO-001
	4.6	4.8	5.0	5.1	5.2	5.2	4.7	4.0	3.4	2.7	2.2	1.8	1.5	TIO-002
	7.3	7.7	8.0	8.2	8.3	8.4	7.5	6.5	5.4	4.4	3.6	2.9	2.4	TIO-003
	12.0	12.6	13.1	13.4	13.6	13.7	12.3	10.6	8.8	7.2	5.9	4.8	4.0	TIO-004
	14.6	15.3	15.9	16.2	16.5	16.6	15.0	12.8	10.7	8.8	7.2	5.9	4.8	TIO-005
16.9	17.7	18.3	18.7	19.0	19.2	17.3	14.8	12.3	10.1	8.3	6.8	5.5	TIO-006	
30 bubble/ 34.5 dew point	0.36	0.40	0.42	0.45	0.46	0.47	0.43	0.37	0.31	0.26	0.21	0.17	0.14	TIO-00x
	0.94	1.03	1.10	1.16	1.20	1.22	1.11	0.96	0.81	0.67	0.55	0.45	0.37	TIO-000
	2.3	2.5	2.7	2.9	2.9	3.0	2.7	2.4	2.0	1.65	1.35	1.11	0.92	TIO-001
	3.8	4.2	4.5	4.7	4.9	5.0	4.5	3.9	3.3	2.7	2.2	1.8	1.5	TIO-002
	6.1	6.8	7.2	7.6	7.8	8.0	7.3	6.3	5.3	4.4	3.6	3.0	2.4	TIO-003
	10.0	11.0	11.8	12.4	12.8	13.1	11.9	10.3	8.7	7.2	5.9	4.8	4.0	TIO-004
	12.2	13.4	14.4	15.1	15.6	15.9	14.5	12.5	10.5	8.7	7.1	5.9	4.9	TIO-005
14.0	15.5	16.6	17.4	18.0	18.4	16.7	14.5	12.1	10.0	8.2	6.8	5.6	TIO-006	
20 bubble/ 25.3 dew point	0.29	0.34	0.38	0.40	0.42	0.39	0.35	0.29	0.24	0.20	0.17	0.14	TIO-00x	
	0.76	0.89	0.98	1.05	1.10	1.02	0.90	0.76	0.64	0.53	0.44	0.36	TIO-000	
	1.9	2.2	2.4	2.6	2.7	2.5	2.2	1.9	1.56	1.29	1.07	0.89	TIO-001	
	3.1	3.6	4.0	4.3	4.5	4.2	3.7	3.1	2.6	2.1	1.8	1.5	TIO-002	
	5.0	5.8	6.4	6.9	7.2	6.7	5.9	5.0	4.2	3.4	2.8	2.4	TIO-003	
	8.1	9.5	10.5	11.2	11.8	10.9	9.6	8.1	6.8	5.6	4.7	3.9	TIO-004	
	9.9	11.5	12.8	13.7	14.3	13.3	11.7	9.9	8.3	6.8	5.7	4.7	TIO-005	
11.4	13.3	14.7	15.8	16.5	15.3	13.5	11.4	9.5	7.9	6.5	5.4	TIO-006		
10 bubble/ 15.5 dew point	0.26	0.31	0.35	0.33	0.30	0.26	0.22	0.18	0.15	0.13	TIO-00x			
	0.68	0.81	0.90	0.87	0.78	0.68	0.57	0.48	0.40	0.34	TIO-000			
	1.7	2.0	2.2	2.1	1.9	1.7	1.41	1.18	0.99	0.83	TIO-001			
	2.8	3.3	3.7	3.5	3.2	2.8	2.3	2.0	1.6	1.4	TIO-002			
	4.4	5.3	5.9	5.7	5.1	4.4	3.8	3.1	2.6	2.2	TIO-003			
	7.3	8.7	9.6	9.3	8.4	7.3	6.1	5.1	4.3	3.6	TIO-004			
	8.8	10.5	11.7	11.3	10.2	8.8	7.5	6.2	5.2	4.4	TIO-005			
10.2	12.1	13.5	13.0	11.7	10.2	8.6	7.2	6.0	5.0	TIO-006				

TI Series - Thermo™-Expansion Valves

TI: Quick selection (included 1.5 bar pressure drop for liquid line components and distributor)

Condensing temperature [°C]	R450A/R513A											Orifice type	
	Capacity [kW]												
	Evaporating temperature [°C]												
	20	15	10	5	0	-5	-10	-15	-20	-25	-30		
60	0,20	0,20	0,20	0,20	0,20	0,20	0,20	0,17	0,14	0,11	0,09	TIO-00x	
	0,53	0,54	0,54	0,54	0,54	0,54	0,53	0,52	0,47	0,39	0,31	0,24	TIO-000
	1,3	1,3	1,3	1,3	1,3	1,3	1,3	1,2	1,1	0,9	0,7	0,57	TIO-001
	2,1	2,1	2,1	2,1	2,1	2,1	2,1	2,0	1,8	1,5	1,2	0,9	TIO-002
	3,3	3,4	3,4	3,4	3,4	3,4	3,3	3,3	2,9	2,4	1,9	1,5	TIO-003
	5,5	5,6	5,6	5,6	5,6	5,6	5,5	5,4	4,8	4,0	3,2	2,5	TIO-004
	6,7	6,8	6,9	6,9	6,8	6,7	6,7	6,6	5,9	4,9	3,9	3,0	TIO-005
7,8	7,9	8,0	7,9	7,9	7,9	7,8	7,7	6,8	5,6	4,5	3,5	TIO-006	
50	0,18	0,19	0,19	0,20	0,20	0,20	0,20	0,18	0,15	0,12	0,09	TIO-00x	
	0,48	0,51	0,52	0,53	0,53	0,53	0,53	0,47	0,40	0,32	0,25	TIO-000	
	1,2	1,2	1,2	1,3	1,3	1,3	1,3	1,1	0,9	0,8	0,59	TIO-001	
	1,9	2,0	2,0	2,0	2,1	2,1	2,0	1,8	1,5	1,2	1,0	TIO-002	
	3,0	3,2	3,2	3,3	3,3	3,3	3,3	3,0	2,5	2,0	1,6	TIO-003	
	5,0	5,2	5,4	5,5	5,5	5,5	5,5	4,9	4,1	3,3	2,6	TIO-004	
	6,1	6,4	6,6	6,7	6,7	6,7	6,7	6,0	5,0	4,0	3,1	TIO-005	
7,1	7,4	7,6	7,7	7,8	7,8	7,7	6,9	5,8	4,6	3,6	TIO-006		
40	0,14	0,16	0,17	0,18	0,18	0,19	0,19	0,17	0,14	0,12	0,09	TIO-00x	
	0,38	0,43	0,46	0,48	0,49	0,50	0,50	0,46	0,39	0,31	0,25	TIO-000	
	0,9	1,0	1,1	1,1	1,2	1,2	1,2	1,1	0,9	0,7	0,59	TIO-001	
	1,5	1,7	1,8	1,9	1,9	1,9	2,0	1,8	1,5	1,2	1,0	TIO-002	
	2,4	2,7	2,9	3,0	3,1	3,1	3,2	2,9	2,4	2,0	1,5	TIO-003	
	4,0	4,4	4,7	5,0	5,1	5,2	5,2	4,8	4,0	3,2	2,6	TIO-004	
	4,9	5,4	5,8	6,0	6,2	6,3	6,4	5,8	4,9	3,9	3,1	TIO-005	
5,6	6,2	6,7	7,0	7,2	7,3	7,4	6,7	5,7	4,6	3,6	TIO-006		
30	0,06	0,10	0,13	0,14	0,16	0,16	0,17	0,16	0,13	0,11	0,09	TIO-00x	
	0,16	0,28	0,34	0,38	0,42	0,44	0,45	0,42	0,36	0,29	0,23	TIO-000	
	0,4	0,7	0,8	0,9	1,0	1,0	1,1	1,0	0,8	0,7	0,55	TIO-001	
	0,6	1,1	1,3	1,5	1,6	1,7	1,7	1,6	1,4	1,1	0,9	TIO-002	
	1,0	1,7	2,1	2,4	2,6	2,7	2,8	2,6	2,2	1,8	1,5	TIO-003	
	1,7	2,9	3,5	4,0	4,3	4,5	4,7	4,3	3,7	3,0	2,4	TIO-004	
	2,0	3,5	4,3	4,9	5,2	5,5	5,7	5,3	4,5	3,7	2,9	TIO-005	
2,4	4,0	5,0	5,6	6,1	6,4	6,6	6,1	5,2	4,3	3,4	TIO-006		
20				0,08	0,11	0,12	0,13	0,13	0,11	0,10	0,08	TIO-00x	
				0,21	0,28	0,33	0,36	0,35	0,30	0,25	0,21	TIO-000	
				0,5	0,7	0,8	0,9	0,8	0,7	0,6	0,49	TIO-001	
				0,8	1,1	1,3	1,4	1,3	1,2	1,0	0,8	TIO-002	
				1,3	1,8	2,0	2,2	2,2	1,9	1,6	1,3	TIO-003	
				2,1	2,9	3,4	3,7	3,6	3,2	2,6	2,1	TIO-004	
				2,6	3,5	4,1	4,5	4,4	3,8	3,2	2,6	TIO-005	
			3,0	4,1	4,8	5,3	5,1	4,5	3,7	3,0	TIO-006		
10						0,03	0,07	0,09	0,08	0,07	0,06	TIO-00x	
						0,08	0,19	0,23	0,22	0,19	0,16	TIO-000	
						0,2	0,5	0,5	0,5	0,5	0,39	TIO-001	
						0,3	0,8	0,9	0,9	0,8	0,6	TIO-002	
						0,5	1,2	1,4	1,4	1,2	1,0	TIO-003	
						0,8	2,0	2,4	2,3	2,0	1,7	TIO-004	
						1,0	2,5	2,9	2,8	2,5	2,1	TIO-005	
					1,2	2,9	3,3	3,2	2,8	2,4	TIO-006		

TI Series - Thermo™-Expansion Valves

TI: Quick selection (included 1.5 bar pressure drop for liquid line components and distributor)

Condensing temperature [°C]	R1234ze											Orifice type	
	Capacity [kW]												
	Evaporating temperature [°C]												
	20	15	10	5	0	-5	-10	-15	-20	-25	-30		
60	0,23	0,23	0,23	0,23	0,23	0,23	0,22	0,20	0,16	0,13	0,10	TIO-00x	
	0,61	0,62	0,62	0,62	0,62	0,62	0,61	0,59	0,53	0,44	0,34	0,27	TIO-000
	1,5	1,5	1,5	1,5	1,5	1,5	1,4	1,4	1,3	1,0	0,8	0,63	TIO-001
	2,4	2,4	2,4	2,4	2,4	2,4	2,4	2,3	2,0	1,7	1,3	1,0	TIO-002
	3,8	3,9	3,9	3,9	3,8	3,8	3,8	3,7	3,3	2,7	2,2	1,7	TIO-003
	6,3	6,4	6,5	6,4	6,4	6,3	6,2	5,5	4,5	3,6	2,8	2,8	TIO-004
	7,7	7,8	7,9	7,8	7,8	7,7	7,5	6,7	5,5	4,4	3,4	3,4	TIO-005
	8,9	9,1	9,1	9,1	9,0	8,9	8,7	7,7	6,4	5,0	3,9	3,9	TIO-006
50	0,20	0,21	0,22	0,22	0,23	0,22	0,22	0,20	0,17	0,13	0,10	TIO-00x	
	0,55	0,57	0,59	0,60	0,60	0,60	0,60	0,53	0,45	0,36	0,28	TIO-000	
	1,3	1,4	1,4	1,4	1,4	1,4	1,4	1,3	1,1	0,8	0,66	TIO-001	
	2,1	2,2	2,3	2,3	2,3	2,3	2,3	2,1	1,7	1,4	1,1	TIO-002	
	3,4	3,6	3,7	3,7	3,8	3,7	3,7	3,3	2,8	2,2	1,7	TIO-003	
	5,7	5,9	6,1	6,2	6,2	6,2	6,2	5,5	4,6	3,7	2,9	TIO-004	
	6,9	7,2	7,4	7,5	7,6	7,6	7,5	6,7	5,6	4,5	3,5	TIO-005	
	8,0	8,4	8,6	8,7	8,8	8,8	8,7	7,8	6,5	5,2	4,1	TIO-006	
40	0,16	0,18	0,19	0,20	0,21	0,21	0,21	0,19	0,16	0,13	0,10	TIO-00x	
	0,41	0,47	0,51	0,53	0,55	0,56	0,56	0,51	0,43	0,35	0,27	TIO-000	
	1,0	1,1	1,2	1,3	1,3	1,3	1,3	1,2	1,0	0,8	0,65	TIO-001	
	1,6	1,8	2,0	2,1	2,1	2,2	2,2	2,0	1,7	1,3	1,1	TIO-002	
	2,6	2,9	3,2	3,3	3,4	3,5	3,5	3,2	2,7	2,2	1,7	TIO-003	
	4,3	4,9	5,2	5,5	5,7	5,8	5,8	5,3	4,5	3,6	2,8	TIO-004	
	5,2	5,9	6,4	6,7	6,9	7,0	7,1	6,5	5,5	4,4	3,5	TIO-005	
	6,1	6,9	7,4	7,8	8,0	8,2	8,2	7,5	6,3	5,1	4,0	TIO-006	
30	0,01	0,10	0,13	0,15	0,17	0,18	0,19	0,17	0,15	0,12	0,10	TIO-00x	
	0,03	0,26	0,35	0,41	0,45	0,48	0,49	0,46	0,39	0,32	0,26	TIO-000	
	0,1	0,6	0,8	1,0	1,1	1,1	1,2	1,1	0,9	0,8	0,61	TIO-001	
	0,1	1,0	1,4	1,6	1,7	1,8	1,9	1,8	1,5	1,2	1,0	TIO-002	
	0,2	1,7	2,2	2,6	2,8	3,0	3,1	2,9	2,5	2,0	1,6	TIO-003	
	0,3	2,7	3,7	4,3	4,7	4,9	5,1	4,8	4,1	3,3	2,7	TIO-004	
	0,3	3,3	4,5	5,2	5,7	6,0	6,2	5,8	5,0	4,1	3,2	TIO-005	
	0,4	3,9	5,2	6,0	6,6	7,0	7,2	6,7	5,8	4,7	3,7	TIO-006	
20				0,06	0,10	0,12	0,14	0,14	0,12	0,10	0,08	TIO-00x	
				0,15	0,27	0,33	0,38	0,37	0,33	0,27	0,22	TIO-000	
				0,4	0,6	0,8	0,9	0,9	0,8	0,6	0,53	TIO-001	
				0,6	1,0	1,3	1,5	1,4	1,3	1,1	0,9	TIO-002	
				0,9	1,7	2,1	2,3	2,3	2,0	1,7	1,4	TIO-003	
				1,5	2,8	3,5	3,9	3,8	3,4	2,8	2,3	TIO-004	
				1,9	3,4	4,2	4,7	4,6	4,1	3,4	2,8	TIO-005	
				2,2	3,9	4,9	5,5	5,4	4,8	4,0	3,2	TIO-006	
10							0,05	0,08	0,08	0,07	0,06	TIO-00x	
							0,12	0,20	0,21	0,19	0,17	TIO-000	
							0,3	0,5	0,5	0,5	0,39	TIO-001	
							0,5	0,8	0,8	0,8	0,6	TIO-002	
							0,8	1,3	1,3	1,2	1,0	TIO-003	
							1,3	2,1	2,2	2,0	1,7	TIO-004	
							1,5	2,5	2,7	2,4	2,1	TIO-005	
							1,8	2,9	3,1	2,8	2,4	TIO-006	

Note: Products are classified based on fluid group 2 (non-flammable) according European pressure equipment directive.

Thermo™-Expansion Valves T-, L-, 935-, ZZ-Series

EMERSON Take-apart Thermo™-Expansion Valves are designed for air conditioning, chillers, rooftops, close control, A/C transportation, heat pumps, industrial cooling process, refrigeration and numerous special applications. The take-apart expansion valves are ideal for those applications requiring flexibility in selection of capacity and excellent stable superheat control under varying operating conditions such as high and low head pressure, wide load variation and partial load down to 10%. Valves with XB power elements can be applied in systems with Copeland Digital Scroll™ Compressors.

Features

- Take-apart design consists of power element, cage and flange
- Large diaphragm eliminates disturbances to the valve and provides smoother and consistent valve control over wide range of operation
- Constant superheat across a wide application range
- ZZ-Series: expansion valves for evaporating temperature down to -100°C
- L / 935-Series: desuperheating of two stage compressors or hot gas bypass applications



Selection table T-Series

Series	Capacity R448A/R449A		Capacity R450A		Capacity R513A		Capacity R1234ze		Orifice Type	Power Element
	Type	[kW]	Type	[kW]	Type	[kW]	Type	[kW]		
TCLE-	25BW	1.9	20DW	1.3	20CW	1.3	20EW	1.1	X22440-B1B	XB1019...1B
	100BW	3.7	50DW	2.5	50CW	2.6	50EW	2.2	X22440-B2B	
	200BW	7.9	100DW	5.4	100CW	5.5	120EW	4.8	X22440-B3B	
	250BW	11.9	150DW	8.1	150CW	8.3	150EW	7.2	X22440-B3.5B	
	300BW	17.3	200DW	11.8	200CW	12.1	200EW	10.5	X22440-B4B	
	500BW	22.1	250DW	15.1	250CW	15.5	300EW	13.4	X22440-B5B	
	800BW	30.3	400DW	20.7	400CW	21.2	450EW	18.4	X22440-B6B	
	1100BW	41.0	500DW	28.0	500CW	28.7	600EW	24.8	X22440-B7B	
1300BW	47.7	600DW	32.6	600CW	33.4	700EW	28.9	X22440-B8B		
TJRE-	15BW	58	8DW	40	8CW	40	9EW	35	X11873-B4B	XB1019...1B
	18BW	74	9DW	50	9CW	52	10EW	45	X11873-B5B	
TERE	23BW	91	11DW	62	11CW	64	13EW	55	X9117-B6B	XC726...2B
	26BW	104	13DW	71	13CW	73	15EW	63	X9117-B7B	
	35BW	143	17DW	98	17CW	100	20EW	86	X9117-B8B	
	44BW	174	22DW	119	22CW	121	24EW	105	X9117-B9B	
TIRE-	60BW	222	31DW	152	31CW	156	35EW	135	X9166-B10B	XC726...2B
THRE-	78BW	252	38DW	173	38CW	177	43EW	153	X9144-B11B	
	98BW	301	47DW	206	47CW	211	53EW	183	X9144-B13B	

Note 1: For detailed information see flange table and connections sizes at the end of T-, L-, 935-, & ZZ Series chapter.

Note 2: Products are classified based on fluid group 2 (non-flammable) according European pressure equipment directive.

For selection of other operating condition, please use quick selection tables in the next pages or Controls Navigator selection program.

Thermo™-Expansion Valves T-, L-, 935-, ZZ-Series

The nominal capacity is based on the following conditions::

Refrigerant	Evaporating temperature [°C]	Condensing temperature [°C]	Subcooling
R448A, R449A	+4°C dew point	+38°C bubble / +43°C dew point	1K
R450A		+38°C bubble / +38.6°C dew point	
R513A, R1234ze		+38°C bubble / +38°C dew point	

Important consideration

In general, take a part valves are based on three different major parts i.e. power element, cage assembly and flange. It is important to consider the combination of power element with cage assembly as follows:

Valve series	Power element		Cage assembly type	Readjustment of cage assembly
	Type	Charge code		
T-series	XB-1019-...	BW, DW, CW, EW	X22440-B1B...B8B and X11873-B4B...B5B	Factory setting
		SW, MW		Filed setting is required
	XC-726-...	BW, DW, CW, EW	X9117-B6B...B13B	Factory setting
		SW, MW		Filed setting is required
ZZ-series	XC-726-...	BW, SW	X10-B1B...B7B	Filed setting is required
LL-series	XB-1019-...	CL, GL, UL	X22440-B1B...B8B and X11873-B4B...B5B	Factory setting
	XC726-...		X9117-B6B...B10B	
935-series	XB-1019-...	UL, KL, YL, JL, LL	X10-A/B/C01 A/B/C07	Factory setting

Note: BW, DW, CW, EW charges upon request and minimum 100 pieces order quantity.

The following table/graphic is a guideline for readjustment

Evaporating temperature [°C]	HFO Power element							
	XB-1019-MW...		XB-1019-SW...		XC726-MW...		XC726-SW...	
	System refrigerant							
	R450A	R513A	R1234ze	R448A/ R449A	R450A	R513A	R1234ze	R448A/ R449A
Number of turn				Number of turn				
-40	1.5	-1.5	3	6.5	2	-2	3.5	8.5
-35	2	-2	3.5	8	2.5	-2.5	5	10
-30	2.5	-2	4.5	9	3	-3	6	12
-25	3	-3	5.5	10.5	4	-3.5	7.5	13.5
-20	4	-3	7	12	5	-4	9.5	15.5
-15	4.5	-3.5	8.5	13.5	6	-5	11.5	18
-10	5.5	-4	10	15	7.5	-5.5	13.5	20
-5	6.5	-5	12.5	17	9	-6.5	16.5	-
0	8	-5.5	15	19	10.5	-7	-	-
5	9.5	-6	18	-	12.5	-8	-	-
10	11	-6.5	-	-	14.5	-9	-	-

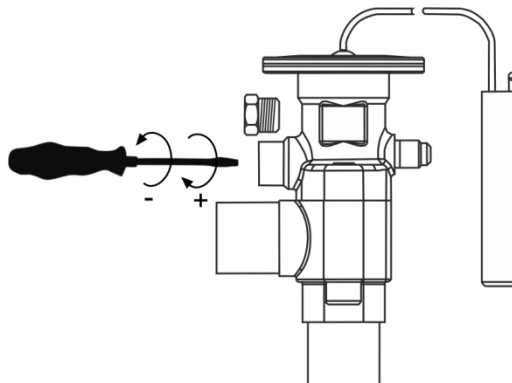

Note: Number of turns in direction of clockwise as positive number and in direction of counterclockwise as negative number.

Thermo™-Expansion Valves T-, L-, 935-, ZZ-Series

Type designation T-Series

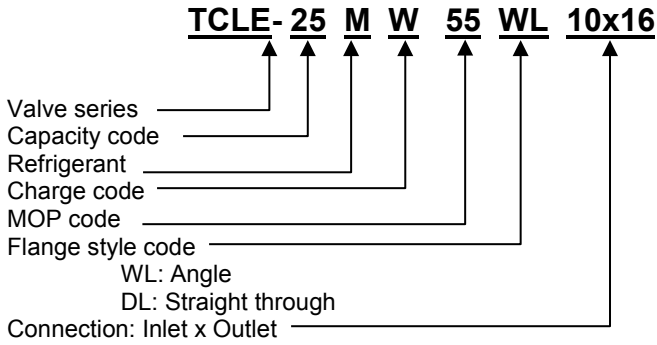

Selection table ZZ Series

Series	R448A/ R449A		Orifice	Connection Standard-Flange, Angle Solder/ODF		Power Element
	Type	Nominal Capacity [kW]		[mm]	[inch]	
ZZCE	1BW	1.7	X 10-B01	C501 – 5 mm 10 X 16	C501 - 5 3/8" X 5/8"	XC726 ... 2B
	2BW	3.7	X 10-B02			
	3BW	6.2	X 10-B03			
	5BW	9.8	X 10-B04	C501 – 7 mm 12 X 16	C501 - 7 1/2" X 5/8"	
	6BW	14.8	X 10-B05			
	10BW	19.8	X 10-B06	A 576 mm 16 X 22 (22 X 28 ODM)	A 576 5/8" X 7/8" (7/8" X 1 1/8" ODM)	
	12BW	24.7	X 10-B07			

Note 1: To withstand stress at extremely low temperatures, ZZ-Series valves feature bronze bolts

Note 2: See flange table and connection sizes at the end of T-, L-, 935-, & ZZ Series chapter.

Note 3: Products are classified based on fluid group 2 (non-flammable) according European pressure equipment directive.

For selection of other operating condition, please use quick selection tables in the next pages or Controls Navigator selection program.

Type designation ZZ-Series

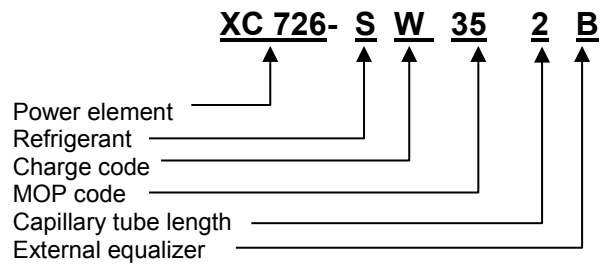
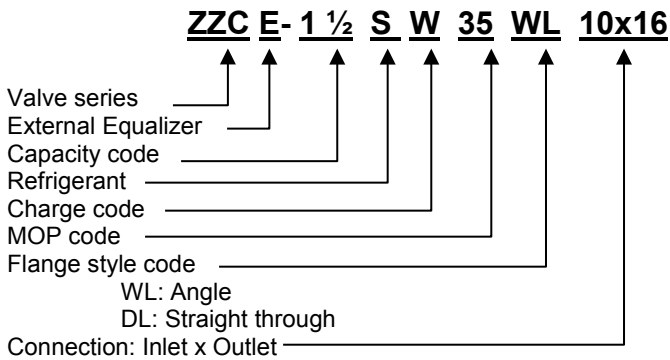

Thermo™-Expansion Valves T-, L-, 935-, ZZ-Series

TCLE: Quick selection (included 1.5 bar pressure drop for liquid line components and distributor)

Condensing temperature [°C]	R448A/R449A												Cage assembly type	
	Capacity [kW]													
	Evaporating temperature [°C]													
	15	10	5	0	-5	-10	-15	-20	-25	-30	-35	-40	-45	
60 bubble/ 63.4 dew point	1.7	1.7	1.8	1.8	1.7	1.7	1.5	1.3	1.1	0.9	0.7	0.6	0.5	X22440-B1B
	3.4	3.4	3.4	3.4	3.4	3.4	3.0	2.5	2.1	1.7	1.3	1.1	0.9	X22440-B2B
	7.2	7.3	7.3	7.3	7.2	7.2	6.3	5.4	4.4	3.6	2.9	2.3	1.9	X22440-B3B
	10.8	10.9	11.0	11.0	10.9	10.8	9.6	8.1	6.6	5.4	4.3	3.5	2.8	X22440-B3.5B
	15.7	15.9	16.0	16.0	15.9	15.7	13.9	11.7	9.6	7.8	6.3	5.1	4.1	X22440-B4B
	20.2	20.4	20.5	20.5	20.4	20.2	17.8	15.1	12.4	10.0	8.1	6.5	5.3	X22440-B5B
	27.7	28.0	28.1	28.1	27.9	27.6	24.4	20.6	16.9	13.7	11.0	8.9	7.2	X22440-B6B
	37.4	37.8	38.0	37.9	37.7	37.3	33.0	27.9	22.9	18.5	14.9	12.0	9.7	X22440-B7B
43.5	44.0	44.2	44.1	43.9	43.4	38.4	32.4	26.6	21.5	17.3	14.0	11.3	X22440-B8B	
50 bubble/ 54 dew point	1.8	1.8	1.8	1.8	1.9	1.9	1.7	1.4	1.2	0.9	0.8	0.6	0.5	X22440-B1B
	3.4	3.5	3.6	3.6	3.6	3.6	3.2	2.7	2.3	1.8	1.5	1.2	1.0	X22440-B2B
	7.3	7.5	7.6	7.7	7.7	7.7	6.9	5.9	4.8	3.9	3.2	2.6	2.1	X22440-B3B
	11.0	11.3	11.5	11.6	11.6	11.6	10.3	8.8	7.3	5.9	4.8	3.9	3.2	X22440-B3.5B
	16.0	16.4	16.7	16.8	16.9	16.9	15.0	12.8	10.6	8.6	7.0	5.7	4.6	X22440-B4B
	20.5	21.1	21.4	21.6	21.7	21.7	19.3	16.4	13.6	11.1	9.0	7.3	6.0	X22440-B5B
	28.1	28.8	29.3	29.6	29.7	29.7	26.4	22.5	18.6	15.2	12.3	10.0	8.2	X22440-B6B
	38.0	39.0	39.6	40.0	40.2	40.1	35.7	30.4	25.2	20.5	16.6	13.5	11.0	X22440-B7B
44.2	45.3	46.1	46.5	46.7	46.6	41.6	35.4	29.3	23.9	19.4	15.7	12.8	X22440-B8B	
40 bubble/ 44.5 dew point	1.6	1.7	1.8	1.8	1.9	1.9	1.7	1.4	1.2	1.0	0.8	0.7	0.5	X22440-B1B
	3.2	3.4	3.5	3.6	3.6	3.6	3.3	2.8	2.3	1.9	1.6	1.3	1.1	X22440-B2B
	6.8	7.2	7.4	7.6	7.7	7.8	7.0	6.0	5.0	4.1	3.3	2.7	2.2	X22440-B3B
	10.3	10.8	11.2	11.4	11.6	11.7	10.5	9.0	7.5	6.2	5.0	4.1	3.4	X22440-B3.5B
	15.0	15.7	16.2	16.6	16.9	17.0	15.3	13.1	10.9	9.0	7.3	6.0	4.9	X22440-B4B
	19.2	20.1	20.8	21.3	21.7	21.9	19.6	16.9	14.0	11.5	9.4	7.7	6.3	X22440-B5B
	26.3	27.6	28.5	29.2	29.7	29.9	26.9	23.1	19.2	15.8	12.9	10.5	8.6	X22440-B6B
	35.5	37.3	38.6	39.5	40.1	40.5	36.4	31.2	26.0	21.3	17.4	14.2	11.7	X22440-B7B
41.3	43.4	44.9	46.0	46.7	47.1	42.3	36.3	30.2	24.8	20.2	16.6	13.6	X22440-B8B	
30 bubble/ 33.5 dew point	1.4	1.5	1.6	1.7	1.7	1.8	1.6	1.4	1.2	1.0	0.8	0.7	0.5	X22440-B1B
	2.7	2.9	3.1	3.3	3.4	3.5	3.2	2.7	2.3	1.9	1.6	1.3	1.1	X22440-B2B
	5.7	6.3	6.7	7.0	7.3	7.4	6.8	5.9	4.9	4.1	3.3	2.7	2.3	X22440-B3B
	8.6	9.5	10.1	10.6	11.0	11.2	10.2	8.8	7.4	6.1	5.0	4.1	3.4	X22440-B3.5B
	12.5	13.7	14.7	15.4	15.9	16.3	14.8	12.8	10.8	8.9	7.3	6.0	5.0	X22440-B4B
	16.0	17.6	18.9	19.8	20.4	20.9	19.0	16.5	13.8	11.4	9.4	7.7	6.4	X22440-B5B
	21.9	24.2	25.8	27.1	28.0	28.6	26.0	22.6	18.9	15.6	12.9	10.6	8.7	X22440-B6B
	29.6	32.7	34.9	36.6	37.9	38.7	35.2	30.5	25.6	21.2	17.4	14.3	11.8	X22440-B7B
34.4	38.0	40.6	42.6	44.0	45.0	40.9	35.5	29.8	24.6	20.2	16.6	13.7	X22440-B8B	
20 bubble/ 25.3 dew point	1.1	1.3	1.4	1.5	1.5	1.6	1.5	1.3	1.1	0.9	0.8	0.6	0.5	X22440-B1B
	2.2	2.5	2.8	3.0	3.1	3.2	2.9	2.6	2.2	1.8	1.5	1.2	1.0	X22440-B2B
	4.6	5.4	6.0	6.4	6.7	6.8	6.2	5.5	4.6	3.9	3.2	2.6	2.2	X22440-B3B
	6.9	8.1	9.0	9.6	10.1	10.3	9.3	8.2	7.0	5.8	4.8	4.0	3.3	X22440-B3.5B
	10.1	11.8	13.1	14.0	14.7	15.1	13.6	11.9	10.1	8.5	7.0	5.8	4.8	X22440-B4B
	12.9	15.2	16.8	18.0	18.8	19.4	17.4	15.3	13.0	10.8	9.0	7.4	6.2	X22440-B5B
	17.7	20.8	23.0	24.6	25.8	26.6	23.9	21.0	17.8	14.9	12.3	10.2	8.5	X22440-B6B
	24.0	28.1	31.1	33.2	34.9	36.3	32.3	28.4	24.1	20.1	16.6	13.8	11.4	X22440-B7B
27.9	32.7	36.1	38.7	40.5	42.3	37.5	33.0	28.0	23.4	19.3	16.0	13.3	X22440-B8B	
10 bubble/ 15.5 dew point	1.0	1.2	1.3	1.3	1.1	1.0	0.8	0.7	0.6	0.5	0.5	0.5	0.5	X22440-B1B
	1.9	2.3	2.6	2.5	2.2	1.9	1.6	1.4	1.1	1.0	0.9	0.8	0.7	X22440-B2B
	4.1	4.9	5.5	5.3	4.8	4.1	3.5	2.9	2.4	2.0	1.8	1.6	1.4	X22440-B3B
	6.2	7.4	8.2	7.9	7.2	6.2	5.3	4.4	3.7	3.1	2.7	2.4	2.1	X22440-B3.5B
	9.0	10.8	12.0	11.5	10.4	9.0	7.6	6.4	5.3	4.5	3.8	3.3	2.9	X22440-B4B
	11.6	13.8	15.4	14.8	13.4	11.6	9.8	8.2	6.9	5.7	4.8	4.1	3.6	X22440-B5B
	15.9	18.9	21.1	20.3	18.3	15.9	13.4	11.2	9.4	7.9	6.6	5.6	4.8	X22440-B6B
	21.5	25.6	28.5	27.4	24.8	21.4	18.1	15.2	12.7	10.6	8.9	7.6	6.5	X22440-B7B
25.0	29.8	33.1	31.9	28.8	24.9	21.1	17.7	14.8	12.4	10.4	8.9	7.6	X22440-B8B	

Thermo™-Expansion Valves T-, L-, 935-, ZZ-Series

TJRE/TERE/TIRE/THRE: Quick selection (included 1.5 bar pressure drop for liquid line components and distributor)

Condensing temperature [°C]	R448A/R449A				Capacity [kW]									R448A/R449A	Cage assembly type
	Evaporating temperature [°C]														
	15	10	5	0	-5	-10	-15	-20	-25	-30	-35	-40	-45		
60 bubble/ 63.4 dew point	53	53	54	54	53	53	47	39	32	26	21	17	14	X11873-B4B	
	67	68	68	68	68	67	59	50	41	33	27	22	18	X11873-B5B	
	83	84	84	84	83	83	73	62	51	41	33	27	22	X9117-B6B	
	95	96	96	96	95	94	84	71	58	47	38	30	25	X9117-B7B	
	130	132	132	132	131	130	115	97	80	64	52	42	34	X9117-B8B	
	158	160	161	161	160	158	140	118	97	78	63	51	41	X9117-B9B	
	203	205	206	206	205	203	179	151	124	100	81	65	53	X9166-B10B	
	230	233	234	233	232	230	203	172	141	114	92	74	60	X9144-B11B	
	275	278	279	279	277	274	242	205	168	136	110	88	72	X9144-B13B	
50 bubble/ 54 dew point	54	55	56	56	57	57	50	43	36	29	23	19	16	X11873-B4B	
	68	70	71	72	72	72	64	55	45	37	30	24	20	X11873-B5B	
	84	86	88	89	89	89	79	67	56	45	37	30	24	X9117-B6B	
	96	99	100	101	102	101	90	77	64	52	42	34	28	X9117-B7B	
	132	136	138	139	140	140	124	106	88	71	58	47	38	X9117-B8B	
	161	165	168	169	170	170	151	129	107	87	70	57	47	X9117-B9B	
	206	212	215	217	218	218	194	165	137	111	90	73	60	X9166-B10B	
	234	240	244	246	247	247	220	187	155	126	102	83	68	X9144-B11B	
	279	286	291	294	295	295	263	224	185	151	122	99	81	X9144-B13B	
40 bubble/ 44.5 dew point	50	53	54	56	57	57	51	44	37	30	25	20	16	X11873-B4B	
	64	67	69	71	72	73	65	56	47	38	31	26	21	X11873-B5B	
	79	83	85	87	89	90	81	69	58	47	39	32	26	X9117-B6B	
	90	94	98	100	102	102	92	79	66	54	44	36	30	X9117-B7B	
	124	130	134	137	140	141	127	109	90	74	61	50	41	X9117-B8B	
	150	158	163	167	170	171	154	132	110	90	74	60	49	X9117-B9B	
	193	202	209	214	218	220	197	169	141	116	94	77	63	X9166-B10B	
	219	230	238	243	247	249	224	192	160	131	107	88	72	X9144-B11B	
	261	274	284	290	295	297	267	229	191	157	128	105	86	X9144-B13B	
30 bubble/ 33.5 dew point	42	46	49	52	53	55	50	43	36	30	25	20	17	X11873-B4B	
	53	59	63	66	68	70	63	55	46	38	31	26	21	X11873-B5B	
	66	72	77	81	84	86	78	68	57	47	38	32	26	X9117-B6B	
	75	83	88	93	96	98	89	77	65	54	44	36	30	X9117-B7B	
	103	114	122	127	132	135	122	106	89	74	60	50	41	X9117-B8B	
	125	138	148	155	160	164	149	129	108	90	74	60	50	X9117-B9B	
	161	177	189	199	205	210	191	166	139	115	94	78	64	X9166-B10B	
	182	201	215	225	233	238	217	188	158	130	107	88	73	X9144-B11B	
	218	240	257	269	278	284	259	224	188	155	128	105	87	X9144-B13B	
20 bubble/ 25.3 dew point		34	40	44	47	49	46	40	34	28	23	19	16	X11873-B4B	
		43	51	56	60	63	58	51	43	36	30	25	21	X11873-B5B	
		53	62	69	74	77	71	63	53	44	37	30	25	X9117-B6B	
		61	71	79	84	88	82	72	61	51	42	35	29	X9117-B7B	
		83	98	108	116	121	112	99	84	70	58	48	40	X9117-B8B	
		101	119	131	141	148	137	120	102	85	70	58	48	X9117-B9B	
		130	152	168	180	189	175	154	131	109	90	75	62	X9166-B10B	
		148	173	191	205	215	199	175	148	124	102	85	70	X9144-B11B	
	176	206	228	244	256	237	209	177	148	122	101	84	X9144-B13B		
10 bubble/ 15.5 dew point				30	36	40	39	35	30	26	21	18	15	X11873-B4B	
				39	46	51	49	45	39	33	27	23	19	X11873-B5B	
				48	57	63	61	55	47	40	34	28	24	X9117-B6B	
				54	65	72	69	63	54	46	38	32	27	X9117-B7B	
				75	89	99	95	86	75	63	53	44	37	X9117-B8B	
				91	108	121	116	105	91	77	64	54	45	X9117-B9B	
				117	139	155	149	134	116	98	82	69	58	X9166-B10B	
				132	158	175	169	152	132	112	94	78	65	X9144-B11B	
			158	188	209	202	182	158	133	112	93	78	X9144-B13B		

Thermo™-Expansion Valves T-, L-, 935-, ZZ-Series

TCLE: Quick selection (included 1.5 bar pressure drop for liquid line components and distributor)

Condensing temperature [°C]	R450A/R513A													Cage assembly type
	Capacity [kW]													
	Evaporating temperature [°C]													
	30	25	20	15	10	5	0	-5	-10	-15	-20	-25	-30	
80	1.2	1.2	1.2	1.2	1.2	1.1	1.1	1.1	1.0	0.9	0.7	0.5	0.4	X22440-B1B
	2.4	2.4	2.3	2.3	2.3	2.2	2.1	2.1	2.0	1.7	1.4	1.1	0.8	X22440-B2B
	5.1	5.0	5.0	4.9	4.8	4.7	4.5	4.4	4.2	3.6	2.9	2.3	1.7	X22440-B3B
	7.6	7.6	7.5	7.4	7.2	7.1	6.8	6.6	6.3	5.5	4.4	3.4	2.6	X22440-B3.5B
	11.1	11.0	10.9	10.8	10.5	10.3	9.9	9.6	9.2	8.0	6.4	5.0	3.8	X22440-B4B
	14.2	14.2	14.0	13.8	13.5	13.2	12.8	12.3	11.8	10.3	8.3	6.4	4.8	X22440-B5B
	19.5	19.4	19.2	18.9	18.5	18.0	17.5	16.9	16.2	14.0	11.3	8.8	6.6	X22440-B6B
	26.3	26.2	26.0	25.6	25.0	24.4	23.6	22.8	21.9	19.0	15.3	11.8	9.0	X22440-B7B
	30.6	30.5	30.2	29.7	29.1	28.4	27.5	26.5	25.5	22.1	17.8	13.8	10.4	X22440-B8B
70	1.3	1.3	1.3	1.3	1.3	1.3	1.2	1.2	1.2	1.0	0.8	0.7	0.5	X22440-B1B
	2.4	2.5	2.5	2.5	2.5	2.4	2.4	2.3	2.3	2.0	1.6	1.3	1.0	X22440-B2B
	5.2	5.3	5.3	5.3	5.3	5.2	5.1	5.0	4.9	4.3	3.5	2.7	2.1	X22440-B3B
	7.9	8.0	8.0	8.0	7.9	7.8	7.7	7.5	7.3	6.4	5.3	4.1	3.2	X22440-B3.5B
	11.4	11.6	11.7	11.6	11.5	11.4	11.2	10.9	10.6	9.3	7.7	6.0	4.6	X22440-B4B
	14.7	14.9	15.0	14.9	14.8	14.6	14.3	14.0	13.6	12.0	9.8	7.7	5.9	X22440-B5B
	20.1	20.4	20.5	20.4	20.3	20.0	19.6	19.2	18.7	16.4	13.4	10.6	8.1	X22440-B6B
	27.2	27.5	27.7	27.6	27.4	27.1	26.6	26.0	25.3	22.2	18.2	14.3	11.0	X22440-B7B
	31.6	32.0	32.2	32.2	31.9	31.5	30.9	30.2	29.4	25.8	21.1	16.6	12.8	X22440-B8B
60	1.2	1.2	1.3	1.3	1.3	1.3	1.3	1.3	1.2	1.1	0.9	0.7	0.6	X22440-B1B
	2.3	2.4	2.5	2.5	2.5	2.5	2.5	2.5	2.4	2.2	1.8	1.4	1.1	X22440-B2B
	4.9	5.1	5.3	5.3	5.4	5.4	5.3	5.3	5.2	4.6	3.8	3.0	2.4	X22440-B3B
	7.4	7.7	7.9	8.0	8.1	8.1	8.0	7.9	7.8	6.9	5.7	4.5	3.5	X22440-B3.5B
	10.8	11.2	11.5	11.7	11.8	11.8	11.7	11.5	11.3	10.1	8.3	6.6	5.2	X22440-B4B
	13.8	14.4	14.8	15.0	15.1	15.1	15.0	14.8	14.6	12.9	10.7	8.5	6.6	X22440-B5B
	18.9	19.7	20.2	20.5	20.7	20.7	20.5	20.3	19.9	17.7	14.6	11.6	9.1	X22440-B6B
	25.6	26.6	27.3	27.8	27.9	27.9	27.7	27.4	26.9	23.9	19.8	15.7	12.2	X22440-B7B
	29.8	31.0	31.8	32.3	32.5	32.5	32.3	31.9	31.3	27.8	23.0	18.3	14.2	X22440-B8B
50	1.0	1.1	1.2	1.2	1.2	1.3	1.3	1.3	1.3	1.1	0.9	0.8	0.6	X22440-B1B
	1.9	2.1	2.2	2.3	2.4	2.4	2.5	2.5	2.4	2.2	1.8	1.5	1.2	X22440-B2B
	4.1	4.5	4.8	5.0	5.1	5.2	5.2	5.2	5.2	4.7	3.9	3.1	2.5	X22440-B3B
	6.1	6.8	7.2	7.5	7.7	7.9	7.9	7.9	7.9	7.1	5.9	4.7	3.7	X22440-B3.5B
	8.9	9.8	10.5	10.9	11.2	11.4	11.5	11.5	11.4	10.3	8.6	6.9	5.4	X22440-B4B
	11.5	12.6	13.4	14.0	14.4	14.6	14.8	14.8	14.7	13.2	11.0	8.8	6.9	X22440-B5B
	15.7	17.3	18.4	19.2	19.7	20.1	20.2	20.2	20.1	18.0	15.0	12.0	9.5	X22440-B6B
	21.2	23.4	24.9	26.0	26.7	27.1	27.3	27.3	27.1	24.4	20.3	16.3	12.8	X22440-B7B
	24.7	27.2	29.0	30.2	31.0	31.5	31.8	31.8	31.6	28.3	23.7	18.9	14.9	X22440-B8B
40	0.5	0.8	0.9	1.0	1.1	1.1	1.2	1.2	1.2	1.1	0.9	0.7	0.6	X22440-B1B
	1.0	1.5	1.8	2.0	2.1	2.2	2.3	2.3	2.3	2.1	1.8	1.4	1.1	X22440-B2B
	2.2	3.2	3.8	4.2	4.5	4.7	4.9	4.9	5.0	4.5	3.8	3.1	2.4	X22440-B3B
	3.4	4.8	5.7	6.3	6.8	7.1	7.3	7.4	7.5	6.8	5.7	4.6	3.7	X22440-B3.5B
	4.9	7.0	8.3	9.2	9.9	10.3	10.6	10.8	10.9	9.9	8.4	6.8	5.4	X22440-B4B
	6.3	9.0	10.7	11.8	12.7	13.3	13.6	13.9	14.0	12.7	10.7	8.7	6.9	X22440-B5B
	8.6	12.3	14.6	16.2	17.4	18.2	18.7	19.0	19.2	17.4	14.7	11.9	9.4	X22440-B6B
	11.6	16.6	19.7	21.9	23.5	24.5	25.3	25.7	25.9	23.5	19.8	16.0	12.7	X22440-B7B
	13.5	19.3	23.0	25.5	27.3	28.5	29.4	29.9	30.1	27.4	23.1	18.7	14.8	X22440-B8B
30			0.4	0.7	0.8	0.9	1.0	1.0	1.1	1.0	0.8	0.7	0.6	X22440-B1B
			0.7	1.3	1.6	1.8	1.9	2.0	2.1	1.9	1.6	1.3	1.1	X22440-B2B
			1.6	2.7	3.4	3.8	4.1	4.3	4.5	4.1	3.5	2.9	2.3	X22440-B3B
			2.4	4.1	5.1	5.7	6.2	6.5	6.7	6.2	5.3	4.3	3.5	X22440-B3.5B
			3.5	6.0	7.4	8.3	9.0	9.4	9.7	9.0	7.7	6.3	5.1	X22440-B4B
			4.5	7.6	9.5	10.7	11.5	12.1	12.5	11.6	9.9	8.1	6.5	X22440-B5B
			6.2	10.5	13.0	14.6	15.8	16.6	17.1	15.8	13.6	11.1	8.9	X22440-B6B
			8.3	14.2	17.5	19.8	21.3	22.4	23.2	21.4	18.3	15.0	12.0	X22440-B7B
		9.7	16.5	20.4	23.0	24.8	26.1	26.9	24.9	21.3	17.4	14.0	X22440-B8B	

Thermo™-Expansion Valves T-, L-, 935-, ZZ-Series

TJRE/TERE/TIRE/THRE: Quick selection (included 1.5 bar pressure drop for liquid line components and distributor)

Condensing temperature [°C]	R450A/R513A													Cage assembly type
	Capacity [kW]													
	Evaporating temperature [°C]													
	30	25	20	15	10	5	0	-5	-10	-15	-20	-25	-30	
80	37	37	37	36	35	34	33	32	31	27	22	17	13	X11873-B4B
	47	47	47	46	45	44	43	41	39	34	28	21	16	X11873-B5B
	58	58	58	57	55	54	52	50	48	42	34	26	20	X9117-B6B
	67	66	66	65	63	62	60	58	55	48	39	30	23	X9117-B7B
	92	91	90	89	87	85	82	79	76	66	53	41	31	X9117-B8B
	111	111	110	108	106	103	100	97	93	80	65	50	38	X9117-B9B
	143	142	141	139	136	132	128	124	119	103	83	64	49	X9166-B10B
	162	162	160	157	154	150	145	140	135	117	94	73	55	X9144-B11B
	193	193	191	188	184	179	174	168	161	139	113	87	66	X9144-B13B
70	38	39	39	39	39	38	37	37	36	31	26	20	16	X11873-B4B
	49	50	50	50	49	49	48	47	45	40	33	26	20	X11873-B5B
	60	61	61	61	61	60	59	57	56	49	40	32	24	X9117-B6B
	69	70	70	70	69	68	67	66	64	56	46	36	28	X9117-B7B
	94	96	96	96	95	94	92	90	88	77	63	50	38	X9117-B8B
	115	117	117	117	116	115	112	110	107	94	77	60	47	X9117-B9B
	147	149	150	150	149	147	144	141	137	120	99	77	60	X9166-B10B
	167	170	170	170	169	167	163	160	155	137	112	88	68	X9144-B11B
	200	202	204	203	202	199	195	191	186	163	134	105	81	X9144-B13B
60	36	38	39	39	39	39	39	39	38	34	28	22	17	X11873-B4B
	46	48	49	50	50	50	50	49	49	43	36	28	22	X11873-B5B
	57	59	61	61	62	62	61	61	60	53	44	35	27	X9117-B6B
	65	67	69	70	71	71	70	69	68	61	50	40	31	X9117-B7B
	89	93	95	97	97	97	96	95	94	83	69	55	43	X9117-B8B
	108	113	116	118	118	118	117	116	114	101	84	67	52	X9117-B9B
	139	145	148	151	152	151	150	149	146	130	107	85	66	X9166-B10B
	158	164	168	171	172	172	171	169	166	147	122	97	75	X9144-B11B
	188	196	201	204	205	205	204	201	198	176	145	115	90	X9144-B13B
50	30	33	35	37	38	38	39	39	38	34	29	23	18	X11873-B4B
	38	42	45	47	48	49	49	49	49	44	37	29	23	X11873-B5B
	47	52	55	57	59	60	60	60	60	54	45	36	28	X9117-B6B
	54	59	63	66	68	69	69	69	69	62	51	41	32	X9117-B7B
	74	81	87	90	93	94	95	95	94	85	71	57	45	X9117-B8B
	90	99	105	110	113	115	116	116	115	103	86	69	54	X9117-B9B
	115	127	135	141	145	147	148	148	147	132	110	88	69	X9166-B10B
	131	144	153	160	164	167	168	168	167	150	125	100	79	X9144-B11B
	156	172	183	191	196	199	201	201	199	179	149	120	94	X9144-B13B
40	16	23	28	31	33	35	36	36	37	33	28	23	18	X11873-B4B
	21	30	36	39	42	44	45	46	47	42	36	29	23	X11873-B5B
	26	37	44	49	52	54	56	57	57	52	44	36	28	X9117-B6B
	29	42	50	55	59	62	64	65	66	60	50	41	32	X9117-B7B
	40	58	69	76	82	85	88	89	90	82	69	56	44	X9117-B8B
	49	70	84	93	99	104	107	109	110	100	84	68	54	X9117-B9B
	63	90	107	119	127	133	137	139	141	128	108	87	69	X9166-B10B
	71	102	121	135	144	151	156	158	160	145	122	99	78	X9144-B11B
	85	122	145	161	172	180	186	189	190	173	146	118	93	X9144-B13B
30			12	20	25	28	30	32	33	30	26	21	17	X11873-B4B
			15	25	32	36	38	40	42	39	33	27	22	X11873-B5B
			18	31	39	44	47	50	51	47	41	33	27	X9117-B6B
			21	36	44	50	54	57	59	54	46	38	30	X9117-B7B
			29	49	61	69	74	78	81	74	64	52	42	X9117-B8B
			35	60	74	84	90	95	98	91	78	63	51	X9117-B9B
			45	77	95	107	116	122	126	116	99	81	65	X9166-B10B
			51	87	108	122	131	138	143	132	113	92	74	X9144-B11B
		61	104	129	145	157	165	170	157	135	110	88	X9144-B13B	

Thermo™-Expansion Valves T-, L-, 935-, ZZ-Series

TCLE: Quick selection (included 1.5 bar pressure drop for liquid line components and distributor)

Condensing temperature [°C]	R1234ze													Cage assembly type
	Capacity [kW]													
	Evaporating temperature [°C]													
	30	25	20	15	10	5	0	-5	-10	-15	-20	-25	-30	
80	1.1	1.1	1.1	1.1	1.0	1.0	1.0	0.9	0.9	0.8	0.6	0.5	0.4	X22440-B1B
	2.2	2.2	2.1	2.1	2.0	2.0	1.9	1.8	1.7	1.5	1.2	0.9	0.7	X22440-B2B
	4.6	4.6	4.5	4.4	4.3	4.2	4.1	3.9	3.7	3.2	2.6	2.0	1.5	X22440-B3B
	7.0	6.9	6.8	6.7	6.5	6.3	6.1	5.9	5.6	4.9	3.9	3.0	2.2	X22440-B3.5B
	10.1	10.1	9.9	9.7	9.5	9.2	8.9	8.5	8.2	7.1	5.7	4.4	3.3	X22440-B4B
	13.0	12.9	12.7	12.5	12.2	11.8	11.4	11.0	10.5	9.1	7.3	5.6	4.2	X22440-B5B
	17.8	17.7	17.4	17.1	16.7	16.2	15.6	15.0	14.3	12.4	10.0	7.6	5.7	X22440-B6B
	24.1	23.9	23.6	23.1	22.6	21.9	21.1	20.3	19.4	16.8	13.5	10.3	7.8	X22440-B7B
	28.0	27.8	27.4	26.9	26.2	25.5	24.6	23.6	22.6	19.5	15.7	12.0	9.0	X22440-B8B
70	1.1	1.1	1.1	1.1	1.1	1.1	1.1	1.1	1.0	0.9	0.7	0.6	0.4	X22440-B1B
	2.2	2.2	2.2	2.2	2.2	2.2	2.1	2.1	2.0	1.8	1.4	1.1	0.9	X22440-B2B
	4.7	4.8	4.8	4.8	4.7	4.6	4.5	4.4	4.3	3.8	3.1	2.4	1.8	X22440-B3B
	7.1	7.2	7.2	7.2	7.1	7.0	6.8	6.6	6.4	5.7	4.6	3.6	2.8	X22440-B3.5B
	10.3	10.4	10.5	10.4	10.3	10.1	9.9	9.7	9.4	8.2	6.7	5.2	4.0	X22440-B4B
	13.2	13.4	13.4	13.4	13.2	13.0	12.7	12.4	12.0	10.5	8.6	6.7	5.1	X22440-B5B
	18.1	18.3	18.4	18.3	18.1	17.8	17.4	17.0	16.5	14.4	11.8	9.2	7.0	X22440-B6B
	24.4	24.8	24.8	24.7	24.5	24.1	23.6	23.0	22.3	19.5	16.0	12.5	9.5	X22440-B7B
	28.4	28.8	28.9	28.8	28.5	28.0	27.4	26.7	25.9	22.7	18.6	14.5	11.1	X22440-B8B
60	1.0	1.1	1.1	1.1	1.1	1.1	1.1	1.1	1.1	1.0	0.8	0.6	0.5	X22440-B1B
	2.0	2.1	2.2	2.2	2.2	2.2	2.2	2.2	2.1	1.9	1.6	1.2	1.0	X22440-B2B
	4.4	4.5	4.7	4.7	4.8	4.7	4.7	4.6	4.5	4.0	3.3	2.6	2.0	X22440-B3B
	6.6	6.8	7.0	7.1	7.2	7.1	7.1	7.0	6.8	6.1	5.0	4.0	3.1	X22440-B3.5B
	9.5	9.9	10.2	10.4	10.4	10.4	10.3	10.1	9.9	8.8	7.3	5.8	4.5	X22440-B4B
	12.2	12.8	13.1	13.3	13.4	13.3	13.2	13.0	12.8	11.3	9.4	7.4	5.7	X22440-B5B
	16.8	17.5	17.9	18.2	18.3	18.2	18.1	17.8	17.5	15.5	12.8	10.1	7.8	X22440-B6B
	22.7	23.6	24.3	24.6	24.7	24.7	24.4	24.1	23.6	21.0	17.3	13.7	10.6	X22440-B7B
	26.4	27.5	28.2	28.6	28.8	28.7	28.4	28.0	27.5	24.4	20.2	15.9	12.3	X22440-B8B
50	0.8	0.9	1.0	1.0	1.1	1.1	1.1	1.1	1.1	1.0	0.8	0.7	0.5	X22440-B1B
	1.6	1.8	2.0	2.0	2.1	2.1	2.1	2.1	2.1	1.9	1.6	1.3	1.0	X22440-B2B
	3.5	3.9	4.2	4.4	4.5	4.6	4.6	4.6	4.5	4.1	3.4	2.7	2.1	X22440-B3B
	5.3	5.9	6.3	6.6	6.8	6.9	6.9	6.9	6.8	6.1	5.1	4.1	3.2	X22440-B3.5B
	7.7	8.5	9.1	9.5	9.8	10.0	10.0	10.0	10.0	8.9	7.5	5.9	4.6	X22440-B4B
	9.8	10.9	11.7	12.3	12.6	12.8	12.9	12.9	12.8	11.5	9.6	7.6	6.0	X22440-B5B
	13.5	15.0	16.0	16.8	17.3	17.5	17.6	17.6	17.5	15.7	13.1	10.5	8.2	X22440-B6B
	18.2	20.3	21.7	22.7	23.3	23.7	23.9	23.8	23.7	21.2	17.7	14.1	11.0	X22440-B7B
	21.2	23.6	25.2	26.4	27.1	27.6	27.8	27.7	27.5	24.7	20.6	16.4	12.8	X22440-B8B
40	0.4	0.6	0.8	0.9	0.9	1.0	1.0	1.0	1.0	0.9	0.8	0.6	0.5	X22440-B1B
	0.7	1.2	1.5	1.7	1.8	1.9	2.0	2.0	2.0	1.8	1.5	1.2	1.0	X22440-B2B
	1.5	2.6	3.2	3.6	3.9	4.1	4.2	4.3	4.3	3.9	3.3	2.7	2.1	X22440-B3B
	2.2	3.8	4.8	5.4	5.8	6.1	6.3	6.4	6.5	5.9	5.0	4.0	3.2	X22440-B3.5B
	3.2	5.6	6.9	7.8	8.5	8.9	9.2	9.3	9.4	8.5	7.2	5.8	4.6	X22440-B4B
	4.1	7.2	8.9	10.1	10.9	11.4	11.8	12.0	12.1	11.0	9.3	7.5	5.9	X22440-B5B
	5.7	9.8	12.2	13.8	14.9	15.6	16.1	16.4	16.5	15.0	12.7	10.2	8.1	X22440-B6B
	7.7	13.3	16.5	18.6	20.1	21.1	21.8	22.2	22.3	20.3	17.2	13.8	10.9	X22440-B7B
	8.9	15.5	19.2	21.6	23.4	24.5	25.3	25.8	26.0	23.6	20.0	16.1	12.7	X22440-B8B
30			0.0	0.5	0.6	0.8	0.8	0.9	0.9	0.8	0.7	0.6	0.5	X22440-B1B
			0.1	0.9	1.3	1.5	1.6	1.7	1.8	1.6	1.4	1.1	0.9	X22440-B2B
			0.2	2.0	2.7	3.1	3.4	3.6	3.8	3.5	3.0	2.5	2.0	X22440-B3B
			0.3	3.0	4.1	4.7	5.2	5.5	5.7	5.3	4.5	3.7	2.9	X22440-B3.5B
			0.5	4.4	5.9	6.9	7.5	8.0	8.3	7.7	6.6	5.4	4.3	X22440-B4B
			0.6	5.7	7.6	8.8	9.6	10.2	10.6	9.8	8.4	6.9	5.5	X22440-B5B
			0.8	7.8	10.4	12.1	13.2	14.0	14.5	13.5	11.6	9.4	7.5	X22440-B6B
			1.1	10.5	14.1	16.3	17.9	18.9	19.6	18.2	15.6	12.8	10.2	X22440-B7B
		1.2	12.2	16.3	19.0	20.8	22.0	22.8	21.2	18.2	14.8	11.8	X22440-B8B	

Note: Products are classified based on fluid group 2 (non-flammable) according European pressure equipment directive.

Thermo™-Expansion Valves T-, L-, 935-, ZZ-Series

TJRE/TERE/TIRE/THRE: Quick selection (included 1.5 bar pressure drop for liquid line components and distributor)

Condensing temperature [°C]	R1234ze													Cage assembly type
	Capacity [kW]													
	Evaporating temperature [°C]													
	30	25	20	15	10	5	0	-5	-10	-15	-20	-25	-30	
80	34	34	33	33	32	31	30	29	27	24	19	15	11	X11873-B4B
	43	43	42	42	41	39	38	37	35	30	24	19	14	X11873-B5B
	53	53	52	51	50	48	47	45	43	37	30	23	17	X9117-B6B
	61	60	60	59	57	55	53	51	49	42	34	26	20	X9117-B7B
	84	83	82	80	78	76	74	71	67	58	47	36	27	X9117-B8B
	102	101	100	98	96	93	89	86	82	71	57	44	33	X9117-B9B
	130	130	128	126	122	119	115	110	105	91	73	56	42	X9166-B10B
	148	147	145	142	139	135	130	125	119	103	83	64	48	X9144-B11B
	177	176	173	170	166	161	155	149	143	123	99	76	57	X9144-B13B
70	35	35	35	35	35	34	33	32	31	28	23	18	13	X11873-B4B
	44	45	45	45	44	43	42	41	40	35	29	22	17	X11873-B5B
	54	55	55	55	54	53	52	51	49	43	35	28	21	X9117-B6B
	62	63	63	63	62	61	60	58	56	49	40	32	24	X9117-B7B
	85	86	86	86	85	84	82	80	77	68	56	43	33	X9117-B8B
	104	105	105	105	104	102	100	97	94	83	68	53	40	X9117-B9B
	133	134	135	134	133	131	128	125	121	106	87	68	52	X9166-B10B
	151	152	153	152	151	148	145	141	137	120	98	77	59	X9144-B11B
	180	182	183	182	180	177	173	169	164	144	117	92	70	X9144-B13B
60	32	33	34	35	35	35	34	34	33	30	24	19	15	X11873-B4B
	41	43	44	44	45	44	44	43	43	38	31	25	19	X11873-B5B
	50	52	54	54	55	55	54	53	52	46	38	30	23	X9117-B6B
	57	60	61	62	63	62	62	61	60	53	44	35	27	X9117-B7B
	79	82	84	86	86	86	85	84	82	73	60	48	37	X9117-B8B
	96	100	103	104	105	104	103	102	100	89	73	58	45	X9117-B9B
	123	128	132	133	134	134	133	131	128	114	94	74	58	X9166-B10B
	140	145	149	151	152	152	150	148	145	129	107	84	65	X9144-B11B
	167	174	178	181	182	181	180	177	174	154	127	101	78	X9144-B13B
50	26	29	31	32	33	33	34	34	33	30	25	20	16	X11873-B4B
	33	36	39	41	42	43	43	43	43	38	32	25	20	X11873-B5B
	40	45	48	50	52	52	53	53	52	47	39	31	24	X9117-B6B
	46	51	55	57	59	60	60	60	60	54	45	36	28	X9117-B7B
	63	70	75	79	81	82	83	83	82	74	62	49	38	X9117-B8B
	77	86	92	96	99	100	101	101	100	90	75	60	47	X9117-B9B
	99	110	118	123	127	129	129	129	128	115	96	77	60	X9166-B10B
	112	125	134	140	144	146	147	147	146	131	109	87	68	X9144-B11B
	134	149	159	167	171	174	175	175	174	156	130	104	81	X9144-B13B
40	11	19	23	26	28	30	31	31	32	29	24	20	15	X11873-B4B
	14	24	30	34	36	38	39	40	40	37	31	25	20	X11873-B5B
	17	29	36	41	44	47	48	49	49	45	38	31	24	X9117-B6B
	19	34	42	47	51	53	55	56	57	51	43	35	28	X9117-B7B
	27	46	57	65	70	73	76	77	78	71	60	48	38	X9117-B8B
	32	56	70	79	85	89	92	94	95	86	73	59	46	X9117-B9B
	42	72	89	101	109	115	118	120	121	110	93	75	59	X9166-B10B
	47	82	101	115	124	130	134	136	138	125	106	85	67	X9144-B11B
	56	98	121	137	148	155	160	163	164	149	126	102	80	X9144-B13B
30			2	15	20	23	25	27	28	26	22	18	14	X11873-B4B
			2	19	25	29	32	34	35	33	28	23	18	X11873-B5B
			2	23	31	36	40	42	43	40	35	28	23	X9117-B6B
			3	27	36	41	45	48	50	46	40	32	26	X9117-B7B
			4	36	49	57	62	66	68	63	54	44	35	X9117-B8B
			5	44	60	69	76	80	83	77	66	54	43	X9117-B9B
			6	57	76	89	97	103	106	99	85	69	55	X9166-B10B
			7	65	87	100	110	116	121	112	96	79	63	X9144-B11B
		8	77	103	120	131	139	144	134	115	94	75	X9144-B13B	

Note 1: Products are classified based on fluid group 2 (non-flammable) according European pressure equipment directive.

Thermo™-Expansion Valves T-, L-, 935-, ZZ-Series

ZZ-Series: Quick selection (included 1.5 bar pressure drop for liquid line components and distributor)

Condensing temperature [°C]	Capacity [kW]								Cage assembly type
	Evaporating temperature [°C]								
	-40	-45	-50	-55	-60	-65	-70	-75	
40 bubble/ 44.5 dew point	1.7	1.4	1.1	0.9	0.7	0.6	0.4	0.3	X10-B01
	3.5	2.9	2.4	1.9	1.5	1.2	0.9	0.7	X10-B02
	5.9	4.9	4.0	3.2	2.6	2.0	1.6	1.2	X10-B03
	9.4	7.8	6.4	5.1	4.1	3.2	2.5	1.9	X10-B04
	14.1	11.7	9.6	7.8	6.2	4.9	3.8	2.9	X10-B05
	18.8	15.6	12.8	10.3	8.2	6.5	5.0	3.8	X10-B06
	23.5	19.5	15.9	12.9	10.3	8.1	6.3	4.8	X10-B07
30 bubble/ 34.5 dew point	1.7	1.4	1.1	0.9	0.7	0.6	0.5	0.3	X10-B01
	3.5	2.9	2.4	2.0	1.6	1.2	1.0	0.7	X10-B02
	5.9	4.9	4.0	3.3	2.6	2.1	1.6	1.2	X10-B03
	9.4	7.8	6.4	5.2	4.2	3.3	2.6	2.0	X10-B04
	14.2	11.8	9.7	7.9	6.3	5.0	3.9	3.0	X10-B05
	18.9	15.7	12.9	10.5	8.4	6.7	5.2	4.0	X10-B06
	23.6	19.6	16.2	13.1	10.5	8.3	6.5	5.0	X10-B07
20 bubble/ 25.3 dew point	1.6	1.3	1.1	0.9	0.7	0.6	0.5	0.3	X10-B01
	3.4	2.8	2.3	1.9	1.5	1.2	1.0	0.7	X10-B02
	5.7	4.8	3.9	3.2	2.6	2.1	1.6	1.2	X10-B03
	9.0	7.6	6.3	5.1	4.1	3.3	2.6	2.0	X10-B04
	13.7	11.5	9.5	7.7	6.2	4.9	3.9	3.0	X10-B05
	18.2	15.2	12.6	10.3	8.3	6.6	5.2	4.0	X10-B06
	22.7	19.0	15.8	12.9	10.4	8.2	6.4	5.0	X10-B07
10 bubble/ 15.5 dew point	1.5	1.2	1.0	0.9	0.7	0.5	0.4	0.3	X10-B01
	3.1	2.6	2.2	1.8	1.5	1.2	0.9	0.7	X10-B02
	5.2	4.4	3.7	3.0	2.4	2.0	1.5	1.2	X10-B03
	8.3	7.0	5.9	4.8	3.9	3.1	2.4	1.9	X10-B04
	12.6	10.6	8.9	7.3	5.9	4.7	3.7	2.8	X10-B05
	16.8	14.2	11.8	9.7	7.8	6.3	4.9	3.8	X10-B06
	20.9	17.7	14.7	12.1	9.8	7.8	6.1	4.7	X10-B07
0 bubble/ 5.7 dew point	1.3	1.1	0.9	0.8	0.6	0.5	0.4	0.3	X10-B01
	2.7	2.3	1.9	1.6	1.3	1.1	0.8	0.6	X10-B02
	4.6	3.9	3.3	2.7	2.2	1.8	1.4	1.1	X10-B03
	7.3	6.2	5.2	4.3	3.5	2.8	2.2	1.7	X10-B04
	11.0	9.4	7.9	6.5	5.3	4.3	3.4	2.6	X10-B05
	14.6	12.5	10.5	8.7	7.1	5.7	4.5	3.5	X10-B06
	18.3	15.6	13.1	10.9	8.8	7.1	5.6	4.3	X10-B07
-10 bubble/ -4.2 dew point	1.0	0.9	0.8	0.6	0.5	0.4	0.3	0.3	X10-B01
	2.1	1.9	1.6	1.4	1.1	0.9	0.7	0.6	X10-B02
	3.6	3.2	2.7	2.3	1.9	1.5	1.2	0.9	X10-B03
	5.8	5.1	4.3	3.6	3.0	2.4	1.9	1.5	X10-B04
	8.7	7.6	6.5	5.5	4.5	3.7	2.9	2.3	X10-B05
	11.6	10.2	8.7	7.3	6.0	4.9	3.9	3.0	X10-B06
	14.4	12.7	10.9	9.1	7.5	6.1	4.8	3.8	X10-B07
-20 bubble/ -14.1 dew point	0.6	0.6	0.5	0.5	0.4	0.3	0.3	0.2	X10-B01
	1.3	1.2	1.1	1.0	0.8	0.7	0.6	0.4	X10-B02
	2.1	2.1	1.9	1.7	1.4	1.2	0.9	0.7	X10-B03
	3.4	3.3	3.1	2.7	2.3	1.9	1.5	1.2	X10-B04
	5.1	5.1	4.6	4.0	3.4	2.8	2.3	1.8	X10-B05
	6.9	6.7	6.1	5.4	4.5	3.7	3.0	2.4	X10-B06
	8.6	8.4	7.7	6.7	5.7	4.7	3.8	3.0	X10-B07
-30 bubble/ -24 dew point				0.2	0.2	0.2	0.2	0.1	X10-B01
				0.3	0.4	0.4	0.3	0.3	X10-B02
				0.6	0.7	0.6	0.5	0.4	X10-B03
				0.9	1.1	1.0	0.9	0.7	X10-B04
				1.4	1.6	1.5	1.3	1.1	X10-B05
				1.9	2.1	2.0	1.7	1.4	X10-B06
			2.3	2.7	2.5	2.2	1.8	X10-B07	

Selection Table: L-series

Valve Series	Size code*	Capacity [kW]				Cage Type	Angle flange Type / connection		Power Element
		R448A/ R449A	R450A	R513A	R1234ze		Metric	Imperial	
LCLE-	1-*	1.9	1.3	1.3	1.1	X22440-B1B	C501-5 mm	C501-5	XB1019...1B
	2-*	3.7	2.5	2.6	2.2	X22440-B2B			
	3-*	7.9	5.4	5.5	4.8	X22440-B3B			
	3.5-*	11.9	8.1	8.3	7.2	X22440-B3.5B			
	4-*	17.3	11.8	12.1	10.5	X22440-B4B	C501-7 mm	C501-7	
	6-*	22.1	15.1	15.5	13.4	X22440-B5B			
	7-*	30.3	20.7	21.2	18.4	X22440-B6B	A576-mm	A576	
	9-*	41.0	28.0	28.7	24.8	X22440-B7B			
10-*	47.7	32.6	33.4	28.9	X22440-B8B				
LJRE-	11-*	58	40	40	35	X11873-B4B	10331	10331	XC726...2B
	12-*	74	50	52	45	X11873-B5B			
LERE-	13-*	91	62	64	55	X9117-B6B	9153 mm	9153	
	14-*	104	71	73	63	X9117-B7B			
	15-*	143	98	100	86	X9117-B8B			
	16-*	174	119	121	105	X9117-B9B			
LIRE-	17-*	222	152	156	135	X9166-B10B			

Note 1: See flange table and connection sizes at the end of T-, L-, 935-, & ZZ Series chapter.

Note 2: Products are classified based on fluid group 2 (non-flammable) according European pressure equipment directive.

For selection of other operating condition, please use Controls Navigator selection program.

Valve selection for desuperheating of suction gas in conjunction with hot gas bypass

The required bypass capacity (Q_{byp} [kW]) has to be multiplied with correction factors K_{ti} per table belows:

Condensing temperature [°C]	Evaporating temperature [°C]						Condensing temperature [°C]	Evaporating temperature [°C]					
	-20	-15	-10	-5	0	5		-20	-15	-10	-5	0	5
R450A/R513A	Correction factors K _{ti}						R1234ze	Correction factors K _{ti}					
20	0.41	0.36	0.32	0.28	0.25	0.22	20	0.42	0.37	0.33	0.29	0.25	0.22
25	0.45	0.40	0.35	0.31	0.28	0.25	25	0.46	0.41	0.36	0.32	0.28	0.25
30	0.49	0.44	0.39	0.35	0.31	0.28	30	0.51	0.45	0.40	0.36	0.32	0.28
35	0.54	0.49	0.43	0.39	0.35	0.31	35	0.56	0.50	0.44	0.39	0.35	0.32
40	0.60	0.54	0.48	0.43	0.39	0.35	40	0.62	0.55	0.49	0.44	0.39	0.35
45	0.66	0.59	0.53	0.48	0.43	0.39	45	0.68	0.61	0.54	0.49	0.44	0.39
50	0.74	0.66	0.59	0.53	0.48	0.43	50	0.76	0.67	0.60	0.54	0.49	0.44

Type designation L-Series

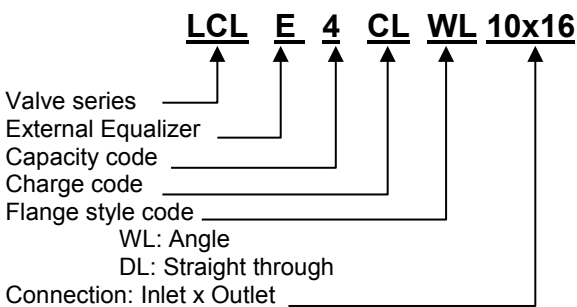

* Suction gas superheat selection

Refrigerant	Charge code *		
	CL	GL	UL
R448A	16 K	27 K	
R449A	16 K	27 K	
R450A		9 K	27 K
R513A		16 K	33 K
R1234ze			24 K

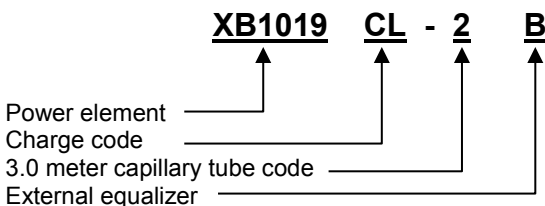

Thermo™-Expansion Valves T-, L-, 935-, ZZ-Series

Selection table: 935-series

Valve Series	Size and code	Capacity [kW]				Cage Type	Angle flange Type / connection		Power Element
		R448A/ R449A	R450A	R513A	R1234ze		Metric	Imperial	
935-*	A	5.2	3.5	3.6	3.1	X10-**01	C501-5 mm	C501-5	XB1019-***-2A
	B	10.1	6.9	7.1	6.1	X10-**02			
	C	14.2	9.7	9.9	8.6	X10-**03			
	D	21.0	14.4	14.7	12.8	X10-**04	C501-7 mm	C501-7	
	E	28.8	19.7	20.2	17.5	X10-**05			
	G	41.1	28.1	28.8	24.9	X10-**06	A576-mm	A576	
	X	59.8	40.9	41.9	36.3	X10-**07			

*) Temperature code	Temperature range [°C]	**) Spring code
3	-1...+17	B
6	+14...+38	C
7	+36...+50	A
105	+44...+70	C
106	+66...+94	C
100	+94...+121	C

***) Charge code
UL
KL
YL
YL
JL
LL

Note 1: See flange table and connection sizes at the end of T-, L-, 935-, & ZZ Series chapter.

Note 2: Products are classified based on fluid group 2 (non-flammable) according European pressure equipment directive.

For selection of other operating condition, please use quick selection tables in the next pages or Controls Navigator selection program.

Type designation 935-Series

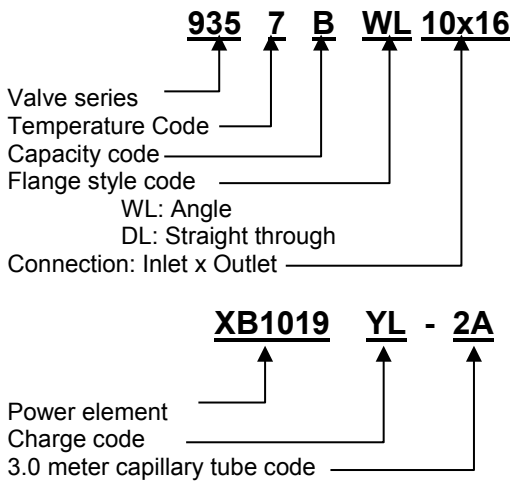

Thermo™-Expansion Valves T-, L-, 935-, ZZ-Series

935-Series: Quick selection (included 1.5 bar pressure drop for liquid line components and distributor)

Condensing temperature [°C]	R448A/R449A													Cage assembly type
	Capacity [kW]													
	Evaporating temperature [°C]													
	15	10	5	0	-5	-10	-15	-20	-25	-30	-35	-40	-45	
60 bubble/ 63.4 dew point	4.7	4.8	4.8	4.8	4.8	4.7	4.7	4.6	4.5	4.4	4.3	4.1	4.0	935-A
	9.2	9.3	9.3	9.3	9.3	9.2	9.0	8.9	8.7	8.5	8.3	8.0	7.8	935-B
	12.9	13.1	13.1	13.1	13.0	12.9	12.7	12.5	12.2	12.0	11.6	11.3	11.0	935-C
	19.2	19.4	19.5	19.5	19.4	19.2	18.9	18.6	18.2	17.8	17.3	16.8	16.3	935-D
	26.3	26.6	26.7	26.7	26.5	26.2	25.9	25.4	24.9	24.3	23.7	23.0	22.3	935-E
	37.5	37.9	38.1	38.0	37.8	37.4	36.9	36.3	35.5	34.7	33.8	32.8	31.8	935-G
	54.6	55.2	55.4	55.4	55.0	54.5	53.7	52.8	51.7	50.5	49.2	47.8	46.3	935-X
50 bubble/ 54 dew point	4.8	4.9	5.0	5.1	5.1	5.1	5.0	5.0	4.9	4.9	4.8	4.7	4.5	935-A
	9.3	9.6	9.7	9.8	9.9	9.9	9.8	9.7	9.6	9.4	9.2	9.0	8.8	935-B
	13.1	13.5	13.7	13.8	13.9	13.9	13.8	13.6	13.5	13.3	13.0	12.7	12.4	935-C
	19.5	20.0	20.3	20.5	20.6	20.6	20.5	20.3	20.0	19.7	19.3	18.9	18.5	935-D
	26.7	27.4	27.9	28.1	28.2	28.2	28.0	27.8	27.4	27.0	26.5	25.9	25.3	935-E
	38.1	39.1	39.7	40.1	40.3	40.2	40.0	39.6	39.1	38.4	37.7	36.9	36.0	935-G
	55.5	56.9	57.9	58.4	58.6	58.5	58.2	57.6	56.9	56.0	54.9	53.8	52.5	935-X
40 bubble/ 44.5 dew point	4.5	4.7	4.9	5.0	5.1	5.1	5.1	5.1	5.1	5.0	5.0	4.9	4.8	935-A
	8.7	9.2	9.5	9.7	9.9	9.9	10.0	10.0	9.9	9.8	9.7	9.5	9.4	935-B
	12.3	12.9	13.3	13.7	13.9	14.0	14.0	14.0	13.9	13.8	13.6	13.4	13.1	935-C
	18.2	19.1	19.8	20.3	20.6	20.8	20.8	20.8	20.7	20.5	20.2	19.9	19.5	935-D
	25.0	26.2	27.1	27.8	28.2	28.5	28.5	28.5	28.3	28.0	27.7	27.2	26.8	935-E
	35.6	37.4	38.7	39.6	40.2	40.6	40.7	40.6	40.4	40.0	39.5	38.8	38.1	935-G
	51.9	54.4	56.3	57.7	58.6	59.1	59.2	59.1	58.8	58.2	57.5	56.6	55.5	935-X
30 bubble/ 34.5 dew point	3.7	4.1	4.4	4.6	4.8	4.9	5.0	5.0	5.0	5.0	5.0	4.9	4.9	935-A
	7.3	8.0	8.6	9.0	9.3	9.5	9.7	9.7	9.7	9.7	9.7	9.6	9.4	935-B
	10.2	11.3	12.1	12.7	13.1	13.4	13.6	13.7	13.7	13.7	13.6	13.4	13.3	935-C
	15.2	16.8	17.9	18.8	19.4	19.9	20.2	20.3	20.4	20.3	20.2	20.0	19.7	935-D
	20.8	23.0	24.6	25.7	26.6	27.2	27.6	27.8	27.9	27.8	27.6	27.4	27.0	935-E
	29.7	32.7	35.0	36.7	37.9	38.8	39.4	39.7	39.8	39.7	39.4	39.0	38.5	935-G
	43.2	47.7	51.0	53.5	55.3	56.5	57.3	57.8	57.9	57.7	57.4	56.8	56.1	935-X
20 bubble/ 25.3 dew point		3.0	3.6	3.9	4.2	4.4	4.6	4.7	4.7	4.8	4.8	4.7	4.7	935-A
		5.9	6.9	7.6	8.2	8.6	8.8	9.0	9.2	9.2	9.2	9.2	9.1	935-B
		8.3	9.7	10.7	11.5	12.0	12.4	12.7	12.9	13.0	13.0	13.0	12.9	935-C
		12.3	14.4	15.9	17.1	17.9	18.5	18.9	19.2	19.3	19.3	19.2	19.1	935-D
		16.9	19.7	21.8	23.4	24.5	25.3	25.9	26.2	26.4	26.4	26.4	26.2	935-E
		24.0	28.2	31.1	33.3	34.9	36.1	36.9	37.4	37.7	37.7	37.6	37.3	935-G
		35.0	41.0	45.3	48.5	50.9	52.6	53.7	54.5	54.8	54.9	54.7	54.3	935-X
10 bubble/ 15.5 dew point				2.7	3.2	3.6	3.9	4.1	4.2	4.3	4.3	4.4	4.4	935-A
				5.3	6.3	7.0	7.5	7.9	8.2	8.3	8.4	8.5	8.5	935-B
				7.4	8.8	9.8	10.6	11.1	11.5	11.7	11.9	11.9	12.0	935-C
				11.0	13.1	14.6	15.7	16.5	17.0	17.4	17.6	17.8	17.8	935-D
				15.1	18.0	20.0	21.5	22.6	23.3	23.9	24.2	24.3	24.3	935-E
				21.5	25.7	28.6	30.7	32.2	33.3	34.0	34.5	34.7	34.7	935-G
				31.3	37.4	41.6	44.7	46.9	48.5	49.5	50.2	50.5	50.5	935-X

Thermo™-Expansion Valves T-, L-, 935-, ZZ-Series

935-Series: Quick selection (included 1.5 bar pressure drop for liquid line components and distributor)

Condensing temperature [°C]	R450A/R513A													Cage assembly type
	Capacity [kW]													
	Evaporating temperature [°C]													
	30	25	20	15	10	5	0	-5	-10	-15	-20	-25	-30	
80	3.3	3.3	3.3	3.2	3.2	3.1	3.0	2.9	2.8	2.4	1.9	1.5	1.1	935-A
	6.5	6.4	6.4	6.3	6.2	6.0	5.8	5.6	5.4	4.7	3.8	2.9	2.2	935-B
	9.1	9.1	9.0	8.8	8.6	8.4	8.2	7.9	7.6	6.6	5.3	4.1	3.1	935-C
	13.5	13.5	13.3	13.1	12.9	12.5	12.1	11.7	11.2	9.7	7.9	6.1	4.6	935-D
	18.5	18.5	18.3	18.0	17.6	17.1	16.6	16.0	15.4	13.3	10.8	8.3	6.3	935-E
	26.4	26.3	26.0	25.6	25.1	24.4	23.7	22.9	21.9	19.0	15.4	11.9	9.0	935-G
	38.4	38.3	37.9	37.3	36.5	35.6	34.5	33.3	32.0	27.7	22.4	17.3	13.1	935-X
70	3.4	3.5	3.5	3.5	3.5	3.4	3.4	3.3	3.2	2.8	2.3	1.8	1.4	935-A
	6.7	6.8	6.8	6.8	6.7	6.6	6.5	6.4	6.2	5.5	4.5	3.5	2.7	935-B
	9.4	9.5	9.6	9.6	9.5	9.3	9.2	9.0	8.7	7.7	6.3	4.9	3.8	935-C
	13.9	14.1	14.2	14.2	14.1	13.9	13.6	13.3	13.0	11.4	9.3	7.3	5.7	935-D
	19.1	19.4	19.5	19.4	19.3	19.0	18.7	18.2	17.8	15.6	12.8	10.0	7.7	935-E
	27.2	27.6	27.8	27.7	27.5	27.1	26.6	26.0	25.3	22.3	18.2	14.3	11.0	935-G
	39.6	40.2	40.4	40.4	40.0	39.5	38.8	37.9	36.9	32.4	26.5	20.8	16.1	935-X
60	3.2	3.4	3.5	3.5	3.5	3.5	3.5	3.5	3.4	3.0	2.5	2.0	1.5	935-A
	6.3	6.5	6.7	6.8	6.9	6.9	6.8	6.7	6.6	5.9	4.9	3.9	3.0	935-B
	8.8	9.2	9.4	9.6	9.7	9.6	9.6	9.5	9.3	8.3	6.8	5.4	4.2	935-C
	13.1	13.7	14.0	14.3	14.3	14.3	14.2	14.1	13.8	12.3	10.2	8.1	6.3	935-D
	18.0	18.7	19.2	19.5	19.6	19.6	19.5	19.3	18.9	16.8	13.9	11.0	8.6	935-E
	25.7	26.7	27.4	27.8	28.0	28.0	27.8	27.5	27.0	24.0	19.8	15.8	12.3	935-G
	37.4	38.9	39.9	40.5	40.8	40.8	40.5	40.0	39.3	34.9	28.9	22.9	17.9	935-X
50	2.7	3.0	3.1	3.3	3.4	3.4	3.5	3.5	3.4	3.1	2.6	2.1	1.6	935-A
	5.2	5.7	6.1	6.4	6.6	6.7	6.7	6.7	6.7	6.0	5.0	4.0	3.1	935-B
	7.3	8.1	8.6	9.0	9.2	9.4	9.4	9.4	9.4	8.4	7.0	5.6	4.4	935-C
	10.9	12.0	12.8	13.3	13.7	13.9	14.0	14.0	13.9	12.5	10.4	8.4	6.6	935-D
	14.9	16.4	17.5	18.3	18.8	19.1	19.2	19.2	19.1	17.1	14.3	11.4	9.0	935-E
	21.3	23.4	25.0	26.0	26.7	27.2	27.4	27.4	27.2	24.4	20.4	16.3	12.8	935-G
	31.0	34.1	36.3	37.9	39.0	39.6	39.9	39.9	39.6	35.6	29.7	23.8	18.7	935-X
40	1.5	2.1	2.5	2.8	3.0	3.1	3.2	3.3	3.3	3.0	2.5	2.0	1.6	935-A
	2.8	4.1	4.9	5.4	5.8	6.0	6.2	6.3	6.4	5.8	4.9	3.9	3.1	935-B
	4.0	5.7	6.8	7.6	8.1	8.5	8.7	8.9	9.0	8.1	6.9	5.5	4.4	935-C
	5.9	8.5	10.1	11.3	12.0	12.6	13.0	13.2	13.3	12.1	10.2	8.2	6.5	935-D
	8.1	11.7	13.9	15.4	16.5	17.3	17.8	18.1	18.2	16.5	14.0	11.3	8.9	935-E
	11.6	16.6	19.8	22.0	23.5	24.6	25.3	25.8	26.0	23.6	19.9	16.1	12.7	935-G
	16.9	24.2	28.8	32.0	34.3	35.8	36.9	37.5	37.8	34.3	29.0	23.4	18.6	935-X
30			1.1	1.8	2.2	2.5	2.7	2.8	2.9	2.7	2.3	1.9	1.5	935-A
			2.0	3.5	4.3	4.9	5.2	5.5	5.7	5.3	4.5	3.7	2.9	935-B
			2.9	4.9	6.1	6.8	7.4	7.7	8.0	7.4	6.3	5.2	4.1	935-C
			4.3	7.3	9.0	10.1	11.0	11.5	11.9	11.0	9.4	7.7	6.2	935-D
			5.8	10.0	12.3	13.9	15.0	15.8	16.3	15.1	12.9	10.5	8.4	935-E
			8.3	14.2	17.6	19.8	21.4	22.5	23.2	21.5	18.4	15.0	12.0	935-G
			12.1	20.7	25.6	28.9	31.2	32.7	33.8	31.3	26.8	21.9	17.5	935-X

Thermo™-Expansion Valves T-, L-, 935-, ZZ-Series

935-Series: Quick selection (included 1.5 bar pressure drop for liquid line components and distributor)

Condensing temperature [°C]	R1234ze													Cage assembly type
	Capacity [kW]													
	Evaporating temperature [°C]													
	30	25	20	15	10	5	0	-5	-10	-15	-20	-25	-30	
80	3.0	3.0	3.0	2.9	2.9	2.8	2.7	2.6	2.5	2.1	1.7	1.3	1.0	935-A
	5.9	5.9	5.8	5.7	5.5	5.4	5.2	5.0	4.8	4.1	3.3	2.5	1.9	935-B
	8.3	8.3	8.1	8.0	7.8	7.6	7.3	7.0	6.7	5.8	4.7	3.6	2.7	935-C
	12.3	12.3	12.1	11.9	11.6	11.2	10.8	10.4	10.0	8.6	6.9	5.3	4.0	935-D
	16.9	16.8	16.6	16.3	15.9	15.4	14.9	14.3	13.6	11.8	9.5	7.3	5.5	935-E
	24.1	24.0	23.6	23.2	22.6	21.9	21.2	20.3	19.4	16.8	13.5	10.4	7.8	935-G
	35.1	34.9	34.4	33.8	32.9	32.0	30.8	29.6	28.3	24.5	19.7	15.1	11.3	935-X
70	3.1	3.1	3.1	3.1	3.1	3.0	3.0	2.9	2.8	2.5	2.0	1.6	1.2	935-A
	6.0	6.1	6.1	6.1	6.0	5.9	5.8	5.6	5.5	4.8	3.9	3.1	2.3	935-B
	8.4	8.6	8.6	8.5	8.5	8.3	8.1	7.9	7.7	6.7	5.5	4.3	3.3	935-C
	12.6	12.7	12.8	12.7	12.6	12.4	12.1	11.8	11.4	10.0	8.2	6.4	4.9	935-D
	17.2	17.4	17.5	17.4	17.2	16.9	16.6	16.1	15.7	13.7	11.2	8.8	6.7	935-E
	24.5	24.8	24.9	24.8	24.5	24.1	23.6	23.0	22.3	19.6	16.0	12.5	9.6	935-G
	35.7	36.1	36.3	36.1	35.7	35.2	34.4	33.5	32.5	28.5	23.3	18.2	13.9	935-X
60	2.9	3.0	3.1	3.1	3.1	3.1	3.1	3.0	3.0	2.7	2.2	1.7	1.3	935-A
	5.6	5.8	6.0	6.0	6.1	6.1	6.0	5.9	5.8	5.2	4.3	3.4	2.6	935-B
	7.8	8.2	8.4	8.5	8.5	8.5	8.4	8.3	8.2	7.2	6.0	4.7	3.7	935-C
	11.6	12.1	12.5	12.6	12.7	12.7	12.5	12.4	12.1	10.8	8.9	7.0	5.4	935-D
	15.9	16.6	17.1	17.3	17.4	17.3	17.2	16.9	16.6	14.7	12.2	9.6	7.5	935-E
	22.7	23.7	24.3	24.7	24.8	24.7	24.5	24.2	23.7	21.0	17.4	13.7	10.6	935-G
	33.1	34.5	35.4	35.9	36.1	36.0	35.7	35.2	34.5	30.6	25.3	20.0	15.5	935-X
50	2.3	2.6	2.7	2.9	3.0	3.0	3.0	3.0	3.0	2.7	2.2	1.8	1.4	935-A
	4.5	5.0	5.3	5.6	5.7	5.8	5.9	5.9	5.8	5.2	4.4	3.5	2.7	935-B
	6.3	7.0	7.5	7.8	8.1	8.2	8.2	8.2	8.2	7.3	6.1	4.9	3.8	935-C
	9.3	10.4	11.1	11.6	12.0	12.2	12.3	12.2	12.1	10.9	9.1	7.3	5.7	935-D
	12.8	14.2	15.3	16.0	16.4	16.7	16.8	16.8	16.6	14.9	12.5	9.9	7.8	935-E
	18.2	20.3	21.7	22.7	23.4	23.8	23.9	23.9	23.7	21.3	17.8	14.2	11.1	935-G
	26.6	29.6	31.7	33.1	34.1	34.6	34.8	34.8	34.5	31.0	25.9	20.6	16.1	935-X
40	1.0	1.7	2.1	2.4	2.5	2.7	2.8	2.8	2.8	2.6	2.2	1.7	1.4	935-A
	1.9	3.3	4.0	4.6	4.9	5.2	5.4	5.4	5.5	5.0	4.2	3.4	2.7	935-B
	2.7	4.6	5.7	6.4	6.9	7.3	7.5	7.7	7.7	7.0	5.9	4.8	3.8	935-C
	3.9	6.8	8.5	9.6	10.3	10.8	11.2	11.4	11.5	10.4	8.8	7.1	5.6	935-D
	5.4	9.3	11.6	13.1	14.1	14.8	15.3	15.6	15.7	14.3	12.1	9.7	7.7	935-E
	7.7	13.3	16.5	18.7	20.1	21.2	21.8	22.2	22.4	20.4	17.2	13.9	10.9	935-G
	11.2	19.4	24.1	27.2	29.3	30.8	31.8	32.4	32.6	29.6	25.1	20.2	15.9	935-X
30			0.1	1.3	1.8	2.1	2.3	2.4	2.5	2.3	2.0	1.6	1.3	935-A
			0.3	2.6	3.5	4.0	4.4	4.6	4.8	4.5	3.8	3.1	2.5	935-B
			0.4	3.6	4.9	5.6	6.2	6.5	6.8	6.3	5.4	4.4	3.5	935-C
			0.5	5.4	7.2	8.4	9.2	9.7	10.1	9.3	8.0	6.6	5.2	935-D
			0.8	7.4	9.9	11.5	12.6	13.3	13.8	12.8	11.0	9.0	7.2	935-E
			1.1	10.5	14.1	16.4	17.9	19.0	19.7	18.2	15.7	12.8	10.2	935-G
			1.6	15.3	20.5	23.8	26.1	27.6	28.6	26.6	22.8	18.6	14.9	935-X
20						0.7	1.3	1.7	1.9	1.8	1.6	1.4	1.1	935-A
						1.5	2.6	3.3	3.7	3.6	3.2	2.7	2.2	935-B
						2.0	3.7	4.6	5.2	5.0	4.5	3.8	3.0	935-C
						3.0	5.5	6.8	7.7	7.5	6.7	5.6	4.5	935-D
						4.2	7.5	9.3	10.5	10.2	9.1	7.6	6.2	935-E
						5.9	10.7	13.3	14.9	14.6	13.0	10.9	8.8	935-G
						8.6	15.6	19.3	21.8	21.3	18.9	15.8	12.9	935-X

Note: Products are classified based on fluid group 2 (non-flammable) according European pressure equipment directive.

Thermo™-Expansion Valves T-, L-, 935-, ZZ-Series

Flanges: T-Series

Valve series	Orifice type	Angle style		Straight through		Connection (inlet x outlet)	
		Type	Part No.	Type	Part No.	Metric	Imperial
TCLE / LCLE	X22440-B1B / B2B/ B3B / B3.5B / B4B	C501-5	803232	9761-3	803240	-	3/8"x5/8" ODF
		C501-5mm	803233	9761-3mm	803241	10 x16 mm ODF	
	X22440-B5B / B6B	C501-7	803234	9761-4	803350		1/2"x5/8" ODF
		C501-7mm	803235	9761-4mm	803243	12 x16 mm ODF	-
	X22440-B7B / B8B	-	-	6346-17	803330	16 x22 mm ODF	5/8"x7/8" ODF
		A576	803238	-	-	-	5/8"x7/8" ODF 7/8"x1-1/8" ODM
A576-mm		803239	-	-	16 x22 mm ODF 22 x28 mm ODM	-	
TJRE / LJRE	X11873-B4B / B5B	10331	803338	10332	803324	22 x22 mm ODF	7/8"x7/8" ODF 1-1/8"x1-1/8" ODM
TERE/ TIRE LERE/ LIRE	X9117-B6B / B7B / B8B / B9B / B10B	9153	803244	9152	803286	-	7/8"x7/8" ODF 1-1/8"x1-1/8" ODM
		9153-mm	803245	9152-mm	803287	22 x22 mm ODF 22 x28 mm ODM	
THRE	X9144-B11B / B13B	9149	803284	9148	803283	22 x22 mm ODF	7/8"x7/8" ODF 1-1/8"x1-1/8" ODM

Flanges: 935- / ZZ-Series*

Valve series	Orifice type	Angle style		Straight through		Connection (inlet x outlet)	
		Type	Part No.	Type	Part No.	Metric	Imperial
935 / ZZ	X10-*01 / *02 / *03	C501-5	803232	9761-3	803240	-	3/8"x5/8" ODF
		C501-5mm	803233	9761-3mm	803241	10 x16 mm ODF	
	X10-*04 / *05	C501-7	803234	9761-4	803350		1/2"x5/8" ODF
		C501-7mm	803235	9761-4mm	803243	12 x16 mm ODF	-
	X10-*06 / *07	-	-	6346-17	803330	16 x22 mm ODF	5/8"x7/8" ODF
		A576	803238	-	-	-	5/8"x7/8" ODF 7/8"x1-1/8" ODM
A576-mm		803239	-	-	16 x22 mm ODF 22 x28 mm ODM	-	

Note:
Mandatory
for ZZ-Valves

Type Bronze Screw	Part No.	Flange types
Screw BZ 32	803575	C500, C501, 9761, X6346, X6669, A576
Screw BZ 48	803576	9148, 9149, 9152, 9153, 10331

2-Way Solenoid Valves Series

Features

- Normally closed
- Pilot operated requires minimum operating pressure differential
- Compact size
- Extended fittings: No disassembly necessary for brazing
- Coil in 24VAC/50Hz and 230VAC/50Hz available



Nominal Capacity Data

Type	Kv [m ³ /h]	ΔP_{\min} [bar]	Liquid				
			R450A	R513A	R1234ze	R448A	R449A
110RB2	0.2	0	2.6	2.7	2.3	3.8	3.7
200RB3	0.4	0.05	4.8	5.0	4.3	7.1	6.9
200RB4	0.9		11.5	11.7	10.2	16.8	16.4
200RB6	1.6		20.1	20.6	17.8	29.4	28.7
240RA8	2.3		26.8	27.4	23.8	39.2	38.3
240RA9	4.8		56.3	57.6	49.9	82.3	80.4
240RA12	5.4		63	65	56	93	90
240RA16	8.8		103	105	91	150	147
240RA20	12.8		150	153	133	219	214

Type	Kv [m ³ /h]	ΔP_{\min} [bar]	Hot gas				
			R450A	R513A	R1234ze	R448A	R449A
110RB2	0.2	0	1.4	1.5	1.3	2.0	2.0
200RB3	0.4	0.05	2.9	3.0	2.6	4.0	4.0
200RB4	0.9		6.5	6.8	5.8	9.1	9.0
200RB6	1.6		11.6	12.1	10.4	16.2	15.9
240RA8	2.3		16.6	17.3	14.9	23.2	22.9
240RA9	4.8		34.7	36.2	31.1	48.5	47.8
240RA12	5.4		39.0	40.7	35.0	54.5	53.8
240RA16	8.8		63.5	66.3	57.0	88.9	87.6
240RA20	12.8		92.4	96.4	82.9	129.3	127.5

Type	Kv [m ³ /h]	ΔP_{\min} [bar]	Suction gas				
			R450A	R513A	R1234ze	R448A	R449A
240RA8	2.3	0.05	3.7	4.0	3.4	5.1	5.0
240RA9	4.8		7.8	8.4	7.1	10.6	10.5
240RA12	5.4		8.8	9.4	8.0	11.9	11.8
240RA16	8.8		14.3	15.3	13.1	19.4	19.2
240RA20	12.8		20.8	22.3	19.0	28.3	27.9

⚠ Warning: R1234ze classified as A2L. Use of product only for non-explosive environment, non ATEX zone.

For selection of other operating condition, please use quick selection tables in the next pages or Controls Navigator selection program.

The nominal capacity is based on the following conditions:

Refrigerant	Evaporating temperature [°C]	Condensing temperature [°C]	Subcooling	Pressure Drop [bar]		
				Liquid	Hot gas	Suction
R513A, R1234ze	+4°C dew point	+38°C bubble/ +38°C dew point	1K	0.15	1	0.15
R450A		+38°C bubble/ +38.6°C dew point				
R448A, R449A		+38°C bubble/ +42.6°C dew point				

2-Way Solenoid Valves Series

Selection table valves

Function	Type		Part No.	ODF Connection	
				[mm]	[inch]
Normally closed	110 RB 2	T2	801217	6	
		T2	801210		1/4"
		T3	801209	10	
	200 RB 3	T3	801239	10	
	200 RB 4	T3	801176	10	
		T3	801190		3/8"
		T4	801178	12	
		T4	801179		1/2"
	200 RB 6	T4	801182	12	
		T4	801183		1/2"
		T5	801186	16	5/8"
	240RA 8	T5	801160		5/8"
		T7	801143	22	7/8"
	240 RA 9	T5	801161	16	5/8"
		T7	801162	22	7/8"
		T9	801142		1-1/8"
	240 RA 12	T7	801163	22	7/8"
		T9	801144		1-1/8"
	240 RA 16	T9	801164		1-1/8"
		T11	801166	35	1-3/8"
240 RA 20	T11-M	801172	35	1-3/8"	
	T13-M	801224	42		
	T13-M	801173		1-5/8"	
	T17-M	801174	54	2-1/8"	
Normally open	540 RA8	T5	046265		5/8"
	540 RA 9	T5	046266		5/8"
		T7	046268	22	7/8"
	540 RA 12	T7	046269	22	7/8"
	540 RA 16	T9	046270		1-1/8"
	540 RA 20	T11	047953	35	1-3/8"

Note: Manual stems (Type M) available upon request for selected 2 types of Series 240 RA 8 to 240 RA 16.
Manual stems standard on Series 240 RA 20.

Selection table coils

Type	Part No.
ASC3-24VAC, 50 Hz	801079
ASC3-230VAC, 50 Hz	801077
ASC3-24VDC	801076

Technical data valve

Max. allowable working pressure PS	31 bar
Test pressure PT	34.1 bar
Operating Temperature Range TS	-40°C...+120°C
Ambient temperature range	-40°C...+50°C

Technical data coils

Supply voltage ASC3-24VAC ASC3-230VAC	24 VAC ±10% 230 VAC ±10%
Frequency	50 Hz
Protection Class	IP65
Marking (only coil)	CE, EAC, cRU ^{us}

Accessories and spare parts for solenoid valves

Description	Type	Part No.
Service tool for 110 RB, 240 RA, 540 RA	X 11981-1	027451
Gasket kits	KS 30040-2	801232
Repairing Kit 110 RB/RA	KS 30039-1	801233
Repairing Kit 240 RA8	KS 30061-1	801234
Repairing Kit 240 RA 9/12	KS 30062-1	801235
Repairing Kit 240 RA 16	KS 30065-1	801236
Repairing Kit 240RA 20	KS 30097-1	801237

Description	Type	Part No.
Repairing Kit 110 RB/RA	KS 30040-1	801206
Repairing Kit 200 RB/RA	KS 30039/ KS 30109	801205
Repairing Kit 240 RA 8	KS 30061	801262
Repairing Kit 240 RA 9	KS 30062	801263
Repairing Kit 240 RA 12	KS 30063	801264
Repairing Kit 240 RA 16	KS 30065	801200
Repairing Kit 240 RA 20	KS 30097	801216

2-Way Solenoid Valves Series

Liquid line solenoid valve: Quick selection (at 0.15 bar pressure drop)

Condensing temperature [°C]	R448A/R449A												Solenoid Valve type
	Capacity [kW]												
	Evaporating temperature [°C]												
	15	10	5	0	-5	-10	-15	-20	-25	-30	-35	-40	
60 bubble/ 63.4 dew point	3.6	3.6	3.6	3.6	3.6	3.5	3.5	3.4	3.4	3.3	3.2	3.1	110RB2
	6.7	6.7	6.8	6.7	6.7	6.6	6.5	6.4	6.3	6.1	6.0	5.8	200RB3
	15.8	16.0	16.0	16.0	15.9	15.7	15.5	15.2	14.9	14.5	14.1	13.7	200RB4
	27.8	28.0	28.1	28.0	27.8	27.5	27.1	26.7	26.1	25.5	24.8	24.1	200RB6
	37.0	37.3	37.4	37.3	37.1	36.7	36.1	35.5	34.8	33.9	33.0	32.1	240RA8
	77.7	78.3	78.6	78.4	77.8	77.0	75.9	74.5	73.0	71.3	69.4	67.4	240RA9
	87.3	88.1	88.4	88.2	87.6	86.6	85.4	83.8	82.1	80.2	78.0	75.8	240RA12
	142	143	143	143	142	140	138	136	133	130	127	123	240RA16
206	208	209	208	207	205	202	198	194	189	184	179	240RA20	
50 bubble/ 54 dew point	3.7	3.8	3.8	3.8	3.9	3.8	3.8	3.8	3.7	3.7	3.6	3.5	110RB2
	6.9	7.0	7.1	7.2	7.2	7.2	7.1	7.1	7.0	6.8	6.7	6.6	200RB3
	16.3	16.6	16.9	17.0	17.0	17.0	16.9	16.7	16.5	16.2	15.9	15.5	200RB4
	28.6	29.2	29.6	29.8	29.9	29.8	29.6	29.3	28.9	28.4	27.9	27.3	200RB6
	38.1	38.9	39.5	39.8	39.8	39.7	39.5	39.0	38.5	37.9	37.1	36.3	240RA8
	80.0	81.7	82.9	83.5	83.6	83.4	82.8	82.0	80.8	79.5	78.0	76.3	240RA9
	90.0	91.9	93.2	93.9	94.1	93.8	93.2	92.2	90.9	89.4	87.7	85.8	240RA12
	146	149	151	152	153	152	151	150	147	145	142	139	240RA16
213	217	220	222	222	222	220	218	215	211	207	203	240RA20	
40 bubble/ 44.5 dew point	3.5	3.7	3.8	3.9	3.9	3.9	3.9	3.9	3.9	3.8	3.8	3.7	110RB2
	6.6	6.9	7.1	7.2	7.3	7.3	7.3	7.3	7.3	7.2	7.1	7.0	200RB3
	15.6	16.2	16.7	17.0	17.2	17.3	17.4	17.3	17.2	17.0	16.8	16.5	200RB4
	27.4	28.5	29.3	29.9	30.3	30.5	30.5	30.4	30.2	29.8	29.4	29.0	200RB6
	36.5	38.0	39.1	39.8	40.3	40.6	40.6	40.5	40.2	39.8	39.2	38.6	240RA8
	76.6	79.7	82.0	83.7	84.7	85.2	85.3	85.0	84.3	83.4	82.3	81.0	240RA9
	86.1	89.7	92.3	94.1	95.2	95.8	95.9	95.6	94.9	93.9	92.6	91.1	240RA12
	140	145	150	153	154	155	156	155	154	152	150	148	240RA16
204	212	218	222	225	226	227	226	224	222	219	215	240RA20	
30 bubble/ 33.5 dew point	3.1	3.3	3.5	3.7	3.8	3.8	3.9	3.9	3.9	3.9	3.8	3.8	110RB2
	5.8	6.2	6.6	6.8	7.0	7.2	7.2	7.3	7.3	7.2	7.2	7.1	200RB3
	13.7	14.8	15.6	16.2	16.6	16.9	17.1	17.2	17.2	17.1	17.0	16.8	200RB4
	24.1	26.0	27.4	28.4	29.2	29.7	30.0	30.2	30.2	30.0	29.8	29.5	200RB6
	32.1	34.6	36.5	37.9	38.9	39.6	40.0	40.2	40.2	40.0	39.7	39.2	240RA8
	67.3	72.6	76.6	79.5	81.6	83.1	84.0	84.3	84.3	84.0	83.3	82.4	240RA9
	75.7	81.7	86.1	89.4	91.8	93.5	94.4	94.9	94.9	94.4	93.7	92.7	240RA12
	123	132	140	145	149	152	153	154	154	153	152	150	240RA16
179	193	204	211	217	221	223	224	224	223	221	219	240RA20	
20 bubble/ 25.3 dew point		2.7	3.0	3.3	3.4	3.6	3.7	3.7	3.7	3.8	3.7	3.7	110RB2
		5.1	5.7	6.1	6.4	6.7	6.8	6.9	7.0	7.0	7.0	7.0	200RB3
		12.1	13.5	14.5	15.2	15.8	16.1	16.4	16.5	16.6	16.6	16.5	200RB4
		21.3	23.6	25.4	26.7	27.7	28.3	28.8	29.0	29.1	29.1	28.9	200RB6
		28.3	31.5	33.8	35.6	36.9	37.8	38.4	38.7	38.8	38.8	38.5	240RA8
		59.4	66.1	71.0	74.7	77.4	79.3	80.5	81.2	81.5	81.4	80.9	240RA9
		66.9	74.3	79.9	84.0	87.0	89.2	90.6	91.4	91.7	91.5	91.0	240RA12
		108	121	130	136	141	145	147	148	149	148	148	240RA16
	158	176	189	199	206	211	214	216	217	216	215	240RA20	
10 bubble/ 15.5 dew point				2.6	2.9	3.1	3.3	3.4	3.5	3.5	3.5	3.5	110RB2
				4.9	5.5	5.8	6.1	6.3	6.5	6.6	6.6	6.6	200RB3
				11.6	12.9	13.8	14.5	15.0	15.3	15.5	15.6	15.7	200RB4
				20.5	22.7	24.3	25.5	26.3	26.9	27.3	27.5	27.5	200RB6
				27.2	30.2	32.3	33.9	35.1	35.9	36.3	36.6	36.7	240RA8
				57.2	63.4	67.9	71.2	73.6	75.3	76.3	76.8	77.0	240RA9
				64.3	71.3	76.4	80.1	82.8	84.7	85.8	86.4	86.6	240RA12
				104	116	124	130	134	137	139	140	140	240RA16
			152	168	180	189	196	200	203	204	205	240RA20	

2-Way Solenoid Valves Series

Liquid line solenoid valve: Quick selection (at 0.15 bar pressure drop)

Condensing temperature [°C]	R450A/R513A										Solenoid Valve type
	Capacity [kW]										
	Evaporating temperature [°C]										
	15	10	5	0	-5	-10	-15	-20	-25	-30	
70	2.7	2.7	2.6	2.6	2.5	2.4	2.4	2.3	2.2	2.1	110RB2
	5.0	5.0	4.9	4.8	4.7	4.5	4.4	4.3	4.1	3.9	200RB3
	11.9	11.8	11.6	11.3	11.1	10.8	10.4	10.1	9.7	9.3	200RB4
	20.8	20.6	20.3	19.9	19.4	18.9	18.3	17.7	17.0	16.3	200RB6
	27.8	27.5	27.1	26.5	25.9	25.2	24.4	23.5	22.6	21.7	240RA8
	58.3	57.7	56.8	55.7	54.4	52.8	51.2	49.4	47.5	45.5	240RA9
	65.6	64.9	63.9	62.6	61.1	59.4	57.6	55.6	53.4	51.2	240RA12
	106	105	104	102	99	96	93	90	87	83	240RA16
	155	153	151	148	145	140	136	131	126	121	240RA20
60	2.7	2.8	2.7	2.7	2.7	2.6	2.6	2.5	2.4	2.4	110RB2
	5.1	5.1	5.1	5.1	5.0	4.9	4.8	4.7	4.6	4.4	200RB3
	12.2	12.2	12.1	12.0	11.8	11.6	11.4	11.1	10.8	10.4	200RB4
	21.3	21.4	21.3	21.1	20.8	20.4	20.0	19.5	18.9	18.3	200RB6
	28.4	28.5	28.4	28.1	27.7	27.2	26.6	25.9	25.2	24.4	240RA8
	59.7	59.8	59.6	59.0	58.2	57.1	55.9	54.4	52.9	51.2	240RA9
	67.1	67.3	67.0	66.4	65.4	64.3	62.8	61.2	59.5	57.6	240RA12
	109	109	109	108	106	104	102	99	96	93	240RA16
	159	159	158	157	155	152	148	145	141	136	240RA20
50	2.7	2.7	2.7	2.7	2.7	2.7	2.7	2.6	2.6	2.5	110RB2
	5.0	5.1	5.1	5.1	5.1	5.1	5.0	4.9	4.8	4.7	200RB3
	11.8	12.0	12.1	12.1	12.1	12.0	11.8	11.6	11.3	11.1	200RB4
	20.6	21.0	21.2	21.3	21.2	21.0	20.7	20.3	19.9	19.4	200RB6
	27.5	28.0	28.3	28.3	28.2	28.0	27.6	27.1	26.5	25.9	240RA8
	57.7	58.8	59.3	59.5	59.2	58.7	57.9	56.9	55.7	54.4	240RA9
	64.9	66.1	66.7	66.9	66.6	66.0	65.1	64.0	62.7	61.2	240RA12
	105	107	108	108	108	107	106	104	102	99	240RA16
	153	156	158	158	157	156	154	151	148	145	240RA20
40	2.4	2.5	2.6	2.6	2.7	2.7	2.7	2.6	2.6	2.5	110RB2
	4.5	4.7	4.8	4.9	5.0	5.0	5.0	4.9	4.8	4.8	200RB3
	10.6	11.1	11.4	11.6	11.7	11.8	11.7	11.6	11.5	11.3	200RB4
	18.7	19.5	20.1	20.4	20.6	20.7	20.6	20.4	20.1	19.8	200RB6
	24.9	26.0	26.8	27.2	27.5	27.5	27.4	27.2	26.8	26.4	240RA8
	52.3	54.6	56.2	57.2	57.7	57.8	57.5	57.0	56.3	55.3	240RA9
	58.8	61.4	63.2	64.3	64.9	65.0	64.7	64.1	63.3	62.2	240RA12
	95	100	103	104	105	105	105	104	103	101	240RA16
	139	145	149	152	153	154	153	152	150	147	240RA20
30		2.2	2.3	2.4	2.5	2.5	2.5	2.5	2.5	2.5	110RB2
		4.0	4.3	4.5	4.6	4.7	4.7	4.7	4.7	4.7	200RB3
		9.5	10.2	10.6	10.9	11.1	11.2	11.2	11.1	11.0	200RB4
		16.8	17.9	18.7	19.2	19.5	19.6	19.7	19.6	19.4	200RB6
		22.3	23.8	24.8	25.5	26.0	26.2	26.2	26.1	25.8	240RA8
		46.9	50.0	52.2	53.6	54.5	54.9	55.0	54.7	54.2	240RA9
		52.8	56.2	58.7	60.3	61.3	61.8	61.9	61.6	61.0	240RA12
		86	91	95	98	99	100	100	100	99	240RA16
		125	133	139	143	145	146	146	146	144	240RA20
20				2.0	2.2	2.3	2.3	2.3	2.4	2.4	110RB2
				3.8	4.0	4.2	4.3	4.4	4.4	4.4	200RB3
				9.0	9.5	9.9	10.2	10.4	10.4	10.4	200RB4
				15.7	16.8	17.5	17.9	18.2	18.3	18.3	200RB6
				21.0	22.3	23.3	23.9	24.3	24.4	24.4	240RA8
				44.0	46.9	48.9	50.2	50.9	51.3	51.3	240RA9
				49.5	52.7	55.0	56.4	57.3	57.7	57.7	240RA12
				80	86	89	92	93	94	94	240RA16
				117	125	130	133	135	136	136	240RA20

2-Way Solenoid Valves Series

Liquid line solenoid valve: Quick selection (at 0.15 bar pressure drop)

Condensing temperature °C]	R1234ze										Solenoid Valve type
	Capacity [kW]										
	Evaporating temperature [°C]										
	15	10	5	0	-5	-10	-15	-20	-25	-30	
70	2,4	2,4	2,3	2,3	2,2	2,2	2,1	2,0	1,9	1,8	110RB2
	4,5	4,5	4,4	4,3	4,2	4,0	3,9	3,7	3,6	3,4	200RB3
	10,7	10,6	10,4	10,1	9,9	9,6	9,2	8,9	8,5	8,1	200RB4
	18,8	18,6	18,2	17,8	17,3	16,8	16,2	15,6	14,9	14,2	200RB6
	25,1	24,7	24,3	23,7	23,1	22,4	21,6	20,7	19,8	18,9	240RA8
	52,7	52,0	51,0	49,8	48,5	46,9	45,3	43,5	41,6	39,7	240RA9
	59,2	58,4	57,4	56,0	54,5	52,8	50,9	48,9	46,8	44,6	240RA12
	96	95	93	91	88	86	83	79	76	72	240RA16
	140	138	136	132	129	125	120	116	111	105	240RA20
60	2,5	2,5	2,5	2,4	2,4	2,3	2,3	2,2	2,1	2,1	110RB2
	4,6	4,6	4,6	4,5	4,4	4,4	4,2	4,1	4,0	3,9	200RB3
	10,9	10,9	10,8	10,7	10,5	10,3	10,0	9,8	9,4	9,1	200RB4
	19,2	19,2	19,0	18,8	18,5	18,1	17,6	17,1	16,6	16,0	200RB6
	25,5	25,5	25,4	25,1	24,6	24,1	23,5	22,8	22,1	21,3	240RA8
	53,6	53,6	53,2	52,6	51,7	50,6	49,3	47,9	46,4	44,7	240RA9
	60,3	60,3	59,9	59,2	58,2	56,9	55,5	53,9	52,2	50,3	240RA12
	98	98	97	96	94	92	90	87	85	82	240RA16
	142	142	142	140	137	135	131	127	123	119	240RA20
50	2,4	2,4	2,4	2,4	2,4	2,4	2,4	2,3	2,2	2,2	110RB2
	4,4	4,5	4,5	4,5	4,5	4,5	4,4	4,3	4,2	4,1	200RB3
	10,5	10,7	10,8	10,8	10,7	10,6	10,4	10,2	9,9	9,7	200RB4
	18,4	18,7	18,9	18,9	18,8	18,5	18,2	17,9	17,5	17,0	200RB6
	24,6	25,0	25,1	25,1	25,0	24,7	24,3	23,8	23,3	22,6	240RA8
	51,5	52,4	52,8	52,8	52,5	51,9	51,0	50,0	48,8	47,5	240RA9
	58,0	58,9	59,4	59,4	59,0	58,3	57,4	56,3	54,9	53,5	240RA12
	94	96	96	96	96	95	93	91	89	87	240RA16
	137	139	140	140	139	138	136	133	130	126	240RA20
40	2,1	2,2	2,3	2,3	2,3	2,3	2,3	2,3	2,3	2,2	110RB2
	4,0	4,2	4,3	4,4	4,4	4,4	4,4	4,3	4,2	4,2	200RB3
	9,4	9,9	10,1	10,3	10,4	10,4	10,3	10,2	10,0	9,8	200RB4
	16,6	17,3	17,8	18,1	18,2	18,2	18,1	17,9	17,6	17,3	200RB6
	22,1	23,1	23,7	24,1	24,3	24,3	24,1	23,8	23,5	23,0	240RA8
	46,3	48,4	49,8	50,6	50,9	50,9	50,6	50,0	49,3	48,3	240RA9
	52,1	54,4	56,0	56,9	57,3	57,3	56,9	56,3	55,4	54,3	240RA12
	85	88	91	92	93	93	92	91	90	88	240RA16
	123	129	132	134	135	135	135	133	131	128	240RA20
30		1,9	2,0	2,1	2,2	2,2	2,2	2,2	2,2	2,2	110RB2
		3,5	3,8	3,9	4,1	4,1	4,1	4,1	4,1	4,1	200RB3
		8,4	9,0	9,3	9,6	9,7	9,8	9,8	9,7	9,6	200RB4
		14,7	15,7	16,4	16,9	17,1	17,2	17,2	17,1	16,9	200RB6
		19,6	20,9	21,9	22,5	22,8	23,0	22,9	22,8	22,5	240RA8
		41,2	44,0	45,9	47,1	47,9	48,2	48,2	47,8	47,3	240RA9
		46,3	49,4	51,6	53,0	53,9	54,2	54,2	53,8	53,2	240RA12
		75	80	84	86	87	88	88	87	86	240RA16
		109	117	122	125	127	128	128	127	126	240RA20
20				1,8	1,9	2,0	2,0	2,0	2,1	2,1	110RB2
				3,3	3,5	3,7	3,8	3,8	3,8	3,8	200RB3
				7,8	8,3	8,7	8,9	9,1	9,1	9,1	200RB4
				13,7	14,6	15,3	15,7	15,9	16,0	16,0	200RB6
				18,3	19,5	20,3	20,9	21,2	21,3	21,3	240RA8
				38,4	40,9	42,7	43,8	44,5	44,7	44,7	240RA9
				43,1	46,1	48,0	49,3	50,0	50,3	50,2	240RA12
				70	75	78	80	81	82	81	240RA16
				102	109	113	117	118	119	119	240RA20

⚠ Warning: R1234ze classified as A2L. Use of product only for non-explosive environment, non ATEX zone.

3-Way Solenoid Valves Series M36

Features

- For heat reclaim application
- Pilot connection to suction line. No need for minimum pressure differential
- Compact size
- Snap-on clip for attaching solenoid coils
- No disassembly necessary for brazing
- Max. allowable pressure PS: 35 bar

Accessories

- ASC3 Coils and Cable assemblies conform to Low Voltage Directive



M36-118 + ASC3

Selection table and Capacity Data

Type	Part No.	Connection Solder/ODF		Nominal Capacity Q _n [kW]					k _v -value [m ³ /h]	Coil Type
		[mm]	[inch]	R448A	R449A	R450A	R513A	R1234ze		
M36-078	801420	22	7/8"	31.3	31.3	28.9	28.9	28.9	6.7	ASC3
M36-118	801421		1-1/8"							

The nominal capacity is based on the following conditions:

Refrigerant	Evaporating temperature	Condensing temperature	Subcooling	Pressure Drop Liquid
R513A, R1234ze	+4°C dew point	+38°C bubble/ +38°C dew point	1K	0.15 bar
R450A		+38°C bubble/ +38.6°C dew point		
R448A, R449A		+38°C bubble/ +42.6°C dew point		

⚠ Warning: R1234ze classified as A2L. Use of product only for non-explosive environment, non ATEX zone.

For selection of other operating condition, please use Controls Navigator selection program.

Selection table coils

Type	Part No.
ASC3-24VAC, 50 Hz	801079
ASC3-230VAC, 50 Hz	801077
ASC3-24VDC	801076

Accessories and spare parts

Description	Part No.
Repair Kit for M36-UNF (O-Ring Gasket & pilot assembly)	801440

ACP / CPHE - Hot Gas Bypass Regulators

Features

- High quality materials and processes for high reliability and long lifetime

ACP

- Internal equalization
- Compact size

CPHE

- Superior partial load performance due to double seat orifice design (CPHE3 to CPHE6)
- Modular design for economical logistics and easy assembly and servicing
- External equalization
- Specific connection sizes and flanges available on request

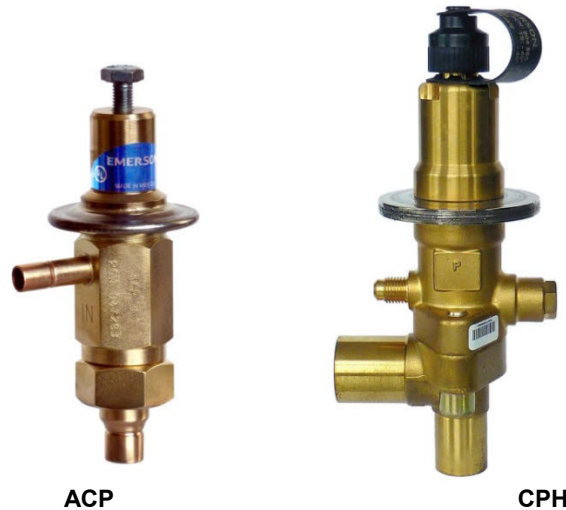

ACP

CPHE

Selection tables

Type	Nominal Bypass Capacity Q_n [kW]					Orifice	Standard Flange Solder/ODF		Power Assembly
	R450A	R513A	R1234ze	R448A	R449A		[mm]	[inch]	
CPHE-1X	3.4	2.6	5.9	5.8	3.1	X 22440-B5B	C 501 - 7mm 12 x 16	C 501 - 7 1/2 x 5/8	X7818 - 1
CPHE-2X	6.2	4.8	10.6	10.5	5.6	X 22440-B8B	A 576mm 16 x 22 (22 x 28 ODM)	A 576 5/8 x 7/8 (7/8 x 1-1/8 ODM)	
CPHE-3X	12	9	20	20	10	X 11873-B5B	10331 22 x 22	10331 7/8 x 7/8 (1-1/8 x 1-1/8 ODM)	
CPHE-3,5X	13	10	22	22	12	X 9117-B7B	9153mm 22 x 22	9153 7/8 x 7/8	
CPHE-4X	16	12	27	26	14	X 9117-B9B			
CPHE-5X	20	15	35	34	18	X 9166-B10B			
CPHE-6X	34	26	59	58	31	X 9144-B13B	9149 22 x 22	9149 7/8 x 7/8	

Note 1: Nominal capacities at 38°C condensing temperature, +4°C evaporating temperature (saturated temperatures / dew point) and 1K liquid subcooling at inlet of the expansion valve.

Note 2: Products are classified based on fluid group 2 (non-flammable) according European pressure equipment directive.

Type	Part No.	Connection, Angle Solder/ODF [inch]	Nominal Bypass Capacity Q_n [kW]				
			R450A	R513A	R1234ze	R448A	R449A
ACP 1	047680	1/4 x 3/8	0.2	0.2	0.2	0.4	0.4
ACP 3	047283	1/4 x 3/8	0.5	0.5	0.4	0.9	0.9
ACP 5	053374	3/8 x 3/8	1.1	1.2	0.9	2.1	2.0

Note: Nominal capacities at 38°C Condensing temperature. +4°C evaporating temperature (saturated temperatures 7 dew point) and 1K liquid subcooling at inlet of the expansion valve.

The nominal capacity is based on the following conditions:

Refrigerant	Evaporating temperature [°C]	Condensing temperature [°C]	Subcooling
R513A, R1234ze	+4°C dew point	+38°C bubble/ +38°C dew point	1K
R450A		+38°C bubble/ +38.6°C dew point	
R448A, R449A		+38°C bubble/ +42.6°C dew point	

Features

- Max. working pressure PS 46 bar
- Self-contained unit with oil level sensor and integral solenoid to manage oil level supply
- 3 Zone Level Control by using precise Hall-Sensor measurement, not prone to errors by foaming or light like optical sensors
- Alarm, status and level indication by LED's
- Supply 24VAC or 230VAC
- SPDT output contact for compressor shut down or alarming, rating 230VAC / 3A
- Easy installation by sight-glass replacement and front side mounting without nuts
- Adapters suitable for various types of compressors
- Recommended by leading compressor manufacturers
- **CE** marking under Low Voltage and EMC Directive, **EAC**

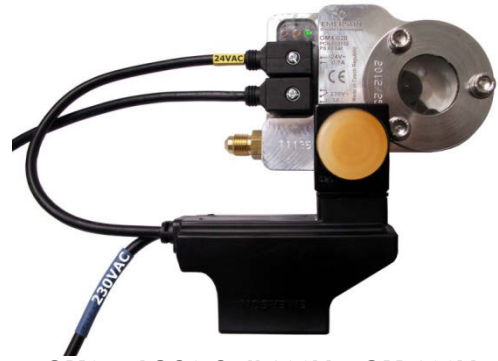

OM3 + ASC3 Coil 230V + OM-230V

Product Selection OM3 (select one item of each group)

1. Base Units (supplied without adapter and coil)

Type	Part No.	Max. working pressure PS	Time delay alarm
OM3-020	805133	46 bar	20 sec
OM3-120	805134		120 sec

2. Adapter Flanges

OM0-CUA	805037	Flange adapter 3- / 4-hole
OM0-CCC	805041	Flange adapter 3-hole
OM0-CBB	805038	Screw adapter 1-1/8"-18 UNEF
OM0-CCA	805039	Screw adapter 3/4"-14 NPTF
OM0-CCB	805040	Screw adapter 1-1/8"-12 UNF
OM0-CCD	805042	Rotalock adapter 1-3/4"-12UNF
OM0-CCE	805043	Rotalock adapter 1-1/4"-12UNF

3. Cables Alarm Relay

OM3-N30	805141	Connection to Relay 3 m
OM3-N60	805142	Connection to Relay 6 m
OM3-N100	805146	Connection to Relay 10 m



Supply voltage 24V ±10%

4. Solenoid Coil

Type	Part No.	
ASC3 24 VAC	801079	50 Hz, 17 VA

5. Cable Assembly Power Supply and Solenoid

OM3-P30	805151	24V, 3 m
OM3-P60	805152	24V, 6 m
OM3-P100	805153	24V, 10 m

Supply voltage 230V ±10%

4. Solenoid Coil

Type	Part No.	
ASC3 230 VAC	801077	50 Hz, 17 VA

5. Cable Assembly with 230V module

OM-230V-3	805163	230V, 3 m
OM-230V-6	805164	230V, 6 m

⚠ Warning: R1234ze classified as A2L. Use of product only for non-explosive environment, non ATEX zone.



Oil Management Kits including Adapter and 24V Coil: Cross Reference

Kits incl. Adapter	Part No.	Base Unit	Part No.	Adapter	Part No.	Coil	Part No.
OM3-CUA	805030	OM3-020	805133	OM0-CUA	805037	ASC3 24 VAC	801079
OM3-CBB	805032			OM0-CBB	805038		
OM3-CCA	805033			OM0-CCA	805039		
OM3-CCB	805034			OM0-CCB	805040		
OM3-CCC	805035			OM0-CCC	805041		
OM3-CCD	805031			OM0-CCD	805042		
OM3-CCE	805029			OM0-CCE	805043		

Accessories and Spare Parts

Type	Part No.	Description	Weight
ECT-623	804421	Transformer 230 VAC / 24VAC, 60 VA (supply of 3 pieces Base unit)	1.20 kg
ASC3-K01	801080	Retainer Kit ASC3 incl. O-rings	0.10 kg
ODP-33A	800366	Differential Oil Check Valve 3.5 bar, PS: 46 bar (Inlet 5/8"-UNF female, outlet 5/8"-UNF male)	0.14 kg
OM3-K01	805036	Repair Kit OM3/OM4 (consists of sight glass with O-ring and screws, oil adapter with strainer, O-ring back side)	0.26 kg
OM-HFC-K01	805081	Sealing Kit OM3/OM4 (consists of all O-rings for OM3/OM4 and for all types of adapters)	
OM-HFC-K02	805083	Enclosing tube for OM3/OM4 (including O-ring), only for replacement of new version with hexagonal nut!	

Technical Data

Markings:	 under: - Low Voltage Directive 2006/95/EC - EMC Directive 89/336/EC 	Materials:	Body and Adapter: aluminum (EN AW 6060) Screws: galvanized steel Sight Glass: nickel-plated steel (ISO 2081)
Applied Standards:	EN 12284, EN 378, EN 61010, EN 50081-1, EN 50082-1	Flow rate	OM3 at ΔP =3 bar: 340g/min. (22°C oil temperature, oil type HM46)
Max. working pressure PS: Max. Test pressure PT:	46 bar 51 bar	Orientation of base unit: Level control:	Horizontal, +/- 1° 40% to 60% of sight glass height
Supply voltage / total power: • with ASC3-24VAC coil • with ASC3-230VAC coil and OM-230V-x module	24VAC, 50/60 Hz, ±10%, 17VA 230VAC, 50/60 Hz, ±10%, 17VA	Weight: 24V System 230V System	750 ... 920 g incl. adapter 1100 ... 1270 g incl. adapter
Solenoid valve MOPD	30 bar	Alarm contact:	max. 3A, 230VAC, SPDT dry contact
Vibration resistance (EN60068-2-6)	max. 4g, 10...250 Hz	Time Delay Alarm:	20 sec.: OM3-020, all OM3 Kits 120 sec.: OM3-120
Medium temperature Ambient/Storage temp.	-20...+80°C -20...+50°C	Time Delay Filling:	10 sec.
Protection class	IP 65 (IEC529/EN 60529)	Oil connection	7/16"-20 UNF male, with strainer and O-ring (replaceable, see acc.)
		Enclosing tube	Replaceable for cleaning, hexagon wrench size 18, see spare parts

OW4 TraxOil are intended for systems which require oil level monitoring and alarming instead of active oil level balancing like OM3/4/5 series.

Features

- Max. working pressure PS: 60 bar
- 3 Zone Level Control by using precise Hall-sensor measurement, not prone to errors by foaming or light like optical sensors
- Alarm, status and 3 zone indication by LED's
- SPDT output contact for compressor shut down or alarming, rating (230VAC / 3A)
- Easy installation by sight-glass replacement and front side mounting without nuts
- Supply 24V AC, 50/60Hz
- Adapters suitable for various types of compressors
- Recommended by leading compressor manufacturers
- **CE** marking under Low Voltage and EMC Directive, **EAC**



OW4 TraxOil

Product Selection OW4 (select one item of each group)

1. Base Units

Type	Part No.	Max. working pressure PS	Time delay alarm
OW4-020	805116	60 bar	20 sec

2. Adapter flanges

OM0-CUA	805037	Flange adapter 3- / 4-hole
OM0-CCC	805041	Flange adapter 3-hole
OM0-CBB	805038	Screw adapter 1-1/8"-18 UNEF
OM0-CCA	805039	Screw adapter 3/4"-14 NPTF
OM0-CCB	805040	Screw adapter 1-1/8"-12 UNF
OM0-CCD	805042	Rotalock adapter 1-3/4"-12UNF
OM0-CCE	805043	Rotalock adapter 1-1/4"-12UNF

3. Cables Alarm Relay

OM3-N30	805141	Connection to Relay 3 m
OM3-N60	805142	Connection to Relay 6 m
OM3-N100	805146	Connection to Relay 10 m

4. Cable Power Supply

OW-24V-3	804672	Connection to Power Supply 24VAC 3 m
----------	--------	--------------------------------------

Accessories and Spare Parts

Type	Part No.	Description	Weight
ECT-623	804421	Transformer 230VAC / 24VAC, 60VA	1.20 kg
OM-HFC-K01	805081	Sealing Kit OW4 (consists of all O-rings, incl. adapter gaskets)	

⚠ Warning: R1234ze classified as A2L. Use of product only for non-explosive environment, non ATEX zone.

Technical Data

Max. working pressure PS:	OW4: 60 bar
Max. test pressure PT:	OW4: 66 bar
Burst Pressure:	OW4: 230 bar
Applied Standards:	EN 12284, EN 378, EN 61010, EN 50081-1, EN 50082-1
Supply voltage / current	24VAC, 50 Hz, ±10%, 0.05A
Vibration resistance (EN60068-2-6)	max. 4g, 10...250Hz

Medium temperature	-20...+80°C
Ambient/Storage temperature	-20...+50°C
Alarm contact:	max. 3A, 230VAC SPDT dry contact
Time Delay Alarm:	20 sec or 120 sec
Protection class	IP65 (IEC529/EN 60529)
Weight	850...920g incl. adapter

LW4 Liquid Level Monitoring Systems

LW4 are self-contained units intended for liquid level monitoring at the sight glass connection of vessels, maintaining a permanent visibility of the liquid level versus other liquid level sensors.

Features

- Two Versions of each model:
 - LW4-H for high liquid level monitoring
 - LW4-L for low liquid level monitoring
- 3 Zone Level Control by using precise Hall-sensor measurement, not prone to errors by foaming or light like optical sensors
- Alarm, status and 3 zone indication by LED's
- Two independent output signals:
 1. 24V output signal for critical levels and actuator activation
 2. SPDT output contact for alarming (230VAC / 3A) at very low liquid levels
- Easy installation by sight-glass replacement and front side mounting without nuts
- Supply 24V AC, 50/60Hz
- Adapters suitable for various types of vessels
- **CE** marking under Low Voltage and EMC Directive, **ERC**



Product Selection LW4 (select one item of each group)

1. Base Units

Type	Part No.	Max. working pressure
LW4-H120	805491	60 bar
LW4-L120	805490	60 bar

2. Adapter flanges

OM0-CUA	805037	Flange adapter 3- / 4-hole
OM0-CCC	805041	Flange adapter 3-hole
OM0-CBB	805038	Screw adapter 1-1/8"-18 UNEF
OM0-CCA	805039	Screw adapter 3/4"-14 NPTF
OM0-CCB	805040	Screw adapter 1-1/8"-12 UNF
OM0-CCD	805042	Rotalock adapter 1-3/4"-12UNF
OM0-CCE	805043	Rotalock adapter 1-1/4"-12UNF

3. Cables Alarm Relay

OM3-N30	805141	Connection to Relay 3 m
OM3-N60	805142	Connection to Relay 6 m
OM3-N100	805146	Connection to Relay 10 m

4. Cable Power Supply

LW-24V-3	805500	Connection to Power Supply 24VAC 3 m
LW-24V-6	805501	Connection to Power Supply 24VAC 6 m
LW-24V-10	805502	Connection to Power Supply 24VAC 10 m

Technical Data

Max. working pressure PS:	LW4: 60 bar
Max. test pressure PT:	LW4: 66 bar
Burst Pressure:	LW4: 230bar
Supply voltage / current	24VAC, 50/60Hz, ±10%, 0.05A
Vibration resistance (EN60068-2-6)	max. 4g, 10...250Hz
Medium temperature	-20...+80°C
Ambient/Storage temperature	-20...+50°C
Protection class	IP65 (IEC529/EN 60529)



LW4

Accessories and Spare Parts

Type	Part No.	Description	Weight
ECT-623	804421	Transformer 230 VAC / 24VAC, 60 VA	1.20 kg
OM-HFC-K01	805081	Sealing-Kit LW4 (contains all gaskets incl. adapter gaskets)	

Time Delay Alarm:	120 sec
Output Signal	24V AC, Inductive load: 35 VA Time delay 20 sec
Alarm contact:	max. 3 A, 230 VAC, SPDT dry contact
Weight	850...920 g incl. adapter

⚠ Warning: R1234ze classified as A2L. Use of product only for non-explosive environment, non ATEX zone.

Pressure Controls with Adjustable Setpoints

Features PS1/PS2

- Adjustable pressure range
- Narrow adjustable differential depending on model
- High rated SPDT contacts for all versions
- Chatter resistant contacts
- Dual pressostats with two independent SPDT controls
- Standard pressure connection 7/16"-20 UNF for 1/4" SAE male flare connection, alternative pressure connectors including 6 mm ODF solder connection
- Automatic and manual reset versions
- Some versions with convertible auto/manual reset
- Locking plate and mounting screws included
- Factory set to customer specification possible
- Low pressure and high pressure versions available with TÜV approval according to EN 12263 to meet requirements of DIN 8901 and EN 378



Single controls PS1



Dual controls PS2

Pressure Controls with Fixed Setpoints

Features PS3

- Maximum Operating Pressure up to 43 bar, Test Pressure up to 48 bar
- Standard factory settings from stock in small volumes
- High and low pressure controls
- High temperature version with snubber for direct compressor mounting (Range 6)
- Direct mounting reduces the number of joints and thus avoiding potential leakage
- Precise setting and repeatability
- IP65 protection if used with the new PS3-Nxx cables with plug (acc. EN 175301-803), no additional gasket required (molded into plug)
- Customer specific versions in multipacks, minimum order quantity 100 pcs
- TÜV approved versions for high and low pressure
- Micro-switch for narrow pressure differentials
- Gold plated contacts for low voltage/current applications



PS3

Features PS4

- High- and low pressure controls
- Precise settings and repeatability
- Cable version with IP67 (IP20 for terminal version)
- Normally open/closed electrical contacts (under standard operating conditions)
- TÜV approved versions
- Compatible with RoHS directive
- Minimum lot size 100 pieces



PS4

⚠ Warning: R1234ze classified as A2L. Use of product only for non-explosive environment, non ATEX zone.

For part selection, please use General Product Guide. For further technical detail see Technical Bulletin/ Datasheet.

Hermetic Liquid Line Filter-Driers Series ADK

ADK filter-driers are used for protection of systems against contaminant.

Features

- Solid block
- Hermetic design, rugged steel shells
- Corrosion resistant epoxy paint
- Cushioned flow for non-turbulent performance
- High water and acid adsorption capacity
- High filtration capacity / efficiency
- No $\text{C}\epsilon$ marking according art. 3.3 PED 97/23 EC
- Max. working pressure PS: 46 bar (680 psi)



ADK

Selection table

Type	Part No.	Connection ODF*/SAE*	Flow capacity [kW] Pressure drop 0.07 bar				
			R448A	R449A	R450A	R513A	R1234ze
ADK-032	003595	1/4"(6 mm) SAE	6.1	5.9	5.9	6.4	6.2
ADK-032S	003596	1/4" ODF	7.4	7.0	7.1	7.7	7.5
ADK-036MMS	003597	6 mm ODF	6.7	6.4	6.4	7.0	6.8
ADK-052	003598	1/4"(6 mm) SAE	6.4	6.1	6.1	6.6	6.5
ADK-052S	003599	1/4" ODF	9.1	8.6	8.7	9.4	9.2
ADK-056MMS	003600	6 mm ODF	8.4	8.0	8.0	8.7	8.5
ADK-053	003601	3/8"(10 mm) SAE	11.9	11.3	11.4	12.3	12.1
ADK-053S	003602	3/8" ODF	13.7	13.1	13.1	14.3	14.0
ADK-0510MMS	003603	10 mm ODF	13.7	13.1	13.1	14.3	14.0
ADK-082	003604	1/4"(6 mm) SAE	6.5	6.2	6.2	6.8	6.7
ADK-082S	003605	1/4" ODF	10.0	9.6	9.6	10.4	10.2
ADK-086MMS	003606	6 mm ODF	9.0	8.5	8.6	9.3	9.1
ADK-083	003607	3/8"(10 mm) SAE	13.8	13.1	13.2	14.3	14.0
ADK-083S	003608	3/8" ODF	13.8	13.1	13.2	14.3	14.0
ADK-0810MMS	003609	10 mm ODF	13.8	13.1	13.2	14.3	14.0
ADK-084	003610	1/2"(12 mm) SAE	21.5	20.5	20.6	22.4	21.9
ADK-084S	003611	1/2" ODF	22.5	21.4	21.5	23.3	22.9
ADK-0812MMS	003612	12 mm ODF	22.1	21.1	21.1	22.9	22.5
ADK-162	003613	1/4"(6 mm) SAE	6.7	6.4	6.4	6.9	6.8
ADK-163	003614	3/8"(10 mm) SAE	14.1	13.4	13.4	14.6	14.3
ADK-163S	003615	3/8" ODF	15.7	15.0	15.0	16.3	16.0
ADK-1610MMS	003616	10 mm ODF	15.7	15.0	15.0	16.3	16.0
ADK-164	003617	1/2"(12 mm) SAE	26.3	25.1	25.1	27.3	26.7
ADK-164S	003618	1/2" ODF	30.2	28.8	28.9	31.4	30.7
ADK-1612MMS	003619	12 mm ODF	27.1	25.9	25.9	28.2	27.6
ADK-165	003620	5/8"(16 mm) SAE	37.7	35.9	36.0	39.1	38.3
ADK-165S	003621	5/8"(16 mm) ODF	41.8	39.8	39.9	43.3	42.5
ADK-303	003622	3/8"(10 mm) SAE	14.9	14.2	14.2	15.4	15.1
ADK-304	003623	1/2"(12 mm) SAE	26.3	25.1	25.1	27.3	26.7
ADK-304S	003624	1/2" ODF	30.3	28.8	28.9	31.4	30.8
ADK-305	003626	5/8"(16 mm) SAE	44.2	42.1	42.2	45.9	45.0
ADK-305S	003627	5/8"(16 mm) ODF	44.3	42.2	42.4	46.0	45.1
ADK-307S	003628	7/8"(22 mm) ODF	55.7	53.0	53.2	57.8	56.6
ADK-414	003629	1/2"(12 mm) SAE	30.9	29.4	29.5	32.1	31.4
ADK-415	003632	5/8"(16 mm) SAE	49.2	46.9	47.0	51.1	50.0
ADK-415S	003633	5/8"(16 mm) ODF	52.9	50.4	50.5	54.9	53.8
ADK-417S	003634	7/8"(22 mm) ODF	65.4	62.4	62.5	67.9	66.6
ADK-757S	003635	7/8"(22 mm) ODF	88.6	84.4	84.7	92.0	90.1
ADK-759S	003636	1-1/8" ODF	98.4	93.8	94.0	102.1	100.1

Note 1: Flow capacities are in accordance with ARI710-86 and DIN894, Liquid temperature at +30°C and at -15°C evaporating temperature.

*) SAE = Flare, ODF = Brazing female

Note 2: Products are classified based on fluid group 2 (non-flammable) according European pressure equipment directive.

For selection of other operating condition, please use Controls Navigator selection program.

Filter-Driers Series FDB

FDB is a hermetic filter-drier in compacted bead style for use on liquid line.

Features

- Compacted bead style (spring loaded)
- Hermetic design, rugged steel shells
- Corrosion resistant epoxy paint
- Solder connection made from copper for easy soldering
- Cushioned flow for non-turbulent performance
- High water adsorption capacity
- High acid adsorption capacity
- High filtration capacity / efficiency
- Filtration first for more effective use of surface area of desiccant
- Max. working pressure PS: 46 bar (680 psi)



FDB-164

Selection table

Type	Part No.	Connection ODF*/SAE*	Flow capacity [kW]				
			Pressure drop 0.07 bar				
			R448A	R449A	R450A	R513A	R1234ze
FDB-032	059305	1/4"(6 mm) SAE	6.0	5.9	5.8	5.5	5.5
FDB-032S	059306	1/4" ODF	9.2	9.1	8.9	8.5	8.5
FDB-052	059307	1/4"(6 mm) SAE	6.2	6.1	6.0	5.7	5.7
FDB-052S	059309	1/4" ODF	9.2	9.1	8.9	8.5	8.5
FDB-053	059308	3/8"(10 mm) SAE	14.7	14.4	14.2	13.5	13.6
FDB-053S	059310	3/8" ODF	18.4	18.0	17.7	16.9	16.9
FDB-082	059311	1/4"(6 mm) SAE	6.4	6.3	6.2	5.9	5.9
FDB-082S	059314	1/4" ODF	9.4	9.2	9.1	8.6	8.7
FDB-083	059312	3/8"(10 mm) SAE	15.0	14.7	14.4	13.8	13.8
FDB-083S	059315	3/8" ODF	18.8	18.4	18.1	17.3	17.3
FDB-084	059313	1/2"(12 mm) SAE	25.1	24.6	24.2	23.0	23.1
FDB-084S	059316	1/2" ODF	26.9	26.4	25.9	24.7	24.8
FDB-162	059317	1/4"(6 mm) SAE	6.4	6.3	6.2	5.9	5.9
FDB-163	059318	3/8"(10 mm) SAE	15.4	15.1	14.9	14.2	14.2
FDB-163S	059321	3/8" ODF	21.9	21.4	21.1	20.1	20.1
FDB-164	059319	1/2"(12 mm) SAE	26.6	26.0	25.6	24.4	24.5
FDB-164S	059322	1/2" ODF	34.2	33.6	33.0	31.4	31.5
FDB-165	059320	5/8"(16 mm) SAE	34.9	34.2	33.6	32.0	32.1
FDB-165S	059323	5/8" ODF	46.4	45.5	44.7	42.6	42.8
FDB-303	059324	3/8"(10 mm) SAE	17.2	16.8	16.5	15.8	15.8
FDB-304	059325	1/2"(12 mm) SAE	30.2	29.6	29.1	27.8	27.8
FDB-304S	003667	1/2" ODF	36.2	35.4	34.8	33.2	33.3
FDB-305	059326	5/8"(16 mm) SAE	38.3	37.6	36.9	35.2	35.3
FDB-305S	059327	5/8" ODF	51.2	50.1	49.3	47.0	47.1
FDB-307S	059328	7/8" ODF	47.3	46.4	45.6	43.4	43.6
FDB-415	059329	5/8"(16 mm) SAE	57.6	56.5	55.5	52.9	53.0
FDB-417S	059330	7/8" ODF	73.5	72.0	70.8	67.5	67.6

Note1: Flow capacities are in accordance with ARI710-86 and DIN8949. Liquid temperature +30°C and -15°C evaporating temperature.

*) SAE = Flare, ODF = Brazing female

Note 2: Products are classified based on fluid group 2 (non-flammable) according European pressure equipment directive.

For selection of other operating condition, please use Controls Navigator selection program.

Filter-Driers Shells Series ADKS-Plus

Features

- Rustproof Aluminum flange cover
- ODF copper fittings for easy soldering
- Rigid core holder from stele (no plastic)
- Service friendly core holder and flange cover
- Optimum flow capacity at low pressure drop
- Temperature range TS: -45°C...+65°C
- Max allowable working pressure PS:
34.5 bar (-10...+65°C)
25.9 bar (-45...-10°C)
- **CE** marking according PED 97/23 EC



ADKS-Plus

Selection table

Type	Part No.	Connection ODF		Nominal Flow capacity [kW]					Number of blocks S48, H48, W48, F48
		mm	inch	R448A	R449A	R450A	R513A	R1234ze	
Conformity assessment cat.I, procedure module A									
485T	883551	16	5/8"	68	67	66	63	63	1
487T	883552	22	7/8"	126	124	122	116	116	
489T	883553		1-1/8"	178	174	172	163	164	
4811T	883554	35	1-3/8"	248	243	239	228	228	
4813TMM	883836	42		270	265	260	248	249	
4817	882603	54	2-1/8"	For suction application					
967T	883555	22	7/8"	139	136	134	127	128	2
969T	883556		1-1/8"	218	214	210	200	201	
9611T	883557	35	1-3/8"	266	260	256	244	245	
9613T	883558		1-5/8"	305	299	294	280	281	
9613TMM	883559	42		309	303	298	284	285	
9617	887215	54		305	299	294	280	281	
1449T	883560		1-1/8"	220	216	212	202	202	3
14411T	883561	35	1-3/8"	306	300	295	281	282	
14413T	883562		1-5/8"	309	303	298	284	284	
14413TMM	883563	42		314	307	302	288	289	
14417T	883564	54	2-1/8"	366	359	353	336	337	
Conformity assessment cat.II, procedure module D1									
19211T	883565	35	1-3/8"	312	306	301	287	287	4
19213T	883566		1-5/8"	344	337	332	316	317	
19213TMM	883567	42		349	342	336	320	321	
19217T	883568	54	2-1/8"	375	368	361	344	345	

Note 1: Flow capacities are in accordance with ARI710-86 and DIN8949. Liquid temperature +30°C and -15°C evaporating temperature.

Note 2: Products are classified based on fluid group 2 (non-flammable) according European pressure equipment directive.

For selection of other operating condition, please use Controls Navigator selection program.

Spare Parts

Description	Type	Part No.
ADKS		
Gasket Set	X 99961	003710
Schrader Nipple 1/4" NPT	X 11562-2	803251
Core Holder	X 99963	003712

Filter-Driers Shells with Quick-Cap Series FDS-24

Features

- Quick-cap flange (one bolt) design makes replacing of cores in a matter of seconds
- Ideal for retrofit, reducing installation / material cost
- Ideal for refrigerant recovery / reclaim units with regular change of filter-drier
- Free volume as a receiver in FDS-24... (580 cm³)
- ODF copper fittings for easy soldering
- Corrosion resistant powder painting of shell body
- Temperature range TS: -45°C...+65°C
- Max allowable working pressure PS:
 - 34.5 bar (-10...+65°C)
 - 25.9 bar (-45...-10°C)
- No **CE** marking according art. 3.3 PED 97/23 EC



FDS-24

Selection table

Type	Part No.	Connection ODF		Nominal liquid flow capacity [kW]				
		mm	inch	Block Core 24				
				R448A	R449A	R450A	R513A	R1234ze
FDS-245	003573	16	5/8"	65.1	63.8	62.7	59.8	59.9
FDS-247	003574	22	7/8"	97.4	95.4	93.8	89.4	89.7
FDS-249	003575		1-1/8"	98.5	96.5	94.9	90.4	90.7
FDS-249MM	003576	28	1-3/8"	99.0	97.0	95.3	90.9	91.1

Note 1: Flow capacities are in accordance with ARI710-86 and DIN8949, Liquid temperature +30°C and -15°C evaporating temperature.

Note 2: Products are classified based on fluid group 2 (non-flammable) according European pressure equipment directive.

For selection of other operating condition, please use Controls Navigator selection program.

Spare Parts

Type	Part No.	Description
X 99967	003716	Gasket Set
X 99968	003717	O-Ring Set
X 99969	003718	Core Holder

Suction Line Filters and Filter-Driers Series ASF and ASD

Features

- Minimum pressure drop due to internal construction and compacted bead style
- Service friendly with 2 Schrader valves for pressure drop measurement
- ODF copper fittings for easy soldering
- Filtration down to 40 microns
- Temperature range TS: -45°C...+50°C
- Max allowable working pressure PS: 27.5 bar
- No **CE** marking according art. 3.3 PED 97/23 EC



ASD-45S7W

Selection table

Type	Part No.	Connection ODF		Nominal Flow capacity Q _n [kW]			
		[mm]	[inch]	R448A R449A	Pressure drop 0.07 bar		R1234ze
					R450A	R513A	
Suction Line filters							
ASF-28 S3	008965		3/8"	8.3	3.7	3.4	3.2
ASF-28 S4	008941		1/2"	13.7	6.5	5.9	5.6
ASF-35 S5	008915	16	5/8"	20.9	9.9	8.9	8.5
ASF-45 S6	008946		3/4"	25.2	13.3	12.0	11.4
ASF-45 S7	008904	22	7/8"	33.1	17.3	15.7	14.9
ASF-50 S9	008908		1-1/8"	47.5	24.8	22.5	21.3
ASF-75 S11	008919	35	1-3/8"	58.3	29.9	27.1	25.7
ASF-75 S13	008940		1-3/8"	62.2	31.6	28.7	27.2
Suction Line Filter-Driers							
ASD-28 S3	008909		3/8"	8.6	4.1	3.7	3.5
ASD-28 S4	008910		1/2"	14.8	6.8	6.2	5.8
ASD-35 S5	008899	16	5/8"	23.7	11.2	10.2	9.6
ASD-45 S6	008925		3/4"	35.3	16.3	14.8	14.0
ASD-45 S7	008896	22	7/8"	43.2	22.8	20.7	19.6
ASD-50 S9	008881		1-1/8"	68.4	32.3	29.3	27.8
ASD-75 S11	008891	35	1-3/8"	57.6	40.8	37.0	35.1
ASD-75 S13	008953		1-3/8"	86.4	47.6	43.2	40.9

Note1: Nominal flow capacity at +4°C evaporating temperature (saturated condition/dew point) and a pressure drop of 0.21 bar between inlet and outlet of ASF/ASD.

Note2: Products are classified based on fluid group 2 (non-flammable) according European pressure equipment directive.

For selection of other operating condition, please use Controls Navigator selection program.

Suction Line Filters and Filter-Drier Shells Series BTAS

Features

- Corrosion-free brass body ideal for suction line applications
- Extremely large filtration area for optimum flow capacity
- Low pressure drop
- Filtration down to 40 microns
- Temperature range TS: -45°C...+50°C
- Max allowable working pressure PS: 24 bar
- UL File No.: SA 3124



BTAS

Selection table Suction Line Shells with Filter Core

Type	Part No.	Connection ODF		Nominal Flow capacity Q _n [kW]				Filter Core	
		[mm]	[inch]	R448A/R449A	R450A	R513A	R1234ze	Type	Part No.
No CE marking according to art. 3.3 PED 97/23. HP marking according to German pressurized vessel directive									
BTAS 25	015353		5/8"					A2F	009907
BTAS 27	015354	22	7/8"	31.7	16.3	14.8	14.6		
BTAS 39	015355		1-1/8"	50.4	24.8	22.5	22.2	A3F	009909
BTAS 311	015356	35	1-3/8"	54.0	27.5	25.0	24.7		
BTAS 313	015357		1-5/8"	86.4	44.2	40.1	39.6		
BTAS 342	015358	42		86.4	44.2	40.1	39.6		
BTAS 317	015359	54	2-1/8"	104.3	54.4	49.3	48.7	A4F	009911
BTAS 417	015360	54	2-1/8"	190.7	98.6	89.4	88.3		
CE marked, Conformity assessment cat. I, procedure module A									
BTAS 521	015361		2-5/8"	302.2	153.0	138.7	137.0	A5F	009913
BTAS 525	015362		3-1/8"	370.6	190.4	172.6	170.4		
BTAS 580	015363	80		370.6	190.4	172.6	170.4		

Note: Filter Core has to be ordered separately.

Selection table Suction Line Shells with Filter-Drier Core

Type	Part No.	Connection ODF		Nominal Flow capacity Q _n [kW]				Filter Core	
		[mm]	[inch]	R448A/R449A	R450A	R513A	R1234ze	Type	Part No.
No CE marking according to art. 3.3 PED 97/23. HP marking according to German pressurized vessel directive									
BTAS 25	015353		5/8"	16.6	8.5	7.7	7.6	A2F-D	009908
BTAS 27	015354	22	7/8"	27.0	13.9	12.6	12.5		
BTAS 39	015355		1-1/8"	36.0	18.0	16.3	16.1	A3F-D	009910
BTAS 311	015356	35	1-3/8"	50.4	25.2	22.8	22.5		
BTAS 313	015357		1-5/8"	72.0	37.4	33.9	33.5		
BTAS 342	015358	42		72.0	37.4	33.9	33.5		
BTAS 317	015359	54	2-1/8"	82.8	40.8	37.0	36.5	A4F-D	009912
BTAS 417	015360	54	2-1/8"	154.7	78.2	70.9	70.0		
CE marked, Conformity assessment cat. I, procedure module A									
BTAS 521	015361		2-5/8"	219.5	112.2	101.7	100.4	A5F-D	009914
BTAS 525	015362		3-1/8"	259.1	132.6	120.2	118.7		
BTAS 580	015363	80		259.1	132.6	120.2	118.7		

Note 1: Filter-Drier Core has to be ordered separately.

Note 2: Capacity rating at +4°C evaporating temperature (saturated condition/dew point) 0.2 bar pressure drop for R448A/R449A and 0.14 bar for R450A/R513A/R1234ze.

Note 3: Products are classified based on fluid group 2 (non-flammable) according European pressure equipment directive.

AMI / MIA Moisture / Liquid Indicators

The **AMI / MIA** series of Moisture Indicators are designed to monitor the moisture content within the liquid line of a refrigeration system. MIA series with stainless steel body and extended copper tube connections are fully hermetic products without the use of any gasket.

AMI is a highly serviceable product with exchangeable lens assembly and indicator element, available in various configurations including saddle type.

Features

- Max. working pressure PS: AMI: 35 bar, MIA: 45 bar
- Fully hermetic
- Low pressure drop
- Crystal Indicator element for long lifetime and reliability
- Indication of dryness according to ASERCOM recommendation
- Easily determination of moisture content
- Sensitive indicator with calibrated four colors
- Large clear viewing area
- ODF extended tube configurations suitable for all commercial applications
- MIA only:
 - Lightweight and corrosion free stainless steel body (MIA)
 - UL certification File No.: SA 4876 (MIA only, except MIA-078)



MIA



AMI-1 SS



AMI-1 TT

Selection table MIA





Type	Part No.	For tube outside diameter	Picture
MIA 014	805883	1/4"	
MIA 038	805884	3/8"	
MIA 012	805885	1/2"	
MIA 058 / MIA M16	805886	5/8"/16 mm	
MIA 078	805887	7/8"	
MIA 118	805892	1-1/8"	
MIA M06	805880	6 mm	
MIA M10	805881	10 mm	
MIA M12	805882	12 mm	
MIA M28	805891	28 mm	
MIA M10 S Female/Male	805888	10 mm	
MIA M12 S Female/Male	805889	12 mm	

Selection table AMI

Type	Part No.	For tube outside diameter	Picture
AMI-1 TT2 MM	805697	6 mm	
AMI-1 TT2	805655	1/4"	
AMI-1 TT3 MM	805698	10 mm	
AMI-1 TT3	805654	3/8"	
AMI-1 TT4 MM	805699	12 mm	
AMI-1 TT4	805653	1/2"	
AMI-1 TT5	805652	5/8"/16 mm	
AMI-1 TT7	805656	7/8"/22 mm	
AMI-1 TT9 MM	805700	28 mm	
AMI-1 TT9	805651	1-1/8"	

Note: Products are classified based on fluid group 2 (non-flammable) according European pressure equipment directive.

AMI / MIA Moisture / Liquid Indicators

Type	Part No.	For tube outside diameter	Configuration	Picture
AMI-1 SS2 MM	805732	6 mm	Female solder x female solder ODF x ODF	
AMI-1 SS2	805713	1/4"		
AMI-1 SS3 MM	805733	10 mm		
AMI-1 SS3	805714	3/8"		
AMI-1 SS4 MM	805734	12 mm		
AMI-1 SS4	805715	1/2"		
AMI-1 SS5	805716	5/8"/16 mm		
AMI-1 SS7	805717	7/8"/22 mm		
AMI-1 SS9 MM	805703	28 mm		
AMI-1 SS9	805705	1-1/8"		
AMI-1 MM2	805706	1/4"/6 mm	Male flare x male flare	
AMI-1 MM3	805707	3/8"/10 mm		
AMI-1 MM4	805708	1/2"/12 mm		
AMI-1 MM5	805709	5/8"/16 mm		
AMI-1 FM2	805710	1/4"/6 mm		
AMI-1 FM3	805711	3/8"/10 mm	Female flare x male flare	
AMI-1 FM4	805712	1/2"/12 mm		
AMI-2 S11	805704	1-3/8"/35 mm		
AMI-2 S13	805659	1-5/8"/42 mm		
AMI-2 S17	805687	2-1/8"/54 mm		
AMI-3 S7	805650	7/8"/22 mm	Saddle type (for soldering onto the pipe)	
AMI-3 S9	805649	1-1/8"/28 mm		
AMI-3 S11	805648	1-3/8"/35 mm		

Note: Products are classified based on fluid group 2 (non-flammable) according European pressure equipment directive.

Spare parts for AMI

Description	Type	Part No.
Lens assembly kit	X 12978-1	805742
O-Ring	X 99995	805643

Oil Separators OS Series

The OS Oil Separators are used for multiple compressor racks in supermarkets and air conditioning systems.

Features

- Three different construction styles:
 - OSH hermetic style
 - OST with top flange
 - OSB with bottom flange and supporter
- Solid Copper ODF connections
- Stainless steel needle valve and floater
- Temperature range TS: -10°C...+150°C
- Max. allowable pressure: 31 bar
- Permanent magnet to filter metal particles out of the oil circulation
- Corrosion resistant epoxy powder painting
- **CE** marking according PED 97/23 EC
- Comply with UL standard



Selection table

Type	Part No.	Connection ODF		Conformity Assessment Category	Conformity Assessment Procedure	Nominal capacity [kW]					Volume [l]
		[mm]	[inch]			R448A	449A	R1234ze	450A	513A	
OSH-404	881598		1/2"	Cat. I	Module A*	7.4	7.9	3.9	4.6	4.7	2.0
OSH-405	881599	16 mm	5/8"			18.8	20.1	9.9	11.7	12.1	2.4
OSH-407	881600	22 mm	7/8"			29.9	32.1	15.8	18.6	19.2	2.8
OSH-409	881792		1-1/8"			40.9	43.9	21.6	25.4	26.3	3.0
OSH-411	881794	35 mm	1-3/8"			49.3	52.9	26.0	30.7	31.7	3.6
OSH-413	881856		1-5/8"			68.7	73.6	36.2	42.7	44.1	3.6
OSH-611	881940	35 mm	1-3/8"	Cat. II	Module D1	60.6	65.0	32.0	37.7	38.9	6.5
OSH-613	881953		1-5/8"			71.7	76.8	37.8	44.5	46.0	7.9
OSH-642	889022	42 mm				-	-	-	-	-	7.9
OSH-617	881970	54 mm	2-1/8"			108.7	116.5	57.4	67.5	69.8	7.9
OST-404	881860		1/2"			Cat. I	Module A*	7.4	7.9	3.9	4.6
OST-405	881861	16 mm	5/8"	18.8	20.1			9.9	11.7	12.1	2.6
OST-407	881862	22 mm	7/8"	29.9	32.1			15.8	18.6	19.2	3.2
OST-409	881863		1-1/8"	40.9	43.9			21.6	25.4	26.3	3.8
OST-411	881938	35 mm	1-3/8"	49.3	52.9			26.0	30.7	31.7	3.8
OST-413	881939		1-5/8"	68.7	73.6			36.2	42.7	44.1	3.8
OSB-613	881971		1-5/8"	Cat. II	Module D1	71.7	76.8	37.8	44.5	46.0	7.8
OSB-617	881972	54 mm	2-1/8"			108.7	116.5	57.4	67.5	69.8	7.8

Note 1: The nominal capacities at +4°C evaporating temperature.

Note 2: Products are classified based on fluid group 2 (non-flammable) according European pressure equipment directive.

Ball Valves BVE/BVS

The BVE/BVS are ball valves with fully hermetic body design for the Refrigeration and A/C industry.

Features

- Maximum working pressure 45 bar
- BVS models have 7/16-20 UNF – 1/4" flare connection and Schrader valve
- Hermetic design with Laser welded valve body
- Patented (pending) Laser process
- Full flow design for minimal pressure drop
- Two threads at valve body for easy mounting
- Bi-directional flow characteristics
- Valve cap retained by strap attached to main body
- Applied Standards EN 122284, EN 378, EN 12420, PED 97/23/EC
- RoHS 2002/95/EC
- UL File No: SA5312
- **CE** marking according PED 97/23 EC



BVE



BVS

Selection Table

Type BVE	Part No.	Type BVS	Part No.	Connection size ODF		Weight [kg]	Marking
				[inch]	[mm]		
BVE-014	806730	BVS-014	806750	1/4"		0.16	UL EAC (pending)
BVE-M06	806731	BVS-M06	806751		6 mm	0.16	
BVE-038	806732	BVS-038	806752	3/8"		0.16	
BVE-M10	806733	BVS-M10	806753		10 mm	0.16	
BVE-012	806734	BVS-012	806754	1/2"		0.36	
BVE-M12	806735	BVS-M12	806755		12 mm	0.38	
BVE-058	806736	BVS-058	806756	5/8"	16 mm	0.38	
BVE-034	806737	BVS-034	806757	3/4"		0.44	
BVE-078	806738	BVS-078	806758	7/8"	22 mm	0.46	
BVE-118	806739	BVS-118	806759	1 1/8"		1.04	
BVE-M28	806740	BVS-M28	806760		28 mm	1.04	
BVE-138	806741	BVS-138	806761	1 3/8"	35 mm	1.64	
BVE-158	806742	BVS-158	806762	1 5/8"		2.43	
BVE-M42	806743	BVS-M42	806763		42 mm	2.43	
BVE-218	806744	BVS-218	806764	2 1/8"	54 mm	4.55	
BVE-258	806745	BVS-258	806765	2 5/8"		4.65	
BVE-318	806746	BVS-318	806766	3 1/8"		5.00	

Note: Products are classified based on fluid group 2 (non-flammable) according European pressure equipment directive.

Accessories: Special seal caps (Pocan)

BVE/S Valve Size	Part No.	Thread (3)	Quantity per pack
1/4" ... 7/8" (6 ... 22 mm)	806770	M18x1	10 pcs
1-1/8" ... 1 3/8" (28 ... 35 mm)	806771	M27x1	10 pcs
1-5/8" (42 mm) ... 3-1/8"	806772	M36x1	10 pcs



For further technical detail see Technical Bulletin.

Suction Accumulators Series A

The **A series** suction accumulator protects the compressor from liquid slugging and can be used with all common refrigerants.

Features

- Hermetic design
- ODF copper fittings for easy soldering
- Corrosion resistant epoxy powder painting
- Internal orifice with strainer for optimum oil return
- Temperature range TS: -45°C...+65°C
- **CE** marking for certain types according PED 97/23 EC

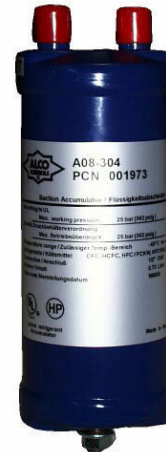

Suction Accumulators Series A

Selection table

Type	Part No.	Connection ODF		Nominal Capacity Qn [kW] 0.07 bar pressure drop								Conformity Assessment		Volume [l]
		[mm]	[inch]	R450A		R513A		R1234ze		R448A R449A		Category	Procedure	
				+4	-7	+4	-7	+4	-7	+4	-7			
A08-304	001973		1/2"	4.1	2.7	3.7	2.4	3.5	2.3	7.2	5.0	No CE -Marking	0.73	
A10-305	001977	16	5/8"	5.8	4.1	5.2	3.7	5.0	3.5	10.8	7.5		0.93	
A12-305	001978	16	5/8"	5.8	4.1	5.2	3.7	5.0	3.5	10.8	7.5		1.16	
A12-306	001979		3/4"	7.8	5.4	7.1	4.9	6.7	4.6	14.4	10.0		1.16	
A14-305	001980	16	5/8"	5.8	4.1	5.2	3.7	5.0	3.5	10.8	7.5		1.40	
A14-306	001987		3/4"	7.8	5.4	7.1	4.9	6.7	4.6	14.4	10.0		1.40	
A06-405	001989	16	5/8"	5.8	4.1	5.2	3.7	5.0	3.5	10.8	7.5		0.93	
A10-405	001990	16	5/8"	5.8	4.1	5.2	3.7	5.0	3.5	10.8	7.5		1.75	
A10-406	001994		3/4"	7.8	5.4	7.1	4.9	6.7	4.6	14.4	10.0		1.75	
A09-506	881995		3/4"	7.8	5.4	7.1	4.9	6.7	4.6	14.4	10.0		2.33	
A09-507	882455	22	7/8"	13.6	9.5	12.3	8.6	11.7	8.1	26.3	18.2	2.33		
A12-506	881996		3/4"	7.8	5.4	7.1	4.9	6.7	4.6	14.4	10.0	3.29		
A12-507	881998	22	7/8"	13.6	9.5	12.3	8.6	11.7	8.1	26.3	18.2	3.29		
A13-507	882007	22	7/8"	13.6	9.5	12.3	8.6	11.7	8.1	26.3	18.2	3.80		
A13-509	882011		1-1/8"	24.5	17.0	22.2	15.3	21.0	14.4	42.5	29.6	3.80		
A17-509	882012		1-1/8"	24.5	17.0	22.2	15.3	21.0	14.4	42.5	29.6	4.87		
A17-511	882013	35	1-3/8"	36.4	24.8	33.0	22.3	31.3	21.0	67.6	47.0	4.87		
A11-607	882014	22	7/8"	13.6	9.5	12.3	8.6	11.7	8.1	26.3	18.2	4.30		
A13-607	882015	22	7/8"	13.6	9.5	12.3	8.6	11.7	8.1	26.3	18.2	4.98		
A13-609	882019		1-1/8"	24.5	17.0	22.2	15.3	21.0	14.4	42.5	29.6	4.98		
A14-611	882020	35	1-3/8"	36.4	24.8	33.0	22.3	31.3	21.0	67.6	47.0	5.48		
A17-613	882022		1-5/8"	57.8	39.8	52.4	35.8	49.7	33.7	102.5	71.2	6.85		
A17-642	889023	42		57.8	39.8	52.4	35.8	49.7	33.7	102.5	71.2	6.85		
A20-613	882021		1-5/8"	57.8	39.8	52.4	35.8	49.7	33.7	102.5	71.2	8.21		
A25-613	882023		1-5/8"	57.8	39.8	52.4	35.8	49.7	33.7	102.5	74.1	Cat.II	Mod. D1	10.23

Note: Products are classified based on fluid group 2 (non-flammable) according European pressure equipment directive.

For selection of other operating condition, please use Controls Navigator selection program.

Saturation Pressure Table and Glide at different Suction Pressures

Temperature [°C]	R450A	R450A	R513A	R513A	R1234ze	R448A	R448A	R449A	R449A
	Liquid pressure [bar]	Vapor pressure [bar]	Liquid pressure [bar]	Vapor pressure [bar]	Liquid/ vapor pressure [bar]	Liquid pressure [bar]	Vapor pressure [bar]	Liquid pressure [bar]	Vapor pressure [bar]
-70	0.07	0.07	0.10	0.10	0.06	0.27	0.18	0.27	0.18
-65	0.10	0.10	0.14	0.14	0.08	0.36	0.25	0.36	0.25
-60	0.14	0.14	0.20	0.19	0.12	0.49	0.34	0.49	0.34
-55	0.19	0.19	0.27	0.26	0.16	0.64	0.45	0.64	0.46
-50	0.26	0.25	0.35	0.35	0.21	0.83	0.60	0.83	0.60
-45	0.35	0.33	0.47	0.46	0.28	1.06	0.78	1.06	0.78
-40	0.45	0.44	0.60	0.60	0.37	1.34	1.00	1.34	1.01
-35	0.58	0.57	0.77	0.76	0.48	1.67	1.27	1.67	1.28
-30	0.75	0.73	0.97	0.97	0.62	2.07	1.60	2.06	1.60
-25	0.94	0.92	1.21	1.21	0.78	2.53	1.99	2.53	1.99
-20	1.18	1.14	1.50	1.50	0.98	3.07	2.44	3.07	2.44
-15	1.45	1.41	1.84	1.83	1.21	3.70	2.97	3.69	2.97
-10	1.78	1.73	2.23	2.23	1.49	4.42	3.59	4.40	3.58
-5	2.16	2.10	2.69	2.68	1.81	5.24	4.30	5.22	4.29
0	2.59	2.53	3.21	3.21	2.18	6.16	5.11	6.14	5.10
5	3.10	3.03	3.81	3.81	2.61	7.21	6.03	7.18	6.02
10	3.67	3.60	4.49	4.49	3.10	8.38	7.08	8.35	7.07
15	4.33	4.24	5.26	5.26	3.66	9.69	8.26	9.65	8.24
20	5.07	4.97	6.12	6.12	4.29	11.14	9.58	11.10	9.56
25	5.90	5.78	7.09	7.09	5.00	12.75	11.07	12.70	11.03
30	6.83	6.70	8.17	8.17	5.80	14.53	12.72	14.47	12.68
35	7.86	7.72	9.37	9.37	6.69	16.48	14.55	16.41	14.50
40	9.01	8.86	10.70	10.70	7.67	18.62	16.58	18.54	16.52
45	10.28	10.12	12.17	12.17	8.76	20.95	18.83	20.87	18.75
50	11.69	11.51	13.78	13.78	9.97	23.49	21.31	23.40	21.21
55	13.23	13.04	15.55	15.55	11.29	26.26	24.03	26.16	23.92
60	14.91	14.72	17.48	17.48	12.75	29.25	27.03	29.15	26.90
65	16.76	16.55	19.59	19.58	14.34	32.50	30.32	32.39	30.16
70	18.77	18.56	21.88	21.88	16.08	36.00	33.93	35.88	33.74

Glide at different saturation pressures [K]

Pressure [bar]	Refrigerant				
	R450A	R513A	R1234ze	R448A	R449A
1	0.62	0.12	0.00	6.12	6.05
5	0.66	0.01	0.00	5.75	5.68
10	0.62	0.00	0.00	5.35	5.30
15	0.56	0.01	0.00	4.90	4.88
20	0.50	0.01	0.00	4.41	4.41
15	0.56	0.01	0.00	4.90	4.88
30	0.35	0.02	0.00	3.34	3.41

