

ALPHA2/ALPHA3

Circulator pumps

50/60 Hz



Note: The test was commissioned and paid for by Grundfos Holding A/S.

be
think
innovate

GRUNDFOS 

1. General description	3
Type key	3
Model type	3
Performance range	4
2. Applications	5
Pumped liquids	6
ALPHAx, the best choice for heating systems	6
ALPHAx features	8
3. Construction	9
Sectional drawing	9
Material specification	9
Motor and control box	9
Unique air vent system	10
4. Installation and startup	11
Installation	11
Electrical data	11
Startup	11
Liquid temperature	11
System pressure	11
Inlet pressure	11
Setting the pump	11
5. Guide to performance curves	13
Curve conditions	14
6. Performance curves and technical data	15
ALPHAx 15-40	15
ALPHAx 15-50 (N)	16
ALPHAx 15-60 (N)	17
ALPHAx 15-80 (N)	18
ALPHAx 25-40 (N)	19
ALPHAx 25-40 A	20
ALPHAx 25-50 (N)	21
ALPHAx 25-60 (N)	22
ALPHAx 25-60 A	23
ALPHAx 25-80 (N)	24
ALPHAx 32-40 (N)	25
ALPHAx 32-50 (N)	26
ALPHAx 32-60 (N)	27
ALPHAx 32-80 (N)	28
7. Accessories	29
Unions and valve kits	29
Insulating kits	29
ALPHA plugs	29
ALPHAx for the German market	30
ALPHAx for the international market	33
ALPHAx for the UK market	38
ALPHAx for the Austrian and Swiss markets	39
8. Grundfos Product Center	43

1. General description

Grundfos ALPHA2/ALPHA3, referred to as ALPHAx in the following, is a complete range of circulator pumps with the following features:

- AUTO_{ADAPT} function which is suitable for most installations.
- Integrated differential-pressure control enabling adjustment of pump performance to the actual system requirements.
- Automatic night setback, selectable.
- Manual summer mode.
- Dry-running protection.
- ALPHA Reader.
- High-torque start.
- Display showing the actual power consumption in watt or the actual flow in m³/h.
- Motor based on permanent-magnet rotor/compact-stator technology.

ALPHAx is energy-optimised and complies with the EuP Directive, Commission Regulation (EC) No 641/2009, which has been effective as from 1 January 2013.

For ALPHAx pumps, the energy efficiency index (EEI) is ≤ 0.20 , categorised as best in class. See page 14.

Grundfos blueflux[®] technology represents the best from Grundfos within energy-efficient motors and frequency converters. Grundfos blueflux[®] meets or exceeds legislative requirements for standard electric motors, such as EuP IE3 grade. See page 14.

The installation of an ALPHAx pump will reduce the power consumption considerably, reduce noise from thermostatic radiator valves and similar fittings and improve the control of the system.

ALPHAx offers a host of advantages:

Energy savings	Automatic control of the differential pressure.
Flexibility	Suitable for installation in existing systems.
Night setback	Automatic night setback, selectable.
Manual summer mode	Summer mode.
Dry-running protection	Protection of the pump against dry running during start and normal operation.
ALPHA Reader	Support for balancing radiators in a heating system.
High-torque start	Improved startup under harsh conditions.
Comfort	Low-noise operation.
Safety	Built-in electrical and thermal protection of the pump.
User friendliness	Simple setting and operation.
Alarms	Alarms indicated in the display.
Warnings	Warnings indicated in the display.

Type key

Example	ALPHAx	25 - 40	180
Pump range			
Standard version			
L: Limited			
Nominal diameter (DN) of suction and discharge ports [mm] (15 = 1", 25 = 1 1/2", 32 = 2")			
Maximum head [dm]			
Cast-iron pump housing			
N: Stainless-steel pump housing			
A: Pump housing with air separator			
Port-to-port length [mm]			

* Exception: UK version, size 15 = 1 1/2".

Model type

This data booklet covers all models. The model type is stated on the nameplate. See fig. 1.



Fig. 1 Model type on nameplate

TM06 1716 2515

The table below shows the ALPHAx models with built-in functions and features.

Functions/features	Model B 2012	Model C 2014	Model D Aug. 2015	ALPHA3 model A Nov. 2015
AUTO _{ADAPT}	•	•	•	•
Proportional pressure	•	•	•	•
Constant pressure	•	•	•	•
Constant curve	•	•	•	•
Automatic night setback	•	•	•	•
Manual summer mode	•	•	•	•
Dry-running protection			•	•
ALPHA Reader				•
High-torque start			•	•
ALPHAx XX-40	•	•	•	•
ALPHAx XX-50	•	•	•	•
ALPHAx XX-60	•	•	•	•
ALPHAx XX-80		•	•	•

Performance range

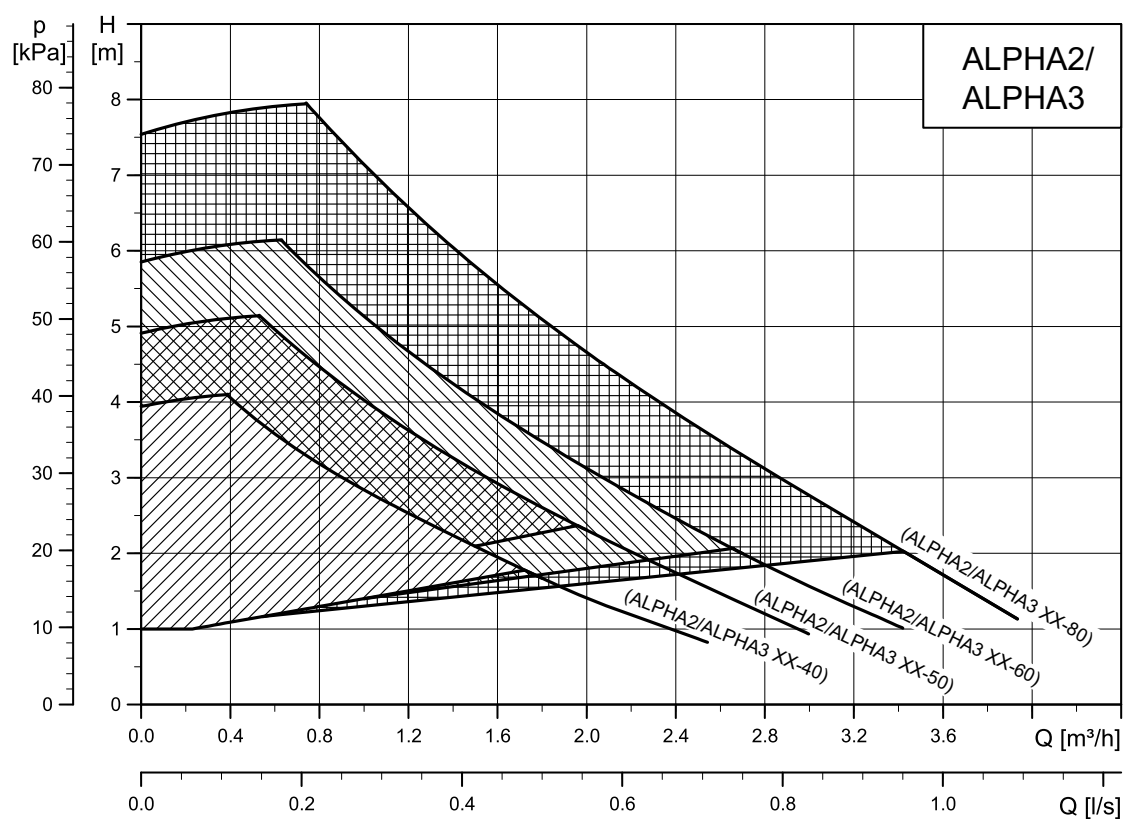

Fig. 2 Performance range, ALPHAx

TM05 2548 2114

2. Applications

ALPHAx is designed for circulating liquids in heating systems. You can also use pumps with stainless-steel pump housing in domestic hot-water systems.

ALPHAx is suitable for the following systems:

- Systems with constant or variable flows where it is desirable to optimise the pump duty point.
- Systems with variable flow-pipe temperature.
- Systems where night setback is desired.

You can select the appropriate pump type for a heating system according to the following guidelines:

Range	Radiator system (Δt 20 °C)	Underfloor heating (Δt 5 °C)	Pump type
[m ²]	[m ³ /h]	[m ³ /h]	ALPHAx
80-120	0.4	1.5	XX-40
120-160	0.5	2.0	XX-50
160-200	0.6	2.5	XX-60
200-300	0.8	3.5	XX-80

Note: The data are approximate values. Grundfos cannot be held responsible for wrong sizing of pumps in heating systems.

ALPHAx is especially suitable for the following:

- Installation in existing systems where the differential pressure of the pump is too high during periods of reduced flow demand.
- Installation in new systems for fully automatic adjustment of the performance to flow demands without the use of bypass valves or similar expensive components.

Examples of systems

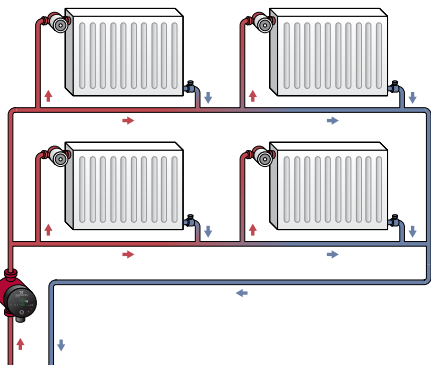

Fig. 3 One-pipe heating system

TM05 2681 0312

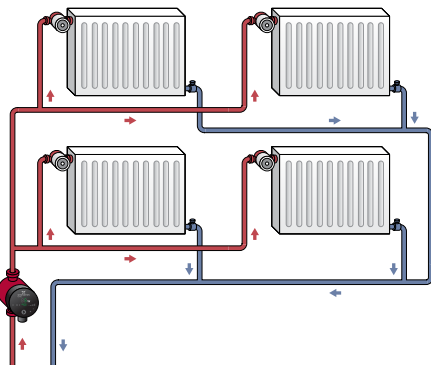

Fig. 4 Two-pipe heating system

TM05 2679 0312

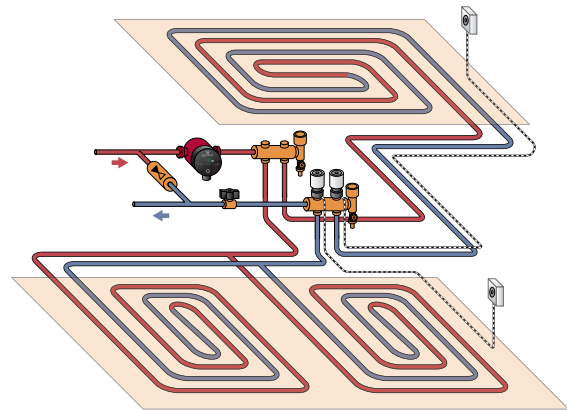

Fig. 5 Underfloor heating system

TM05 2680 0312

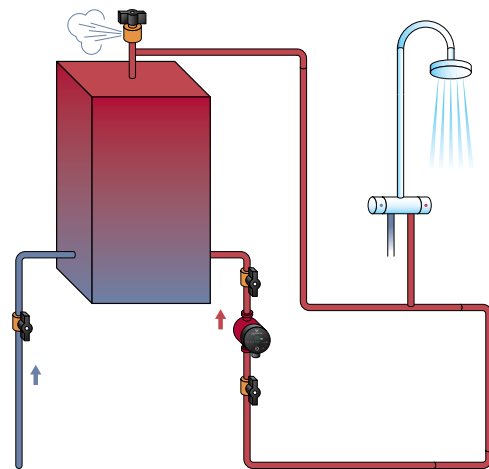

Fig. 6 Domestic hot-water recirculation system

TM05 2678 0312

Pumped liquids

The pump is suitable for the following liquids:

- clean, thin, non-aggressive and non-explosive liquids, not containing solid particles or fibres
- cooling liquids, not containing mineral oil
- softened water.

The kinematic viscosity of water is $\nu = 1 \text{ mm}^2/\text{s}$ (1 cSt) at 20 °C. If you use the pump for a liquid with a higher viscosity, the hydraulic performance of the pump will be reduced.

Example: 50 % glycol at 20 °C means a viscosity of approx. 10 mm²/s (10 cSt) and a reduction of pump performance by approx. 15 %.

Do not use additives that in any way can/will disturb the functionality of the pump.

When selecting a pump, take the viscosity of the pumped liquid into consideration.

ALPHAx, the best choice for heating systems

The heating required in a building varies greatly during the day due to changing outdoor temperatures, solar radiation and heat emanating from people, electric appliances, etc.

Add to this that the need for heating may vary from one section of the building to another and that the thermostatic valves of some radiators may have been turned down by the users.

These circumstances will cause an uncontrolled pump to produce a too high differential pressure when the heat demand is low.

Possible consequences:

- too high energy consumption
- irregular control of the system
- noise in thermostatic radiator valves and similar fittings.

ALPHAx automatically controls the differential pressure by adjusting the pump performance to the actual heat demand, without the use of external components.

The pump has the following control modes:

- AUTO_{ADAPT} control
- proportional-pressure control
- constant-pressure control
- constant-curve control
- balancing control.

AUTO_{ADAPT}

The integrated AUTO_{ADAPT} function is especially developed for the following:

- underfloor heating systems
- two-pipe heating systems.

The AUTO_{ADAPT} function (factory setting) automatically adjusts the pump performance to the actual heat demand, i.e. the size of the system and the changing heat demand. The performance is adjusted gradually over time. You cannot expect an optimum pump setting from day one.

If the power supply fails or is disconnected, the pump stores the AUTO_{ADAPT} setting in an internal memory and will resume the automatic adjustment when the power supply has been restored.

Operation

The AUTO_{ADAPT} function enables ALPHAx to control the pump performance automatically:

- adjustment of the pump performance to the heat demand in the system
- adjustment of the pump performance to the variations in load over 24 hours.

In AUTO_{ADAPT} mode, the pump is set to proportional-pressure control.

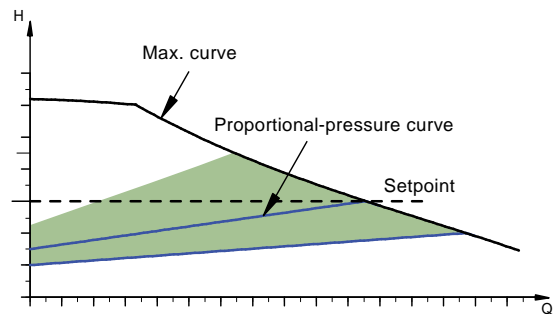

Fig. 7 AUTO_{ADAPT} performance range

The AUTO_{ADAPT} function differs from other control functions as it moves the control curve within a performance range. The marked area indicates the limits for the movement of the proportional-pressure curve. See fig. 7.

In a system with an uncontrolled pump, a pressure rise will often cause flow-generated noise in the thermostatic radiator valves. This noise will be reduced considerably with ALPHAx.

Proportional-pressure control

Proportional-pressure control adjusts the pump performance to the actual heat demand in the system, but the pump performance follows the selected performance curve, PP1, PP2 or PP3. See fig. 8 where PP2 has been selected. See [Change of performance](#) for further information.

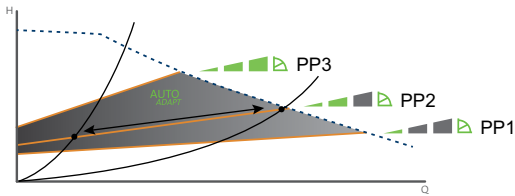

Fig. 8 Three proportional-pressure curves/settings

TM05 3064 0912

Constant-pressure control

Constant-pressure control adjusts the pump performance to the actual heat demand in the system, but the pump performance follows the selected performance curve, CP1, CP2 or CP3. See fig. 9 where CP1 has been selected. See [Change of performance](#) for further information.

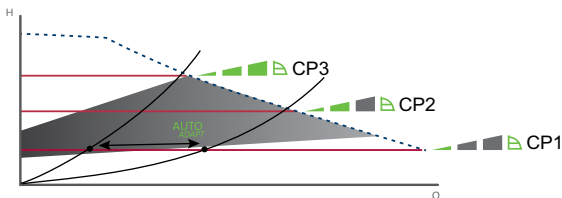

Fig. 9 Three constant-pressure curves/settings

TM05 3066 0912

The selection of the right constant-pressure setting depends on the characteristics of the heating system in question and the actual heat demand.

Constant-curve control

At constant-curve/constant-speed operation, the pump runs at a constant speed, independent of the actual flow demand in the system. The pump performance follows the selected performance curve, I, II or III. See fig. 10 where II has been selected. See [Change of performance](#) for further information.

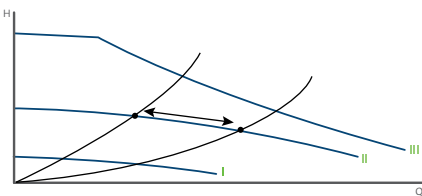

Fig. 10 Three constant-curve/constant-speed settings

TM05 3068 0912

The selection of the right constant-curve/constant-speed setting depends on the characteristics of the heating system in question and the number of taps likely to be opened at the same time.

Advantages of ALPHA pump control

In ALPHAx, control is effected by adapting the differential pressure to the flow (proportional-pressure and constant-pressure control).

Contrary to an uncontrolled pump, the proportional-pressure-controlled ALPHAx reduces the differential pressure as a result of falling heat demand.

If the heat demand falls, for instance due to solar radiation, the thermostatic radiator valves will close, and, for the uncontrolled pump, the flow resistance of the system will rise, for instance from A_1 to A_2 . See fig. 11.

In a heating system with an uncontrolled pump, this situation will cause a pressure rise in the system by ΔH_1 .

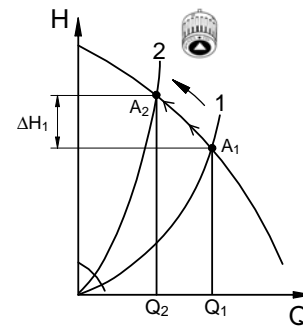

Fig. 11 Uncontrolled pump

TM01 9119 5002

In a system with an ALPHAx pump, the pressure will be reduced by ΔH_2 and result in a reduced energy consumption. See fig. 12.

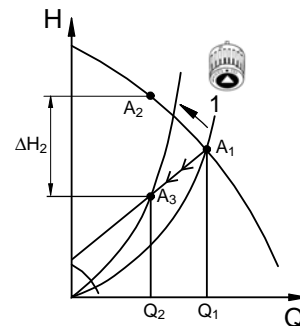



Fig. 12 Pump in proportional-pressure control mode

TM01 9120 5002

ALPHAx features

Automatic night setback

You enable the automatic night setback with the  button on the control box.

Factory setting: Disabled.

Note: If you have set the pump to speed I, II or III, you cannot enable automatic night setback.

Once you have enabled automatic night setback, the pump automatically changes between normal duty and night setback. The changeover depends on the flow-pipe temperature measured by the integrated temperature sensor.

Function

If automatic night setback is to be used in the system, you must install the pump in the flow pipe.

Changeover between normal duty and night setback depends on the flow-pipe temperature.

The pump automatically changes over to night setback when a flow-pipe temperature drop of more than 10 to 15 °C within approx. two hours is registered. The temperature drop must be at least 0.1 °C/min.

Changeover to normal duty takes place without a time lag when the flow-pipe temperature has increased by approx. 10 °C.

Manual summer mode

You can select the manual summer mode from model C.

You enable the manual summer mode with the  button on the control box.

Function

In the manual summer mode, the pump is automatically started frequently at low speed to avoid blocking rotor as well as sticky valves and non-return valves. The display is turned off.

If any alarms occur during the manual summer mode, no alarms will be shown. When you deactivate the manual summer mode again, only the actual alarms will be displayed.

You deactivate the manual summer mode by pressing any of the buttons, and then the pump returns to the previous mode and setting.

If you have enabled the automatic night setback mode before setting the manual summer mode, the pump will return to automatic night setback mode after the manual summer mode.

Dry-running protection

Dry-running protection is active from model D

The new active dry-run feature protects the reliable wet-runner design of the ALPHAx pumps.

Dry-running protection protects the pump against dry running during start and normal operation. The user will be informed via an error code in the display.

ALPHA Reader

ALPHA Reader is selectable from ALPHA3

This feature is used for balancing radiators in a heating system in a fast and safe way for the benefit of the installer as well as the end-user.

ALPHA Reader provides read-out of internal data from the pump. See fig. 13. The data will be transmitted to a handheld device.



Fig. 13 ALPHA Reader

High-torque start

High-torque start is active from model D

In case of a blocked rotor, the pump will vibrate with the frequency of around 3 Hz during startup. Any dirt deposits that might prevent the impeller from rotating will be broken up swiftly and the pump will resume normal operation.

TM06 4452 2315

3. Construction

ALPHAx is designed for long and trouble-free operation as a canned-rotor type, i.e. pump and motor form an integral unit without shaft seal and with only two gaskets for sealing. The bearings are lubricated by the pumped liquid. These constructions ensure maintenance-free operation.

The pump is characterised by the following:

- Permanent-magnet rotor/compact-stator motor which contribute to high efficiency and high starting torque.
- Ceramic shaft and radial bearings which contribute to long life.
- Carbon thrust bearing which contributes to long life.
- Stainless-steel rotor can, bearing plate and rotor cladding which contribute to corrosion-free long life.
- Composite impeller which contributes to corrosion-free long life.
- Cast-iron or stainless-steel pump housing which contributes to flexibility.
- Automatic air venting which contributes to easy commissioning.
- Compact design featuring pump head with integrated control box and control panel which fits into most common installations.

Sectional drawing

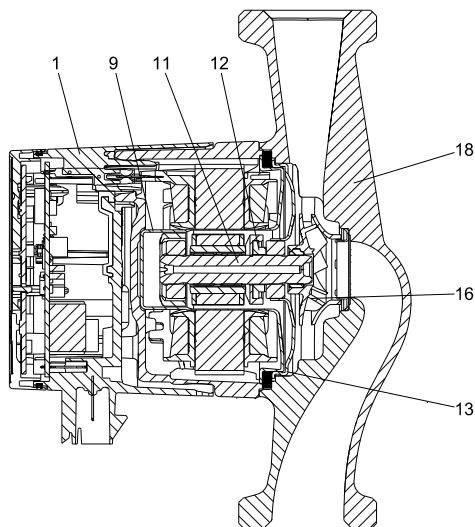

Fig. 14 Position numbers

TM05 2518 0112

Material specification

Pos.	Description	Material	EN/DIN	AISI/ASTM
1	Controller complete	Composite, PC		
9	Rotor can	Stainless steel	1.4401	316
	Radial bearing	Ceramics		
11	Shaft	Ceramics		
	Rotor cladding	Stainless steel	1.4401	316
12	Thrust bearing	Carbon		
	Thrust bearing retainer	EPDM rubber		
13	Bearing plate	Stainless steel	1.4301	304
16	Impeller	Composite, PES		
18	Pump housing	Cast iron	EN-GJL-150	A48-150B
		Stainless steel	1.4308	351 CF8
	Gaskets	EPDM rubber		

Motor and control box

The motor is a 4-pole synchronous permanent-magnet motor.

The pump controller is incorporated in the control box, which is fitted to the stator housing with two screws and connected to the stator via a terminal plug.

The control box has an integrated control panel with three push-buttons (pos. 1, 2 and 3) and a 2-digit 7-segment display. See fig. 15.

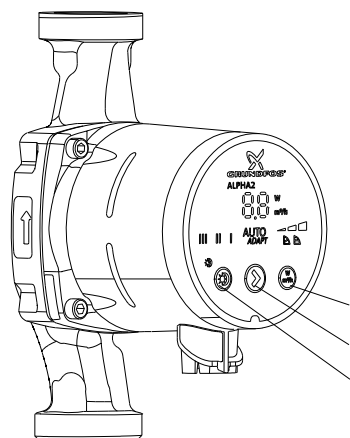

TM05 2519 0112

Fig. 15 Position of push-buttons

Pos.	Description
1	Push-button for selection of pump setting.
2	Push-button for enabling or disabling of automatic night setback or manual summer mode. You have to activate both settings manually.
3	Push-button for selection of parameter to be shown in the display, i.e. actual power consumption in watt or actual flow in m ³ /h.

The display is on when you have switched on the power supply. The display shows the actual pump power consumption in watt (integer) or the actual flow in m³/h, in steps of 0.1 m³/h, during operation.

Accuracy: ± 5 %

Faults preventing the pump from operating properly are indicated by fault codes in the display, for example blocked rotor.

The following faults can be indicated in the display:

- blocked rotor (E1)
- insufficient supply voltage (E2)
- electrical fault (E3).

Figures 16 and 17 show the possible control box positions in heating systems as well as in air-conditioning and cold-water systems.

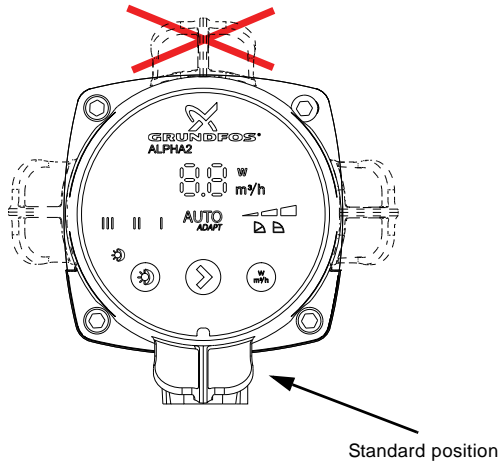

TM05 2520 0112

Fig. 16 Possible control box positions, heating systems

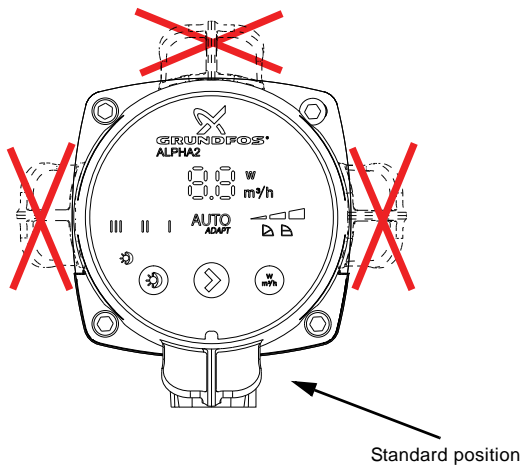

TM05 2700 0112

Fig. 17 Possible control box position, air-conditioning and cold-water systems

The plug incorporates cable relief and a locking function for securing the connection of the supply cable.



TM05 3073 0612

Fig. 18 ALPHA plug with cable relief and ALPHA plug, angled, with fixed cable

Unique air vent system

The pump housing with air separator is installed in systems where the liquid contains so much air that a circulator pump without air separator cannot start or keep up a continuous circulation. The pump housing is available only for upward water flows.

The air-containing liquid is guided from the suction port to the nozzle of the air-separating chamber and caused to circulate considerably in the relatively large chamber, thus creating a relatively lower pressure at the back (top) of the chamber. This lower pressure combined with the reduced velocity of the liquid in the air-separating chamber will cause a separation of air from the liquid. Due to its lower density, the air will escape through an automatic air vent fitted to the air-separating chamber.

The pump housing has an Rp 3/8 tapping for fitting of an air vent. The air vent is not supplied with the pump.

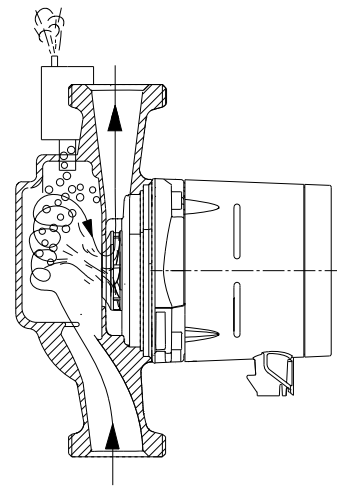

TM05 2521 0112

Fig. 19 Pump housing with air-separating chamber

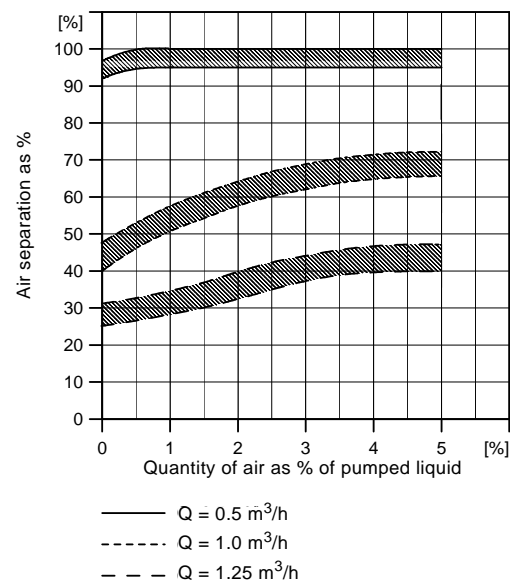

TM00 9101 1097

Fig. 20 Air separation

4. Installation and startup

Installation

In most cases, the installation of ALPHAx is reduced to the mechanical installation and connection to the power supply.

Always install the pump with horizontal motor shaft.

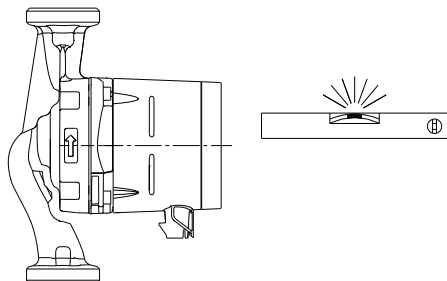

Fig. 21 Horizontal motor shaft

TM05 2522 0112

Electrical data

Supply voltage	1 x 230 V ± 10 %, 50/60 Hz, PE.
Motor protection	The pump requires no external motor protection.
Enclosure class	IPX4D.
Insulation class	F.
Relative air humidity	Maximum 95 %.
Ambient temperature	0-40 °C.
Temperature class	TF110 to CEN 335-2-51.
EMC (electromagnetic compatibility)	2004/108/EC Standards used: EN 55014-1:2006 and EN 55014-2:1997.
Sound pressure level	≤ 43 dB(A).

Startup

Do not start the pump until you have filled the system with liquid and vented it. Furthermore, the required minimum inlet pressure must be available at the pump inlet. You cannot vent the system cannot through the pump.

The pump is self-venting. Therefore, do not vent the pump before startup.

Liquid temperature

Cast-iron pumps: 2-110 °C.

In domestic hot-water systems, we recommend that you keep the liquid temperature between 45 and 65 °C to eliminate the risk of lime precipitation and legionella bacteria.

To avoid condensation in the control box and stator, the liquid temperature must always be higher than the ambient temperature. See table below.

Ambient temperature [°C]	Liquid temperature	
	Min. [°C]	Max. [°C]
0	2	110
10	10	110
20	20	110
30	30	110
35	35	90
40	40	70

The ALPHAx pump can, however, run at ambient temperatures higher than the liquid temperature if the plug connection in the pump head is pointing downwards. See figs 16 and 17.

System pressure

PN 10: Maximum 1.0 MPa (10 bar).

Inlet pressure

To avoid cavitation noise and damage to the pump bearings, the following minimum pressures are required at the pump suction port.

Liquid temperature	75 °C	90 °C	110 °C
	0.5 m head	2.8 m head	10.8 m head
Inlet pressure	0.005 MPa	0.028 MPa	0.108 MPa
	0.05 bar	0.28 bar	1.08 bar

Setting the pump

With the push-button on the control box, you can set the electronically controlled pump to the following:

- AUTO_{ADAPT}
- three proportional-pressure curves (PP1, PP2, PP3)
- three constant-pressure curves (CP1, CP2, CP3)
- three constant curves/constant speeds (I, II, III).

Factory setting

The push-buttons on the pump control box have been factory-set as shown in the table below.

These settings are suitable for a large majority of all single-family houses.

Pump type	Setting	Automatic night setback	Manual summer mode
ALPHAx XX-40	AUTO _{ADAPT}	Disabled	Disabled
ALPHAx XX-50			
ALPHAx XX-60			
ALPHAx XX-80			

Change of performance

The pump performance (flow and head) can be changed by pressing the control box push-button as indicated in fig. 22 and the table below.

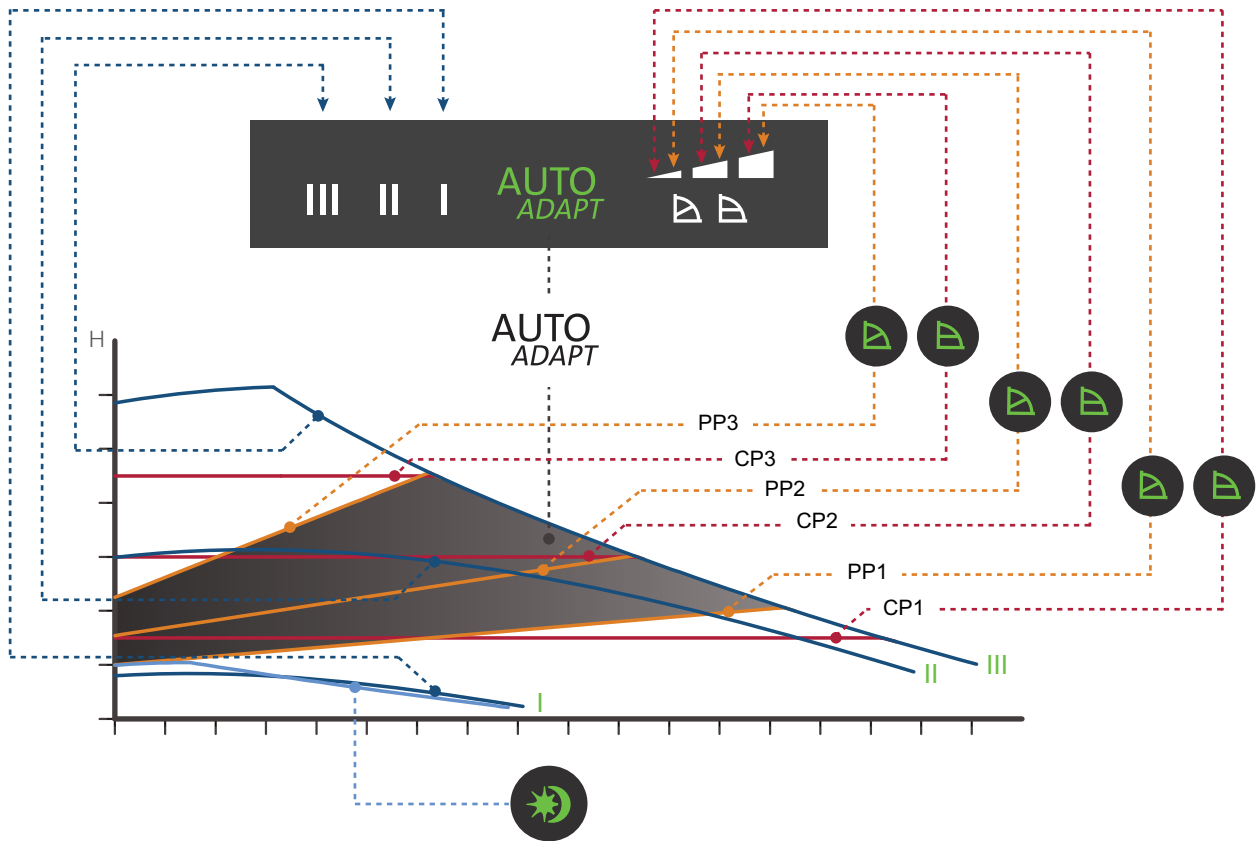

TM05 2771 0412

Fig. 22 Pump setting in relation to pump performance

Setting	Pump curve	Function
AUTO _{ADAPT} factory setting	Highest to lowest proportional-pressure curve	The AUTO _{ADAPT} function enables the pump to control the pump performance automatically within a defined performance range. See fig. 22. <ul style="list-style-type: none"> • Adjustment of the pump performance to the size of the system. • Adjustment of the pump performance to the variations in load over time. In AUTO _{ADAPT} , the pump is set to proportional-pressure control.
PP1	Lowest proportional-pressure curve	The duty point of the pump will move up or down on the lowest proportional-pressure curve, depending on the heat demand in the system. See fig. 22. The head (pressure) is reduced at falling heat demand and increased at rising heat demand.
PP2	Intermediate proportional-pressure curve	The duty point of the pump will move up or down on the intermediate proportional-pressure curve, depending on the heat demand in the system. See fig. 22. The head (pressure) is reduced at falling heat demand and increased at rising heat demand.
PP3	Highest proportional-pressure curve	The duty point of the pump will move up or down on the highest proportional-pressure curve, depending on the heat demand in the system. See fig. 22. The head (pressure) is reduced at falling heat demand and increased at rising heat demand.
CP1	Lowest constant-pressure curve	The duty point of the pump will move out or in on the lowest constant-pressure curve, depending on the heat demand in the system. See fig. 22. The head (pressure) is kept constant, irrespective of the heat demand.
CP2	Intermediate constant-pressure curve	The duty point of the pump will move out or in on the intermediate constant-pressure curve, depending on the heat demand in the system. See fig. 22. The head (pressure) is kept constant, irrespective of the heat demand.
CP3	Highest constant-pressure curve	The duty point of the pump will move out or in on the highest constant-pressure curve, depending on the heat demand in the system. See fig. 22. The head (pressure) is kept constant, irrespective of the heat demand.
III	Speed III	The pump runs on a constant curve which means that it runs at a constant speed. In speed III, the pump is set to run on the maximum curve under all operating conditions. See fig. 22. You can obtain quick venting of the pump by setting the pump to speed III for a short period.
II	Speed II	The pump runs on a constant curve which means that it runs at a constant speed. In speed II, the pump is set to run on the intermediate curve under all operating conditions. See fig. 22.
I	Speed I	The pump runs on a constant curve which means that it runs at a constant speed. In speed I, the pump is set to run on the minimum curve under all operating conditions. See fig. 22.
	Automatic night setback and manual summer mode	The pump changes to the curve for automatic night setback, i.e. absolute minimum performance and power consumption, provided that certain conditions are met. In manual summer mode, the pump is automatically started frequently at low speed to avoid a blocking rotor. The display is turned off. See section ALPHAx features .

5. Guide to performance curves

Each pump setting has its own performance curve (Q/H curve). However, $AUTO_{ADAPT}$ covers a performance range. A power curve (P1 curve) belongs to each Q/H curve. The power curve shows the pump power consumption (P1) in watt at a given Q/H curve.

The P1 value corresponds to the value that you can read from the pump display. See fig. 23.

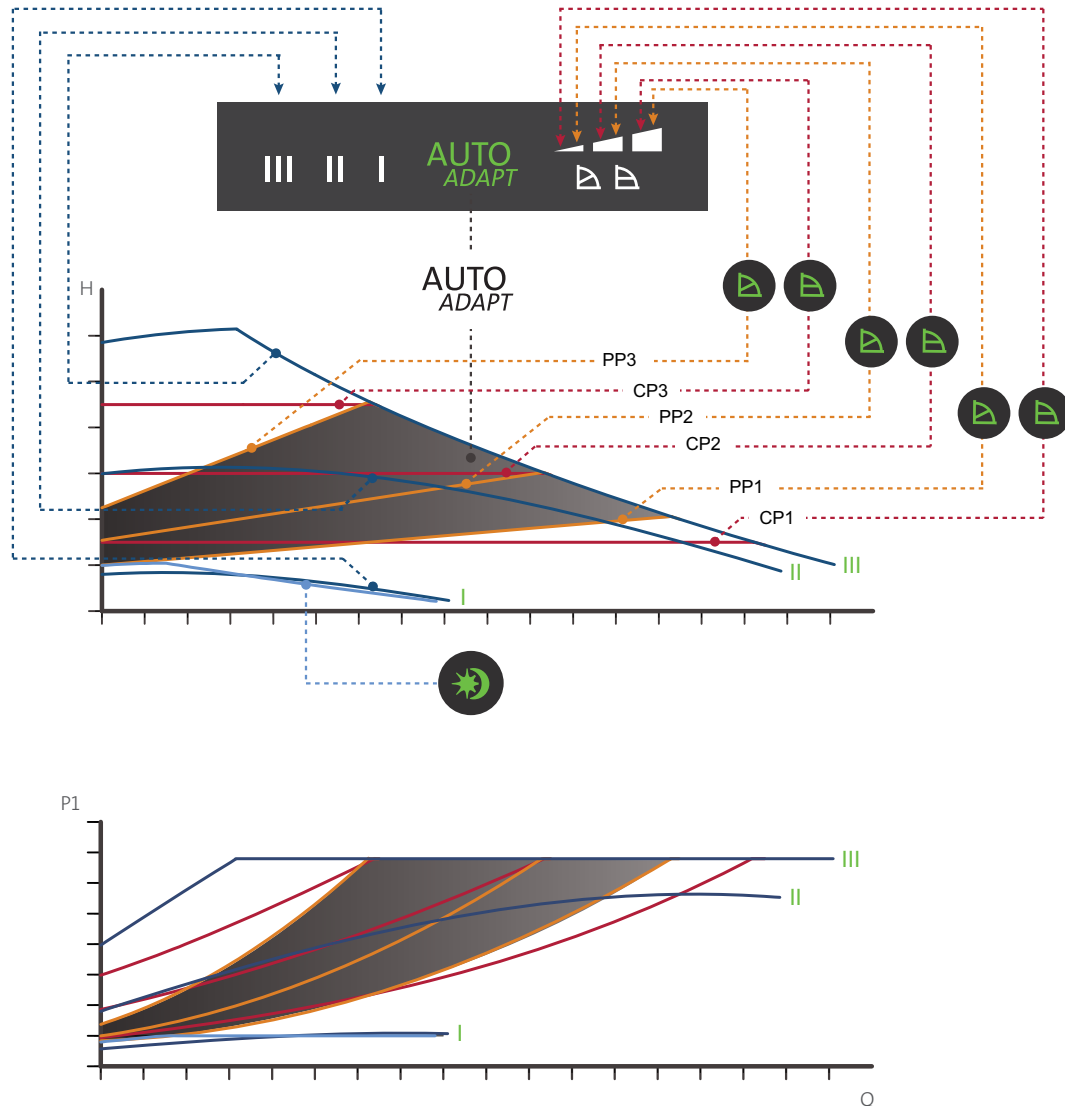



Fig. 23 Performance curves in relation to pump setting

Setting	Pump curve
$AUTO_{ADAPT}$ (factory setting)	Setpoint within the marked area
PP1	Lowest proportional-pressure curve
PP2	Intermediate proportional-pressure curve
PP3	Highest proportional-pressure curve
CP1	Lowest constant-pressure curve
CP2	Intermediate constant-pressure curve
CP3	Highest constant-pressure curve
III	Constant curve/constant speed III
II	Constant curve/constant speed II
I	Constant curve/constant speed I
	Curve for automatic night setback/manual summer mode

TM05 2578 0312

Curve conditions

The guidelines below apply to the performance curves on pages 15 to 27:

- Test liquid: airless water.
- The curves apply to a density of $\rho = 983.2 \text{ kg/m}^3$ and a liquid temperature of $60 \text{ }^\circ\text{C}$.
- All curves show average values and should not be used as guarantee curves. If a specific minimum performance is required, make individual measurements.
- The curves for speeds I, II and III are marked.
- The curves apply to a kinematic viscosity of $\nu = 0.474 \text{ mm}^2/\text{s}$ (0.474 cSt).
- The conversion between head H [m] and pressure p [kPa] has been made for water with a density of $\rho = 1000 \text{ kg/m}^3$. For liquids with other densities, for example hot water, the discharge pressure is proportional to the density.
- Curves obtained according to EN 16297.

Symbols used on the following pages



Fig. 24 VDE comparison test energy efficiency index

ALPHAx has been tested as the "Best in Test" by VDE in a comparison test on energy efficiency performed among six different pump manufacturers.

Note: The test was commissioned and paid for by Grundfos Holding A/S.

For ALPHAx pumps, the average energy efficiency index (EEI) is 0.15 categorised as best in class.

ALPHAx with $\text{AUTO}_{\text{ADAPT}}$ function is the preferred choice for domestic installations and a true efficiency frontrunner.

The energy efficiency index (EEI) is the difference between the annual energy consumption of the ALPHAx and the standard consumption of a typical similar model.

The $\text{AUTO}_{\text{ADAPT}}$ function ensures an energy consumption that is even lower than the indicated EEI, but due to the calculation method, this is not reflected in the EEI.

The ALPHAx EEI is far below the EuP 2013 and 2015 requirements and even exceeds the best in class benchmark level. See fig. 25.

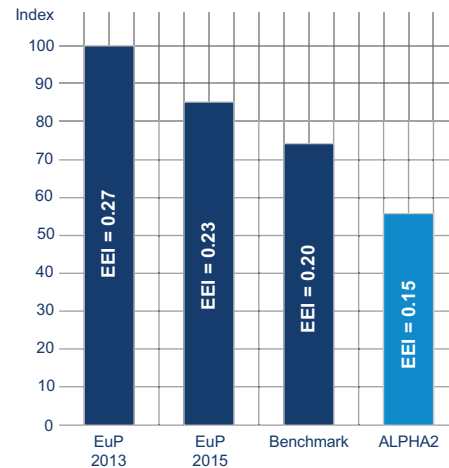

Fig. 25 EEI limits and the current positioning of the ALPHAx

With an energy efficiency index (EEI) well below the EuP benchmark level, you can achieve energy savings of up to 90 % compared to a typical circulator and thus a remarkably fast return on investment. This means, of course, that ALPHAx more than meets the standards of the EuP legislation.

For more information about the new energy directive, please visit:



energy.grundfos.com

TM05 4002 1912

TM05 2712 0412

TM05 2683 0412

6. Performance curves and technical data

ALPHAx 15-40

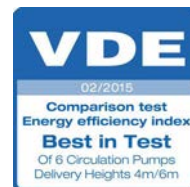
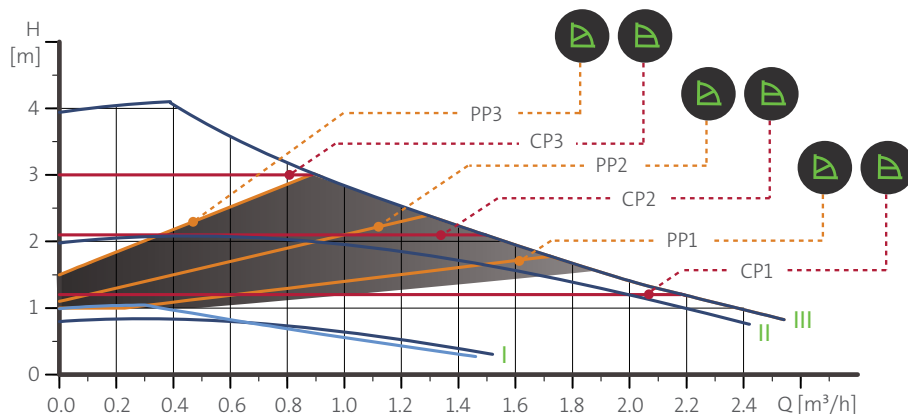

Note: The test was commissioned and paid for by Grundfos Holding A/S.

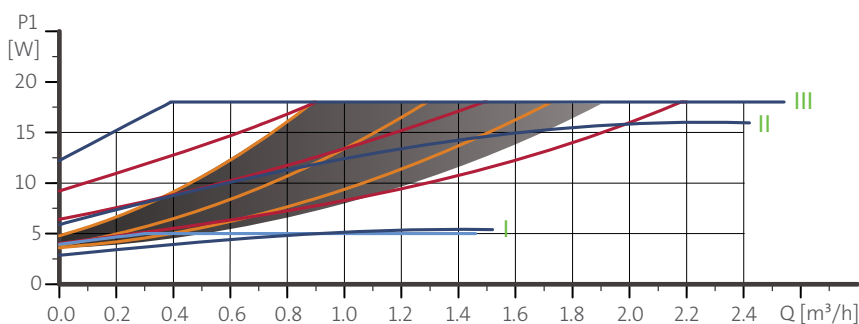

TM05 1672-4111 - TM05 2712 0412 - TM05 2683 0312

Speed	P1 [W]	$I_{1/1}$ [A]
AUTO _{ADAPT}	4-18	0.04 - 0.18
Min.	3	0.04
Max.	18	0.18

Connections: See [Unions and valve kits](#), page 29.

System pressure: Max. 1.0 MPa (10 bar).

Liquid temperature: 2-110 °C (TF 110).

Specific EEI: ≤ 0.15 .

The pump incorporates overload protection.

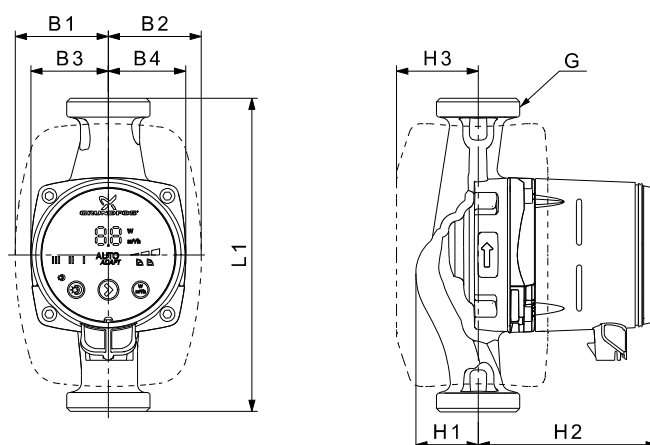

TM05 2364 5011

Pump type	Dimensions [mm]									Weights [kg]		Ship. vol. [m³]
	L1	B1	B2	B3	B4	H1	H2	H3	G	Net	Gross	
ALPHAx 15-40	130	60.5	60.5	44.5	44.5	35.8	103.5	52	G 1	1.8	2.0	0.00364

See product numbers and QR codes in section [Accessories](#).

ALPHAx 15-50 (N)

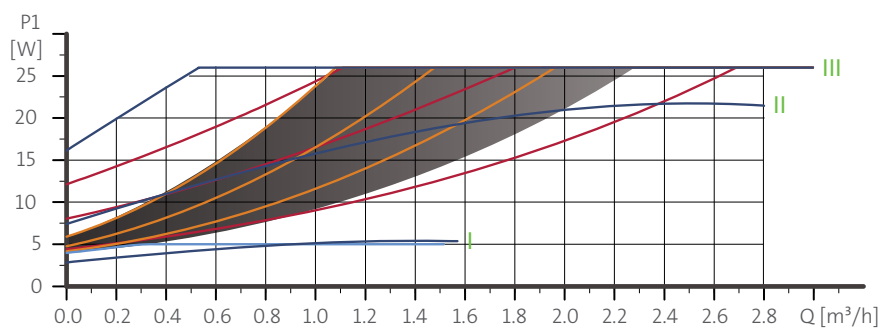
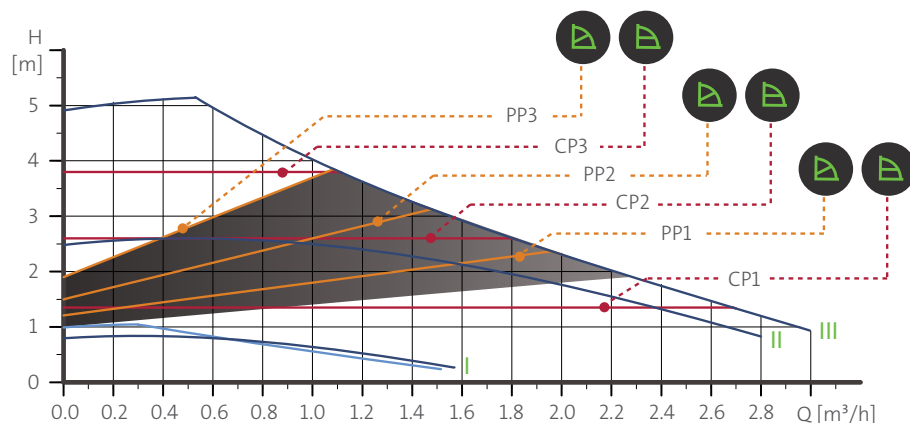

Speed	P1 [W]	$I_{1/1}$ [A]
AUTO _{ADAPT}	4-26	0.04 - 0.24
Min.	3	0.04
Max.	26	0.24

Connections: See [Unions and valve kits](#), page 29.

System pressure: Max. 1.0 MPa (10 bar).

Liquid temperature: 2-110 °C (TF 110).

Specific EEI: ≤ 0.16 .

The pump incorporates overload protection.

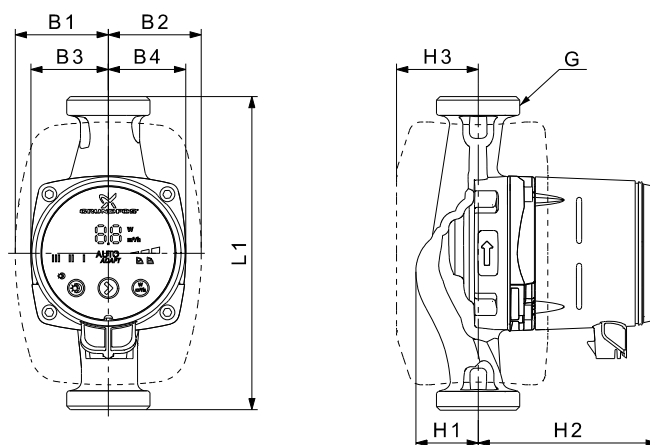

Pump type	Dimensions [mm]									Weights [kg]		Ship. vol. [m³]
	L1	B1	B2	B3	B4	H1	H2	H3	G	Net	Gross	
ALPHAx 15-50	130	60.5	60.5	44.5	44.5	35.8	103.5	52	G 1*	1.8	2.0	0.00364
ALPHAx 15-50 N	130	60.5	60.5	44.5	44.5	35.8	103.5	52	G 1*	1.8	2.0	0.00364

* UK version: G 1 1/2.

See product numbers and QR codes in section [Accessories](#).

TM05 1673 4111 - TM05 2713 0412 - TM05 2683 0312

TM05 2364 5011

ALPHAx 15-60 (N)

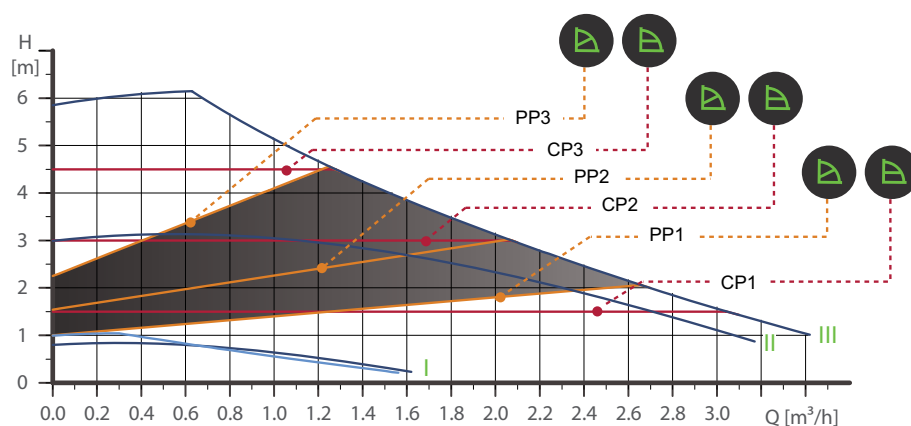

Note: The test was commissioned and paid for by Grundfos Holding A/S.

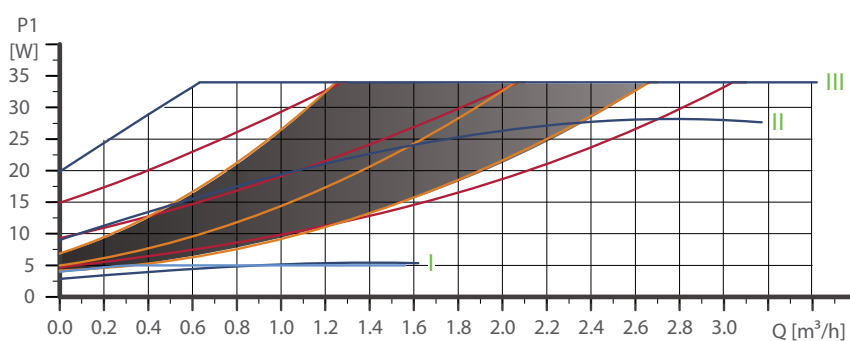

Speed	P1 [W]	$I_{1/1}$ [A]
AUTO _{ADAPT}	4-34	0.04 - 0.32
Min.	3	0.04
Max.	34	0.32

The pump incorporates overload protection.

Connections: See [Unions and valve kits](#), page 29.

System pressure: Max. 1.0 MPa (10 bar).

Liquid temperature: 2-110 °C (TF 110).

Also available with: Stainless-steel pump housing, type N.

Specific EEL: ≤ 0.17 .

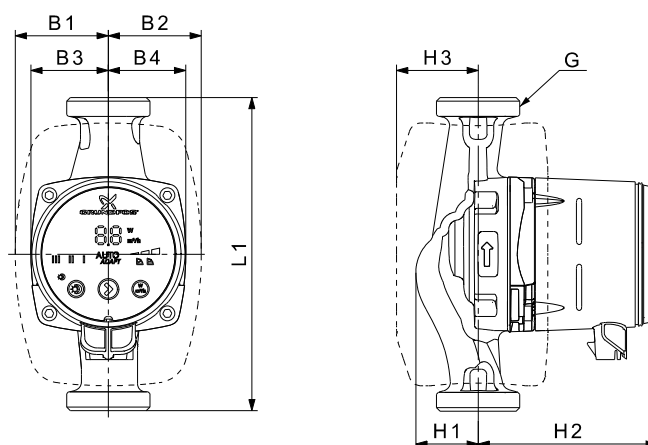

Pump type	Dimensions [mm]									Weights [kg]		Ship. vol. [m ³]
	L1	B1	B2	B3	B4	H1	H2	H3	G	Net	Gross	
ALPHAx 15-60	130	60.5	60.5	44.5	44.5	35.8	103.5	52	G 1*	1.8	2.0	0.00364
ALPHAx 15-60 N	130	60.5	60.5	44.5	44.5	35.8	103.5	52	G 1*	1.8	2.0	0.00364

* UK version: G 1 1/2.

See product numbers and QR codes in section [Accessories](#).

TM05 1674 4111 - TM05 2714 0412 - TM05 2683 0312

TM05 2364 5011

ALPHAx 15-80 (N)

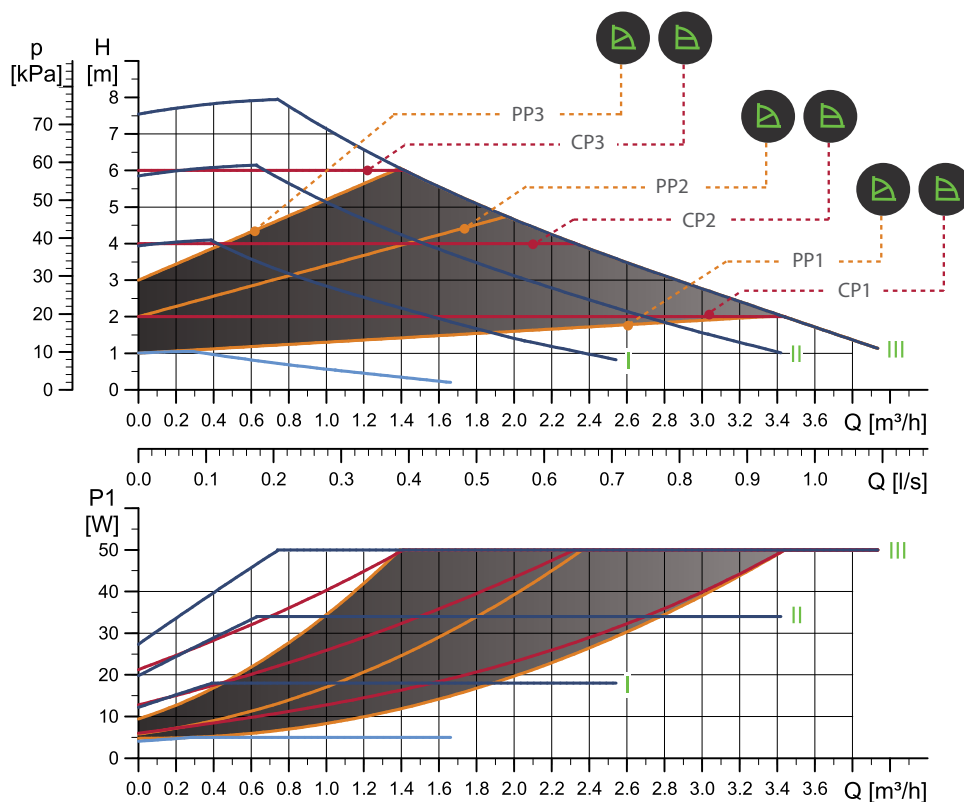

TM06 1285 2114

Speed	P1 [W]	I _{1/1} [A]
AUTO _{ADAPT}	4-50	0.04 - 0.44
Min.	3	0.04
Max.	50	0.44

Connections: See [Unions and valve kits](#), page 29.

System pressure: Max. 1.0 MPa (10 bar).

Liquid temperature: 2-110 °C (TF 110).

Specific EEI: ≤ 0.18.

The pump incorporates overload protection.

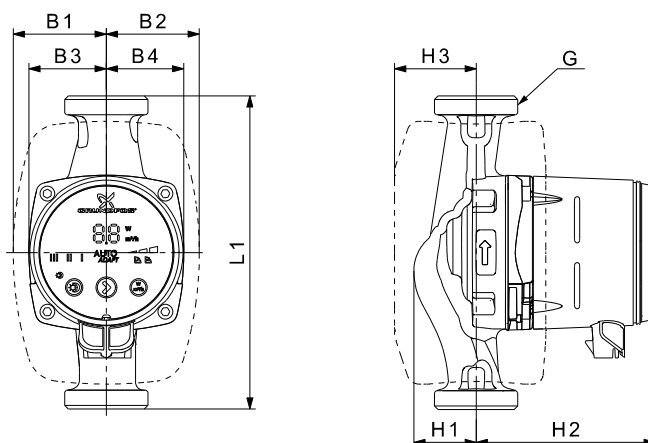

TM05 2364 5011

Pump type	Dimensions [mm]									Weights [kg]		Ship. vol. [m³]
	L1	B1	B2	B3	B4	H1	H2	H3	G	Net	Gross	
ALPHAx 15-80	130	60.5	60.5	44.5	44.5	35.8	103.5	52	G 1*	1.8	2.0	0.00364

* UK version: G 1 1/2.

See product numbers and QR codes in section [Accessories](#).

ALPHAx 25-40 (N)

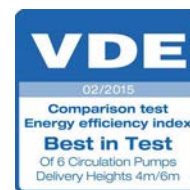
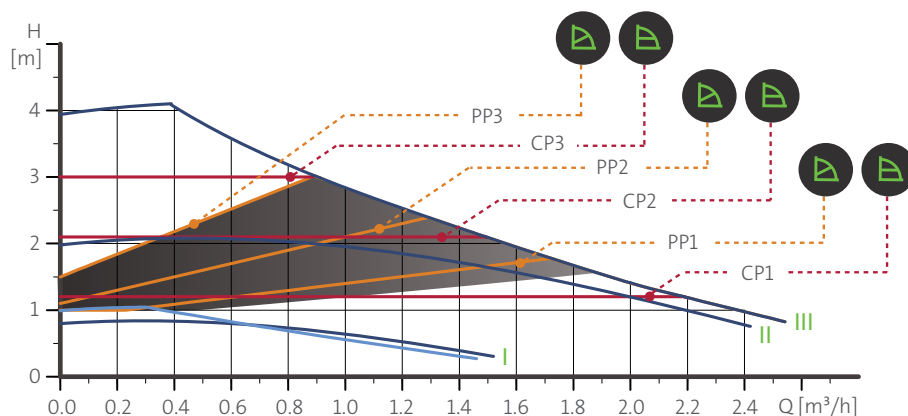

Note: The test was commissioned and paid for by Grundfos Holding A/S.

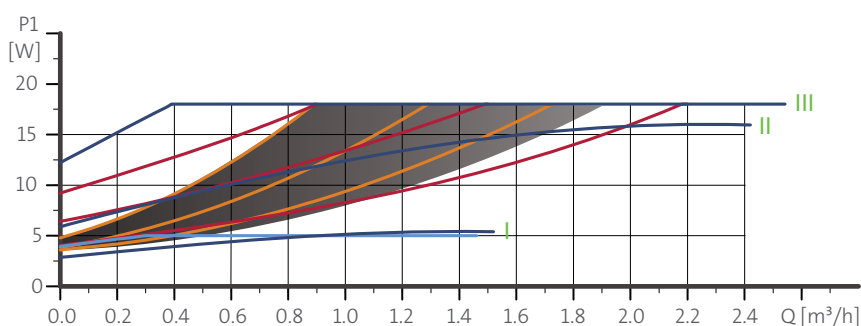

Speed	P1 [W]	I _{1/I1} [A]
AUTO _{ADAPT}	4-18	0.04 - 0.18
Min.	3	0.04
Max.	18	0.18

The pump incorporates overload protection.

Connections: See [Unions and valve kits](#), page 29.

System pressure: Max. 1.0 MPa (10 bar).

Liquid temperature: 2-110 °C (TF 110).

Also available with: Stainless-steel pump housing, type N.

Specific EEI: ≤ 0.15.

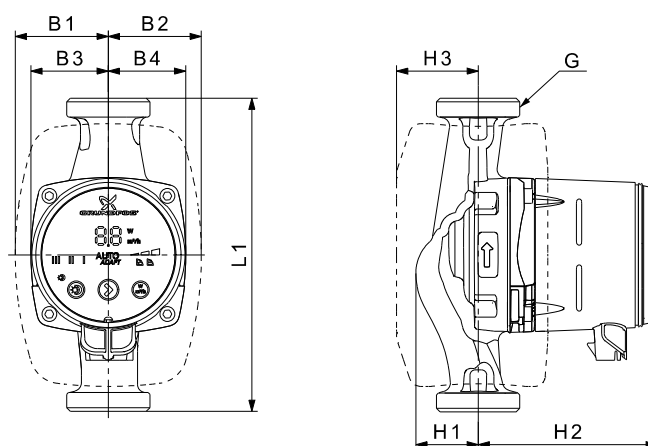

Pump type	Dimensions [mm]								Weights [kg]		Ship. vol. [m³]	
	L1	B1	B2	B3	B4	H1	H2	H3	G	Net		Gross
ALPHAx 25-40	130	60.5	60.5	44.5	44.5	35.8	103.5	52	G 1 1/2	1.8	2.0	0.00364
ALPHAx 25-40 N	130	60.5	60.5	44.5	44.5	36.8	103.5	52	G 1 1/2	1.8	2.0	0.00364
ALPHAx 25-40	180	60.5	60.5	44.5	44.5	35.9	103.5	52	G 1 1/2	1.8	2.0	0.00364
ALPHAx 25-40 N	180	60.5	60.5	44.5	44.5	36.9	103.5	52	G 1 1/2	1.8	2.0	0.00364

See product numbers and QR codes in section [Accessories](#).

TM05 1672 4111 - TM05 2712 0412 - TM05 2683 0312

TM05 2364 5011

ALPHAx 25-40 A

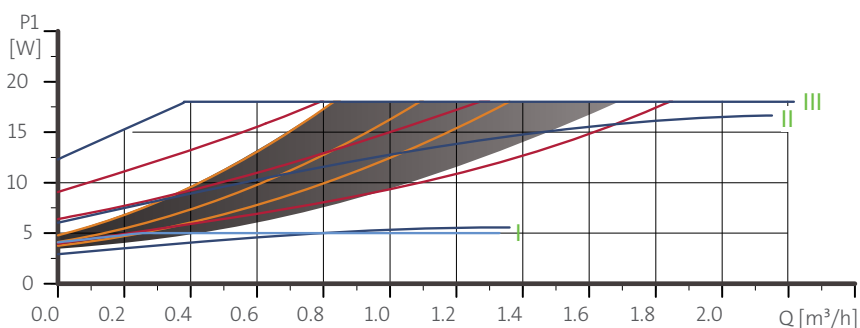
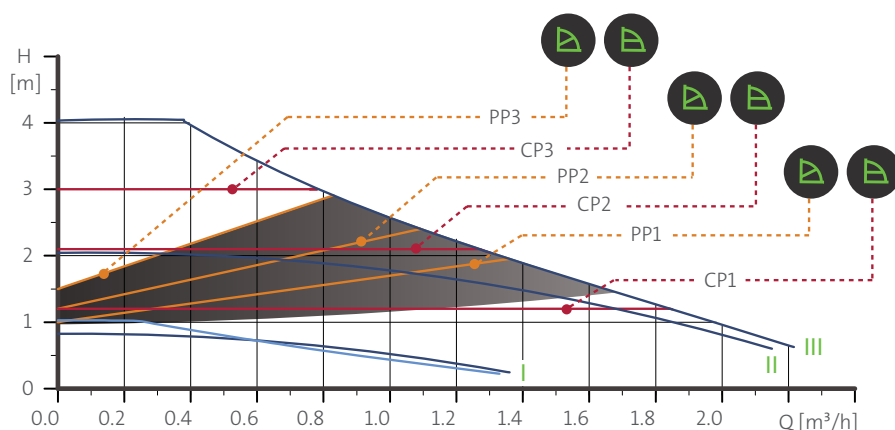

Speed	P1 [W]	$I_{1/1}$ [A]
AUTO_{ADAPT}	4-18	0.04 - 0.18
Min.	3	0.04
Max.	18	0.18

Connections: See [Unions and valve kits](#), page 29.

System pressure: Max. 1.0 MPa (10 bar).

Liquid temperature: 2-110 °C (TF 110).

Specific EEI: ≤ 0.18 .

The pump incorporates overload protection.

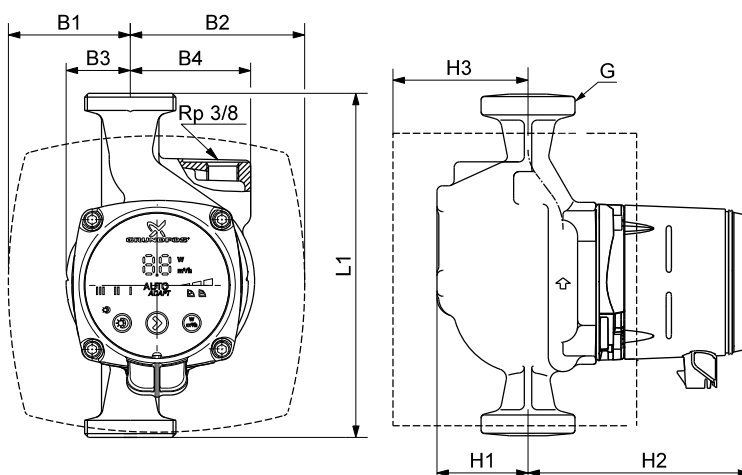

Pump type	Dimensions [mm]									Weights [kg]		Ship. vol. [m³]
	L1	B1	B2	B3	B4	H1	H2	H3	G	Net	Gross	
ALPHAx 25-40 A	180	63.5	98	32	63	50	124	81	G 1 1/2	2.8	3.0	0.00396

See product numbers and QR codes in section [Accessories](#).

TM05 2016 4211 - TM05 2715 0412 - TM05 2683 0312

TM05 2574 0212

ALPHAx 25-50 (N)

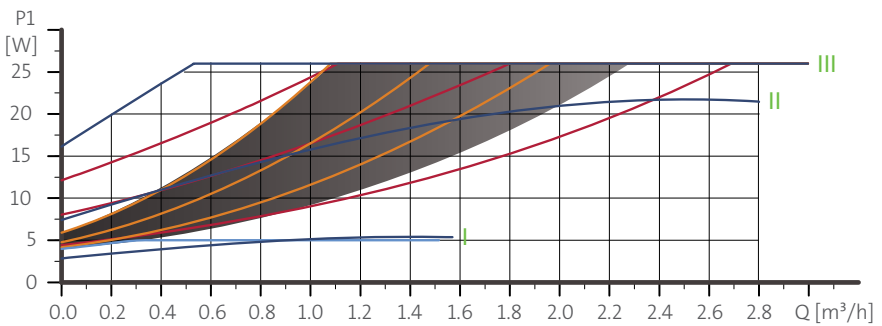
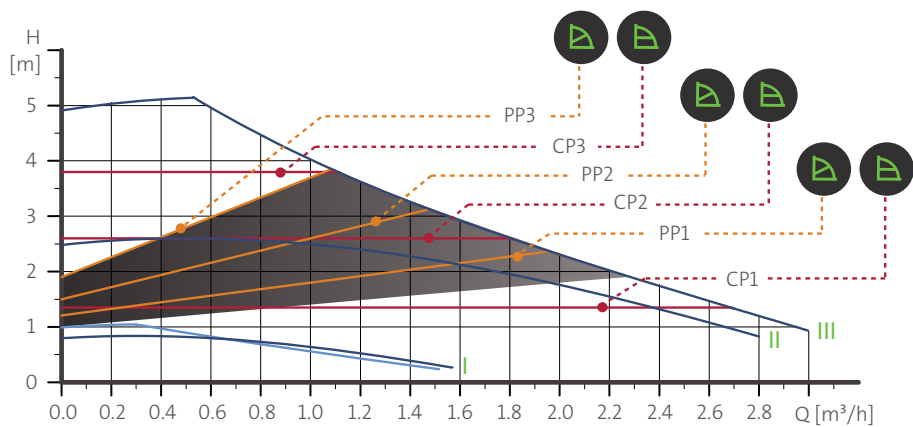

Speed	P1 [W]	I _{1/1} [A]
AUTO _{ADAPT}	4-26	0.04 - 0.24
Min.	3	0.04
Max.	26	0.24

Connections: See [Unions and valve kits](#), page 29.
 System pressure: Max. 1.0 MPa (10 bar).
 Liquid temperature: 2-110 °C (TF 110).
 Also available with: Stainless-steel pump housing, type N.
 Specific EEL: ≤ 0.16.

The pump incorporates overload protection.

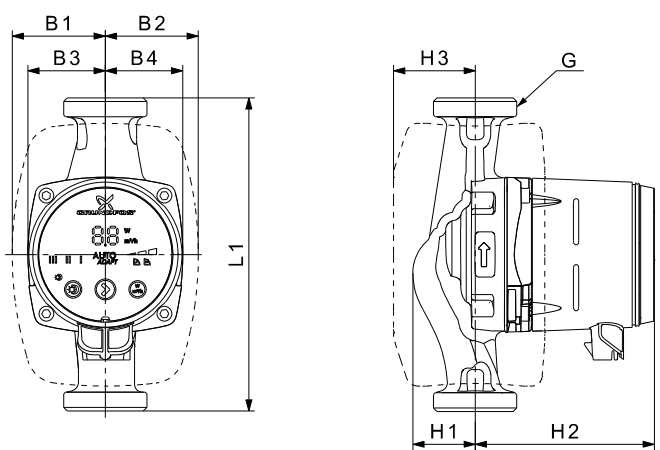

Pump type	Dimensions [mm]								Weights [kg]		Ship. vol. [m³]	
	L1	B1	B2	B3	B4	H1	H2	H3	G	Net		Gross
ALPHAx 25-50	130	60.5	60.5	44.5	44.5	35.8	103.5	52	G 1 1/2	1.8	2.0	0.00364
ALPHAx 25-50 N	130	60.5	60.5	44.5	44.5	36.8	103.5	52	G 1 1/2	1.8	2.0	0.00364
ALPHAx 25-50	180	60.5	60.5	44.5	44.5	35.9	103.5	52	G 1 1/2	1.8	2.0	0.00364
ALPHAx 25-50 N	180	60.5	60.5	44.5	44.5	36.9	103.5	52	G 1 1/2	1.8	2.0	0.00364

See product numbers and QR codes in section [Accessories](#).

TM05 1673 4111 - TM05 2713 0412 - TM05 2683 0312

TM05 2364 5011

ALPHAx 25-60 (N)

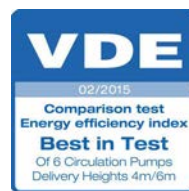
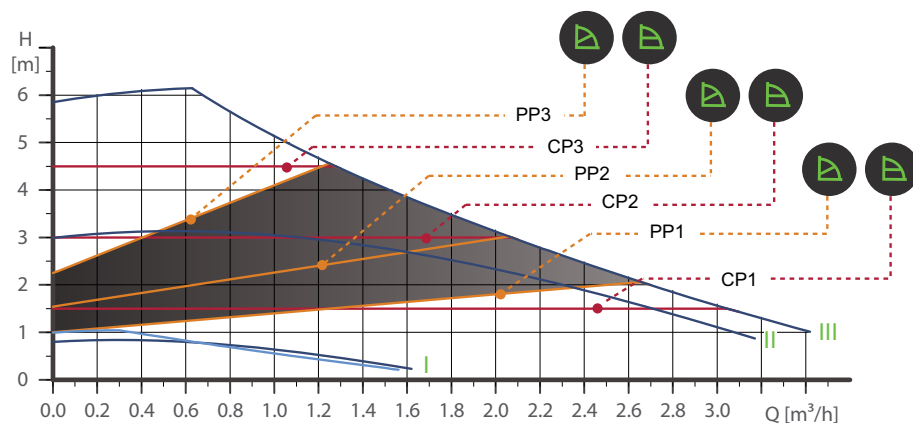

Note: The test was commissioned and paid for by Grundfos Holding A/S.

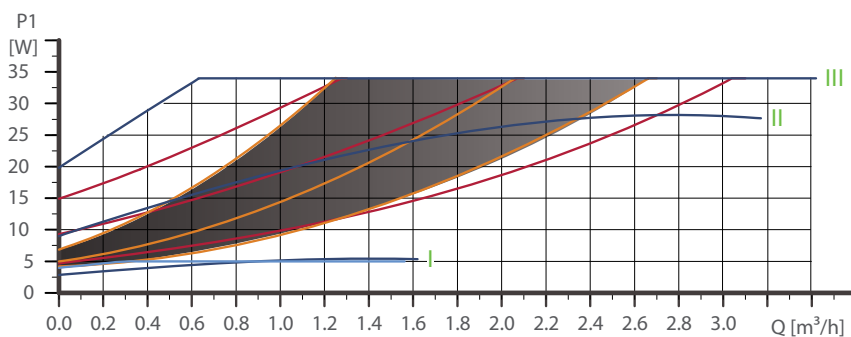

Speed	P1 [W]	$I_{1/1}$ [A]
AUTO _{ADAPT}	4-34	0.04 - 0.32
Min.	3	0.04
Max.	34	0.32

The pump incorporates overload protection.

Connections: See [Unions and valve kits](#), page 29.

System pressure: Max. 1.0 MPa (10 bar).

Liquid temperature: 2-110 °C (TF 110).

Also available with: Stainless-steel pump housing, type N.

Specific EEI: ≤ 0.17.

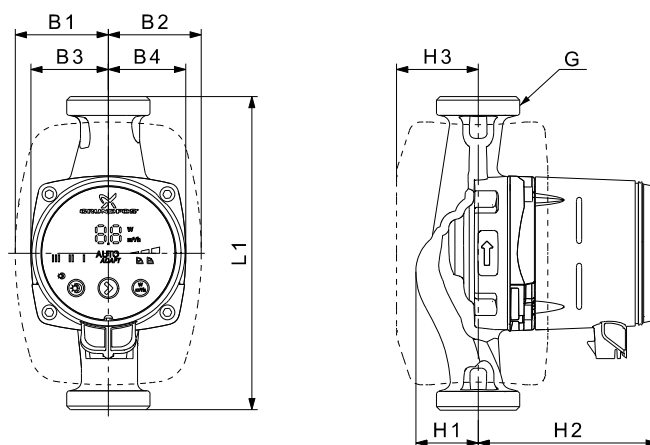

Pump type	Dimensions [mm]								Weights [kg]		Ship. vol. [m ³]	
	L1	B1	B2	B3	B4	H1	H2	H3	G	Net		Gross
ALPHAx 25-60	130	60.5	60.5	44.5	44.5	35.8	103.5	52	G 1 1/2	1.8	2.0	0.00364
ALPHAx 25-60 N	130	60.5	60.5	44.5	44.5	36.8	103.5	52	G 1 1/2	1.8	2.0	0.00364
ALPHAx 25-60	180	60.5	60.5	44.5	44.5	35.9	103.5	52	G 1 1/2	1.8	2.0	0.00364
ALPHAx 25-60 N	180	60.5	60.5	44.5	44.5	36.9	103.5	52	G 1 1/2	1.8	2.0	0.00364

See product numbers and QR codes in section [Accessories](#).

TM05 1674 4111 - TM05 2714 0412 - TM05 2683 0312

TM05 2364 5011

ALPHAx 25-60 A

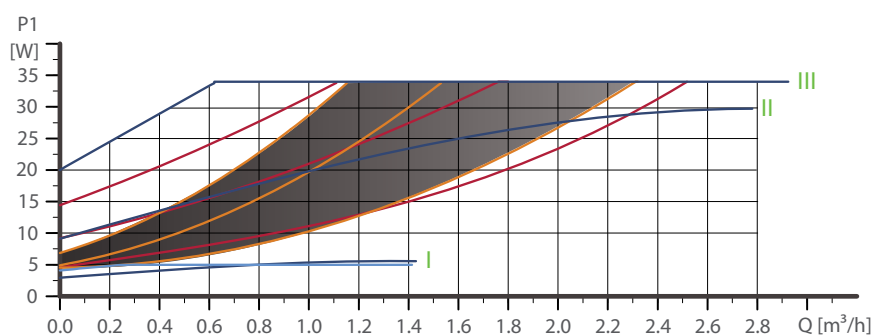
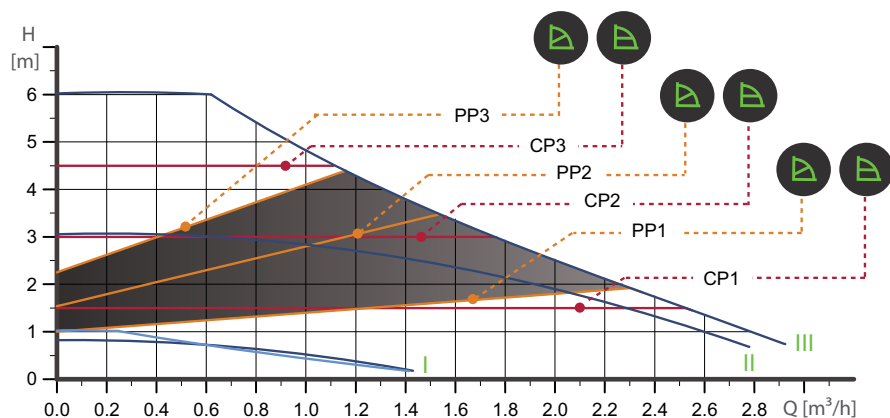

Speed	P1 [W]	I _{1/1} [A]
AUTO_{ADAPT}	4-34	0.04 - 0.32
Min.	3	0.04
Max.	34	0.32

Connections: See [Unions and valve kits](#), page 29.

System pressure: Max. 1.0 MPa (10 bar).

Liquid temperature: 2-110 °C (TF 110).

Specific EEI: ≤ 0.20.

The pump incorporates overload protection.

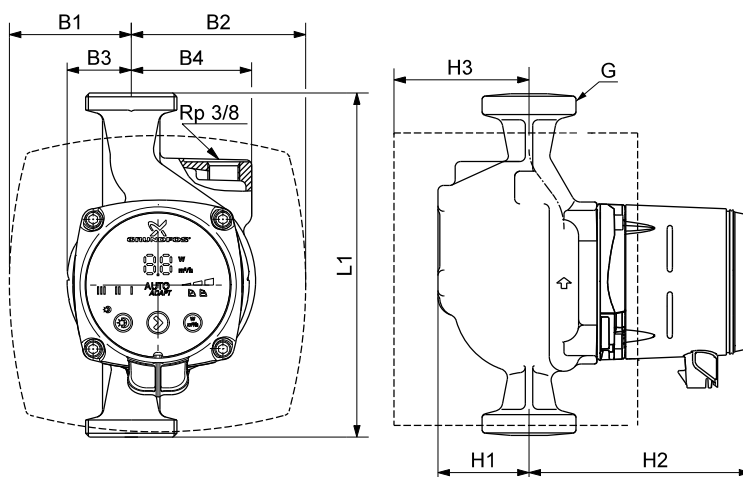

Pump type	Dimensions [mm]								Weights [kg]		Ship. vol. [m ³]	
	L1	B1	B2	B3	B4	H1	H2	H3	G	Net		Gross
ALPHAx 25-60 A	180	63.5	98	32	63	50	124	81	G 1 1/2	2.8	3.0	0.00396

See product numbers and QR codes in section [Accessories](#).

TM05 2017 4211 - TM05 2682 0312 - TM05 2683 0312

TM05 2574 0212

ALPHAx 25-80 (N)

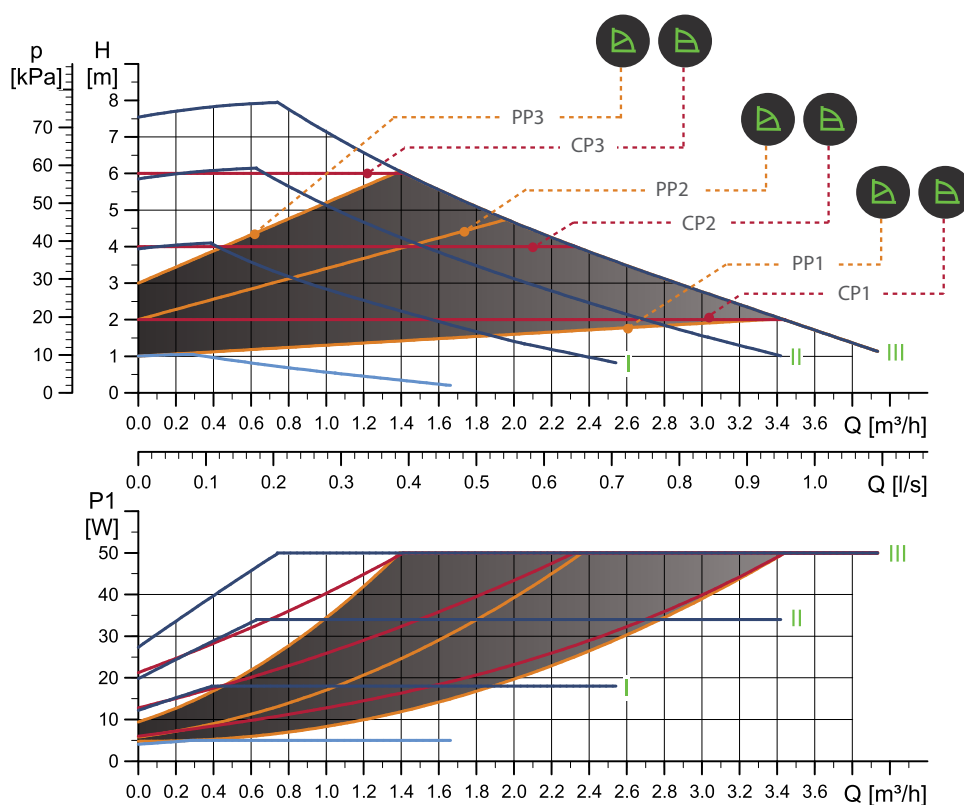

TM06 1285 2114

Speed	P1 [W]	I _{1/1} [A]
AUTO _{ADAPT}	4-50	0.04 - 0.44
Min.	3	0.04
Max.	50	0.44

The pump incorporates overload protection.

Connections: See [Unions and valve kits](#), page 29.

System pressure: Max. 1.0 MPa (10 bar).

Liquid temperature: 2-110 °C (TF 110).

Also available with: Stainless-steel pump housing, type N.

Specific EEI: ≤ 0.18.

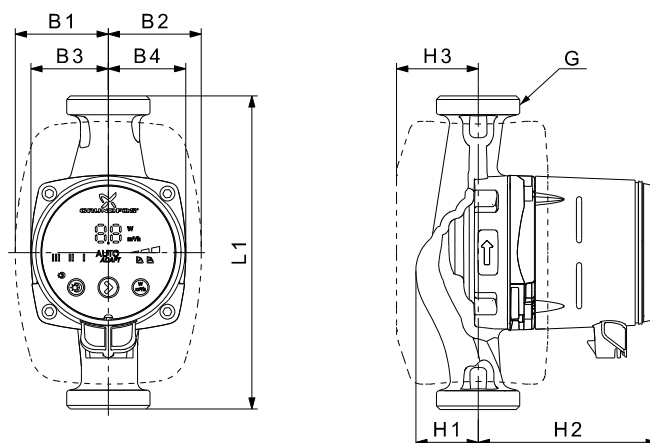

TM05 2364 5011

Pump type	Dimensions [mm]						Weights [kg]		Ship. vol. [m³]			
	L1	B1	B2	B3	B4	H1	H2	H3		G	Net	Gross
ALPHAx 25-80	130	60.5	60.5	44.5	44.5	35.8	103.5	52	G 1 1/2	1.8	2.0	0.00364
ALPHAx 25-80 N	130	60.5	60.5	44.5	44.5	36.8	103.5	52	G 1 1/2	1.8	2.0	0.00364
ALPHAx 25-80	180	60.5	60.5	44.5	44.5	35.9	103.5	52	G 1 1/2	1.8	2.0	0.00364
ALPHAx 25-80 N	180	60.5	60.5	44.5	44.5	36.9	103.5	52	G 1 1/2	1.8	2.0	0.00364

See product numbers and QR codes in section [Accessories](#).

ALPHAx 32-40 (N)

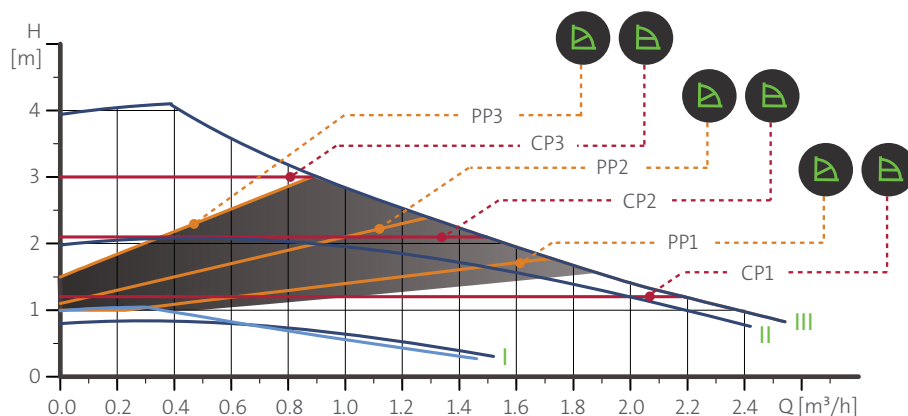

Note: The test was commissioned and paid for by Grundfos Holding A/S.

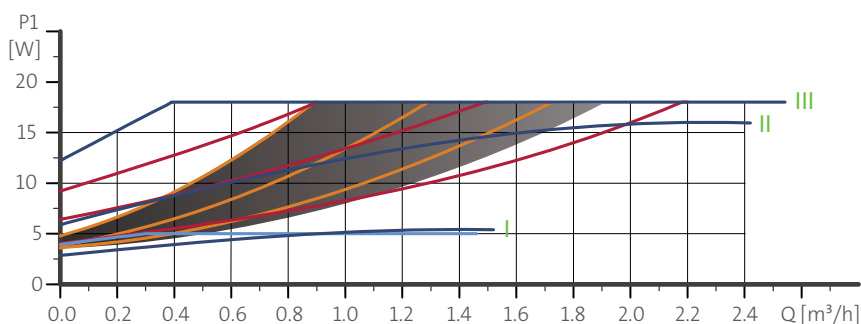

Speed	P1 [W]	I _{1/1} [A]
AUTO _{ADAPT}	4-18	0.04 - 0.18
Min.	3	0.04
Max.	18	0.18

The pump incorporates overload protection.

Connections: See [Unions and valve kits](#), page 29.

System pressure: Max. 1.0 MPa (10 bar).

Liquid temperature: 2-110 °C (TF 110).

Also available with: Stainless-steel pump housing, type N.

Specific EEI: ≤ 0.15.

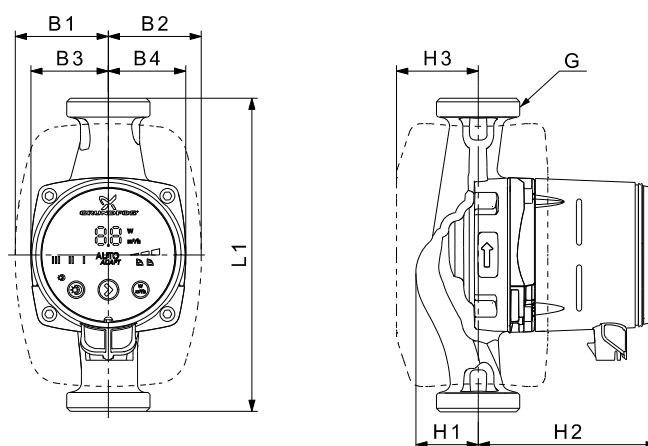

Pump type	Dimensions [mm]									Weights [kg]		Ship. vol. [m³]
	L1	B1	B2	B3	B4	H1	H2	H3	G	Net	Gross	
ALPHAx 32-40	180	60.5	60.5	44.5	44.5	35.9	103.5	52	G 2	1.8	2.0	0.00364
ALPHAx 32-40 N	180	60.5	60.5	44.5	44.5	36.9	103.5	52	G 2	1.8	2.0	0.00364

See product numbers and QR codes in section [Accessories](#).

TM05 1672 4111 - TM05 2712 0412 - TM05 2683 0312

TM05 2364 5011

ALPHAx 32-50 (N)

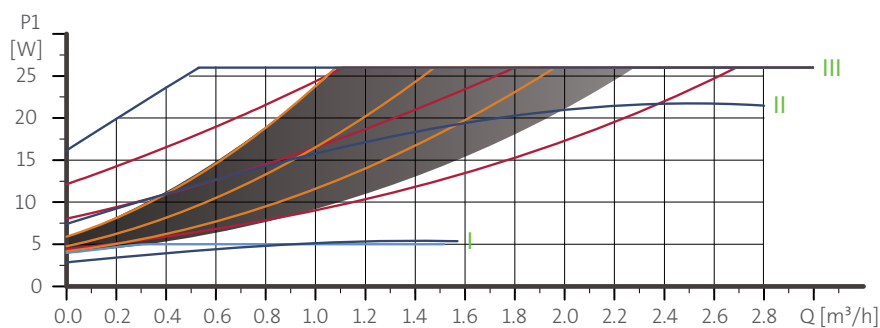
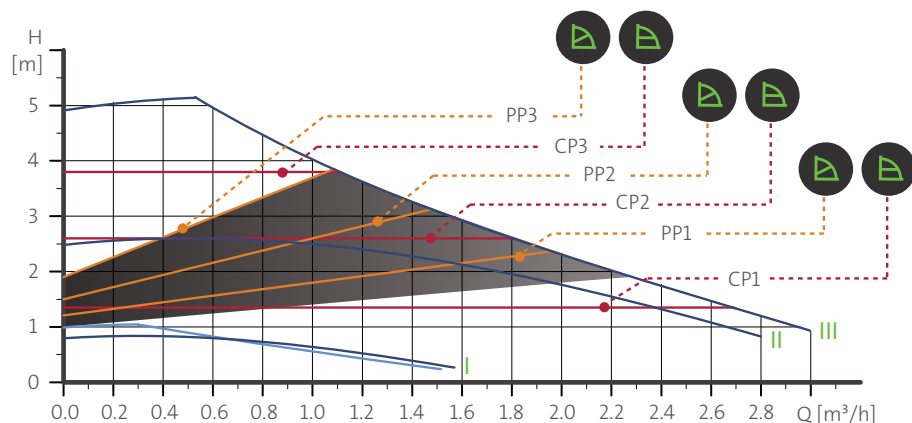

Speed	P1 [W]	$I_{1/1}$ [A]
AUTO_{ADAPT}	4-26	0.04 - 0.24
Min.	3	0.04
Max.	26	0.24

The pump incorporates overload protection.

Connections: See [Unions and valve kits](#), page 29.

System pressure: Max. 1.0 MPa (10 bar).

Liquid temperature: 2-110 °C (TF 110).

Also available with: Stainless-steel pump housing, type N.

Specific EEI: ≤ 0.16 .

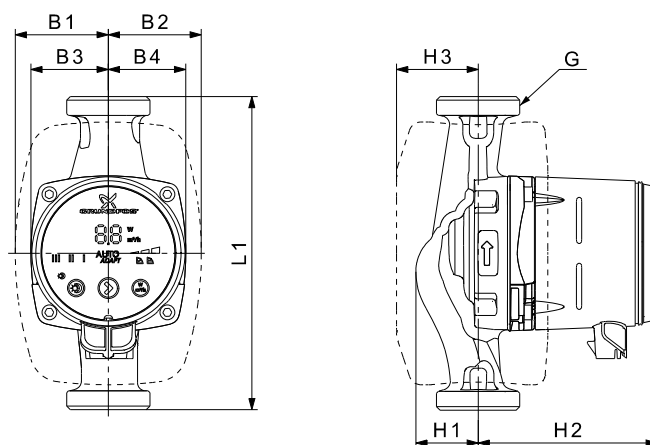

Pump type	Dimensions [mm]									Weights [kg]		Ship. vol. [m³]
	L1	B1	B2	B3	B4	H1	H2	H3	G	Net	Gross	
ALPHAx 32-50	180	60.5	60.5	44.5	44.5	35.9	103.5	52	G 2	1.8	2.0	0.00364
ALPHAx 32-50 N	180	60.5	60.5	44.5	44.5	36.9	103.5	52	G 2	1.8	2.0	0.00364

See product numbers and QR codes in section [Accessories](#).

TM05 1673 4111 - TM05 2713 0412 - TM05 2683 0312

TM05 2364 5011

ALPHAx 32-60 (N)

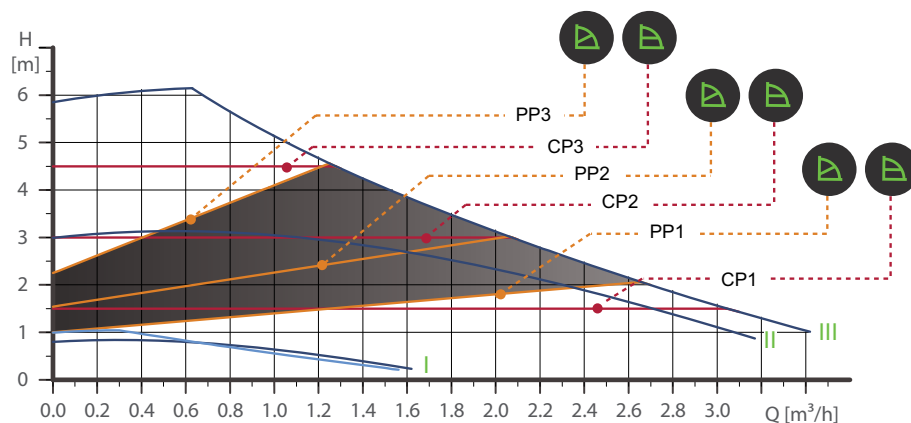

Note: The test was commissioned and paid for by Grundfos Holding A/S.

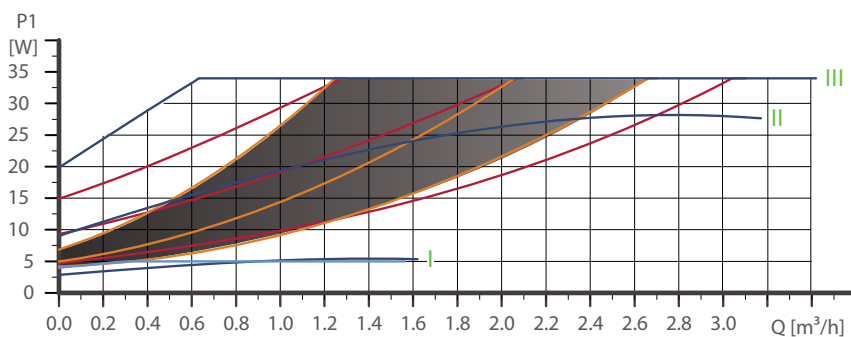

Speed	P1 [W]	$I_{1/1}$ [A]
AUTO _{ADAPT}	4-34	0.04 - 0.32
Min.	3	0.04
Max.	34	0.32

The pump incorporates overload protection.

Connections: See [Unions and valve kits](#), page 29.

System pressure: Max. 1.0 MPa (10 bar).

Liquid temperature: 2-110 °C (TF 110).

Also available with: Stainless-steel pump housing, type N.

Specific EEI: ≤ 0.17 .

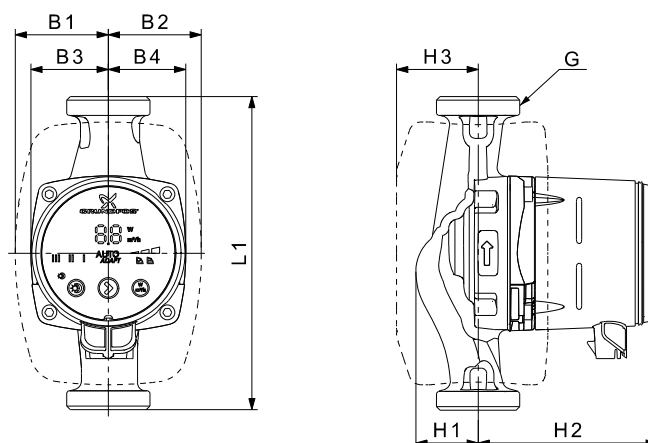

Pump type	Dimensions [mm]									Weights [kg]		Ship. vol. [m ³]
	L1	B1	B2	B3	B4	H1	H2	H3	G	Net	Gross	
ALPHAx 32-60	180	60.5	60.5	44.5	44.5	35.9	103.5	52	G 2	1.8	2.0	0.00364
ALPHAx 32-60 N	180	60.5	60.5	44.5	44.5	36.9	103.5	52	G 2	1.8	2.0	0.00364

See product numbers and QR codes in section [Accessories](#).

TM05 1674 4111 - TM05 2714 0412 - TM05 2683 0312

TM05 2364 5011

ALPHAx 32-80 (N)

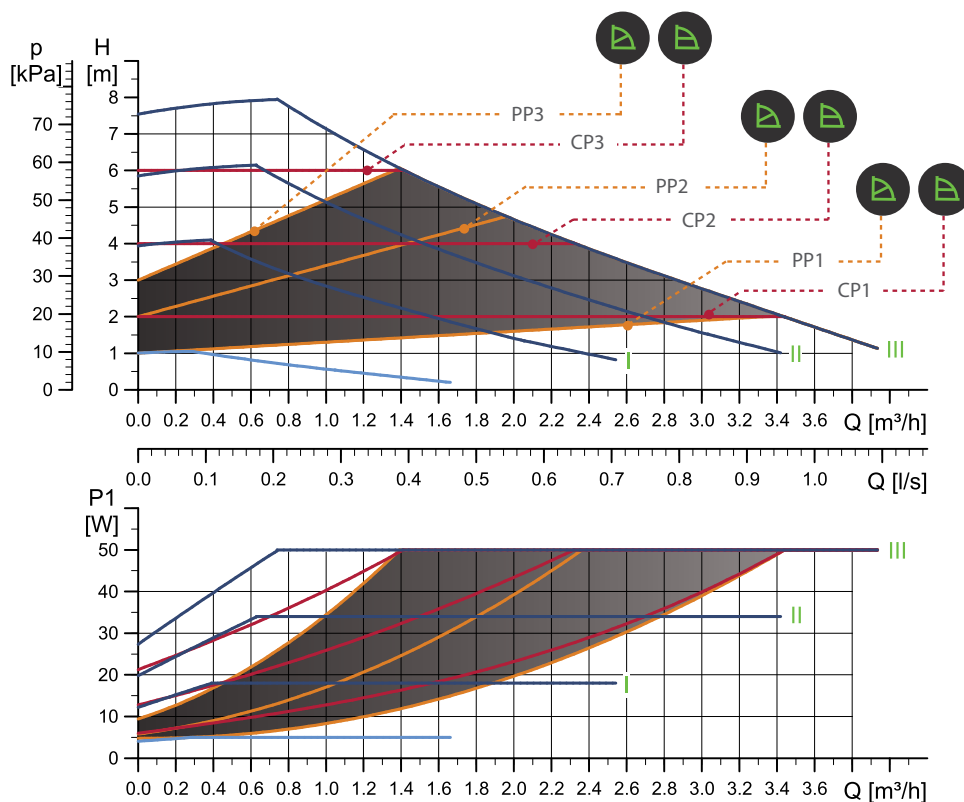

TM06 1285 2114

Speed	P1 [W]	I _{1/1} [A]
AUTO _{ADAPT}	4-50	0.04 - 0.44
Min.	3	0.04
Max.	50	0.44

The pump incorporates overload protection.

Connections: See [Unions and valve kits](#), page 29.

System pressure: Max. 1.0 MPa (10 bar).

Liquid temperature: 2-110 °C (TF 110).

Also available with: Stainless-steel pump housing, type N.

Specific EEI: ≤ 0.18.

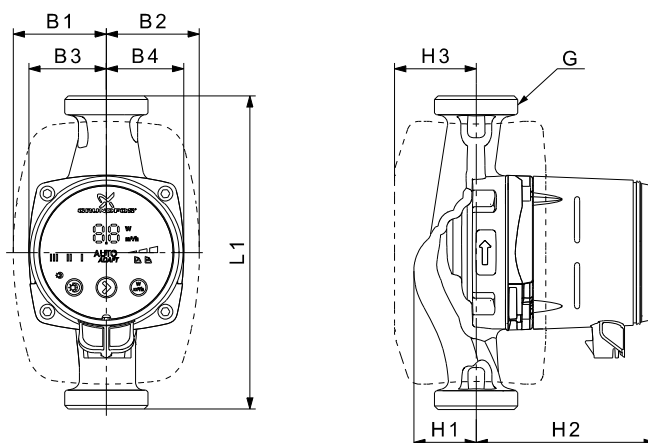

TM05 2364 5011

Pump type	Dimensions [mm]					Weights [kg]				Ship. vol. [m ³]		
	L1	B1	B2	B3	B4	H1	H2	H3	G		Net	Gross
ALPHAx 32-80	130	60.5	60.5	44.5	44.5	35.8	103.5	52	G 2	1.8	2.0	0.00364
ALPHAx 32-80 N	130	60.5	60.5	44.5	44.5	36.8	103.5	52	G 2	1.8	2.0	0.00364
ALPHAx 32-80	180	60.5	60.5	44.5	44.5	35.9	103.5	52	G 2	1.8	2.0	0.00364
ALPHAx 32-80 N	180	60.5	60.5	44.5	44.5	36.9	103.5	52	G 2	1.8	2.0	0.00364

See product numbers and QR codes in section [Accessories](#).

7. Accessories

Unions and valve kits

		Product numbers, unions														
ALPHAx	Connection	Rp			R		Rp			mm		mm				
		3/4	1	1 1/4	1	1 1/4	3/4	1	1 1/4	Ø22	Ø28	Ø15	Ø18	Ø22	Ø28	Ø42
15-xx*	G 1	•														
15-xx N*		•														
25-xx	G 1 1/2	529921	529922	529821	529925	529924										
25-xx N		529971	529972				519805	519806	519807	519808	519809			529977	529978	529979
32-xx	G 2		509921	509922												
32-xx N				509971												

* When ordering for UK versions, use product numbers for 25-xx (G 1 1/2).

• Available on request.

Insulating kits

The pump is supplied with two insulating shells.

The insulation thickness of the insulating shells corresponds to the nominal diameter of the pump.

The insulating kit, which is tailored to the individual pump type, encloses the entire pump housing. The two insulating shells are easy to fit around the pump.

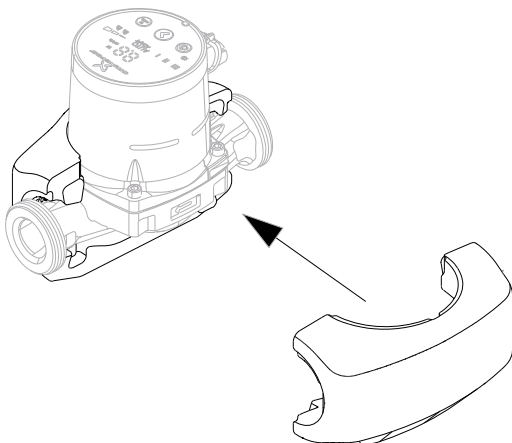

TM05 2523 0112

Fig. 26 Insulating shells

Pump type	Product number
ALPHAx XX-XX 130	98091786
ALPHAx XX-XX 180	98091787
ALPHAx XX-XX A	505822

ALPHA plugs



TM05 3073 0612

Fig. 27 ALPHA plugs



Pos.	Description	Product number
1	ALPHA plug, standard plug connection	98284561
2	ALPHA angle plug, standard angle plug connection	98610291
3	ALPHA plug, 90 ° bend, including 4 m cable	96884669

Grundfos offers a special cable with an active built-in NTC protection circuit, which will reduce possible inrush currents. To be used in case of e.g. poor quality of relay components that are sensitive to inrush current.

ALPHAx for the German market

Note: Click on the product number and go directly to the performance curve in Grundfos Product Center (GPC).

Pump type	Port-to-port length [mm]	Connection	Product number (incl. insulating shells)	Insulating kit (separate)	Data sheet Page	QR code for GPC
ALPHA2 15-40	130	G 1	97914899	98091786	15	
ALPHA3 15-40	130	G 1	98888290	98091786	15	
ALPHA2 15-60	130	G 1	97914900	98091786	17	
ALPHA3 15-60	130	G 1	98888311	98091786	17	
ALPHA2 15-80	130	G 1	98676767	98091786	18	
ALPHA3 15-80	130	G 1	98888312	98091786	18	
ALPHA2 25-40	130	G 1 1/2	97914901	98091786	19	
ALPHA3 25-40	130	G 1 1/2	98888313	98091786	19	
ALPHA2 25-40 N	130	G 1 1/2	97914909	98091786	19	
ALPHA3 25-40 N	130	G 1 1/2	98888325	98091786	19	
ALPHA2 25-60	130	G 1 1/2	97914902	98091786	22	
ALPHA3 25-60	130	G 1 1/2	98888314	98091786	22	
ALPHA2 25-60 N	130	G 1 1/2	97914910	98091786	22	
ALPHA3 25-60 N	130	G 1 1/2	98888326	98091786	22	







Pump type	Port-to-port length [mm]	Connection	Product number (incl. insulating shells)	Insulating kit (separate)	Data sheet Page	QR code for GPC
ALPHA2 25-40	180	G 1 1/2	97914903	98091787	19	
ALPHA3 25-40	180	G 1 1/2	98888317	98091787	19	
ALPHA2 25-40 N	180	G 1 1/2	97914911	98091787	19	
ALPHA3 25-40 N	180	G 1 1/2	98888328	98091787	19	
ALPHA2 25-40 A	180	G 1 1/2	97914904	505822	20	
ALPHA3 25-40 A	180	G 1 1/2	98888318	505822	20	
ALPHA2 25-60	180	G 1 1/2	97914905	505822	23	
ALPHA3 25-60	180	G 1 1/2	98888314	505822	23	
ALPHA2 25-60 A	180	G 1 1/2	97914906	505822	23	
ALPHA3 25-60 A	180	G 1 1/2	98888321	505822	23	
ALPHA2 25-80	130	G 1 1/2	98649755	98091786	24	
ALPHA3 25-80	130	G 1 1/2	98888315	98091786	24	
ALPHA2 25-80 N	130	G 1 1/2	98676785	98091786	24	
ALPHA3 25-80 N	130	G 1 1/2	98888327	98091786	24	
ALPHA2 25-80	180	G 1 1/2	98649758	98091787	24	

Pump type	Port-to-port length [mm]	Connection	Product number (incl. insulating shells)	Insulating kit (separate)	Data sheet Page	QR code for GPC
ALPHA3 25-80	180	G 1 1/2	98888320	98091787	24	
ALPHA2 25-80 N	180	G 1 1/2	98676786	98091787	24	
ALPHA3 25-80 N	180	G 1 1/2	98888331	98091787	24	
ALPHA2 32-40	180	G 2	97914907	98091787	25	
ALPHA3 32-40	180	G 2	98888322	98091787	25	
ALPHA2 32-40 N	180	G 2	97914913	98091787	25	
ALPHA3 32-40 N	180	G 2	98888332	98091787	25	
ALPHA2 32-60	180	G 2	97914908	98091787	27	
ALPHA3 32-60	180	G 2	98888323	98091787	27	
ALPHA2 32-60 N	180	G 2	97914914	98091787	27	
ALPHA3 32-60 N	180	G 2	98888333	98091787	27	
ALPHA2 32-80	180	G 2	98676768	98091787	27	
ALPHA3 32-80	180	G 2	98888324	98091787	27	
ALPHA2 32-80 N	180	G 2	98676787	98091787	27	
ALPHA3 32-80 N	180	G 2	98888334	98091787	27	

ALPHAx for the international market

Note: Click on the product number and go directly to the performance curve in Grundfos Product Center (GPC).

Pump type	Port-to-port length [mm]	Connection	Product number (incl. insulating shells)	Insulating kit (separate)	Data sheet Page	QR code for GPC
ALPHA2 15-40	130	G 1	97993192	98091786	15	
ALPHA3 15-40	130	G 1	98890717	98091786	15	
ALPHA2 15-50	130	G 1	97993193	98091786	16	
ALPHA3 15-50	130	G 1	98890746	98091786	16	
ALPHA2 15-60	130	G 1	97993194	98091786	17	
ALPHA3 15-60	130	G 1	98890747	98091786	17	
ALPHA2 15-80	130	G 1	98676765	98091786	17	
ALPHA3 15-80	130	G 1	98890748	98091786	17	
ALPHA2 25-40	130	G 1 1/2	97993195	98091786	19	
ALPHA3 25-40	130	G 1 1/2	98890750	98091786	19	
ALPHA2 25-40 N	130	G 1 1/2	97993206	98091786	19	
ALPHA3 25-40 N	130	G 1 1/2	98890834	98091786	19	
ALPHA2 25-40	180	G 1 1/2	97704990	98091787	19	
ALPHA3 25-40	180	G 1 1/2	98890766	98091787	19	

Pump type	Port-to-port length [mm]	Connection	Product number (incl. insulating shells)	Insulating kit (separate)	Data sheet Page	QR code for GPC
ALPHA2 25-40 N	180	G 1 1/2	97993209	98091787	19	
ALPHA3 25-40 N	180	G 1 1/2	98890839	98091787	19	
ALPHA2 25-40 A	180	G 1 1/2	97993199	98091787	19	
ALPHA3 25-40 A	180	G 1 1/2	98890767	98091787	19	
ALPHA2 25-50	130	G 1 1/2	97993196	98091786	21	
ALPHA3 25-50	130	G 1 1/2	98890768	98091786	21	
ALPHA2 25-50 N	130	G 1 1/2	97993207	98091786	21	
ALPHA3 25-50 N	130	G 1 1/2	98890836	98091786	21	
ALPHA2 25-50	180	G 1 1/2	97993200	98091787	21	
ALPHA3 25-50	180	G 1 1/2	98890768	98091787	21	
ALPHA2 25-50 N	180	G 1 1/2	97993210	98091787	21	
ALPHA3 25-50 N	180	G 1 1/2	98890851	98091787	21	
ALPHA2 25-60	130	G 1 1/2	97993197	98091786	22	
ALPHA3 25-60	130	G 1 1/2	98890762	98091786	22	
ALPHA2 25-60 N	130	G 1 1/2	97993208	98091786	22	









Pump type	Port-to-port length [mm]	Connection	Product number (incl. insulating shells)	Insulating kit (separate)	Data sheet Page	QR code for GPC
ALPHA3 25-60 N	130	G 1 1/2	98890837	98091786	22	
ALPHA2 25-60	180	G 1 1/2	97993201	98091787	22	
ALPHA3 25-60	180	G 1 1/2	98890769	98091787	22	
ALPHA2 25-60 N	180	G 1 1/2	97993211	98091787	22	
ALPHA3 25-60 N	180	G 1 1/2	98890853	98091787	22	
ALPHA2 25-60 A	180	G 1 1/2	97993202	505822	23	
ALPHA3 25-60 A	180	G 1 1/2	98890781	505822	23	
ALPHA2 25-80	130	G 1 1/2	98649753	98091786	24	
ALPHA3 25-80	130	G 1 1/2	98890764	98091786	24	
ALPHA2 25-80 N	130	G 1 1/2	98676782	98091786	24	
ALPHA3 25-80 N	130	G 1 1/2	98890838	98091786	24	
ALPHA2 25-80	180	G 1 1/2	98649757	98091787	24	
ALPHA3 25-80	180	G 1 1/2	98890770	98091787	24	
ALPHA2 25-80 N	180	G 1 1/2	98676783	98091787	24	
ALPHA3 25-80 N	180	G 1 1/2	98890854	98091787	24	

Pump type	Port-to-port length [mm]	Connection	Product number (incl. insulating shells)	Insulating kit (separate)	Data sheet Page	QR code for GPC
ALPHA2 32-40	180	G 2	97993203	98091787	25	
ALPHA3 32-40	180	G 2	98890783	98091787	25	
ALPHA2 32-40 N	180	G 2	97993212	98091787	25	
ALPHA3 32-40 N	180	G 2	98890855	98091787	25	
ALPHA2 32-50	180	G 2	97993204	98091787	26	
ALPHA3 32-50	180	G 2	98890784	98091787	26	
ALPHA2 32-50 N	180	G 2	97993213	98091787	26	
ALPHA3 32-50 N	180	G 2	98890856	98091787	26	
ALPHA2 32-60	180	G 2	97993205	98091787	27	
ALPHA3 32-60	180	G 2	98890785	98091787	27	
ALPHA2 32-60 N	180	G 2	97993214	98091787	27	
ALPHA3 32-60 N	180	G 2	98890858	98091787	27	
ALPHA2 32-80	180	G 2	98676766	98091787	28	
ALPHA3 32-80	180	G 2	98890786	98091787	28	
ALPHA2 32-80 N	180	G 2	98676784	98091787	28	

Pump type	Port-to-port length [mm]	Connection	Product number (incl. insulating shells)	Insulating kit (separate)	Data sheet Page	QR code for GPC
ALPHA3 32-80 N	180	G 2	98890859	98091787	28	

ALPHAx for the UK market

Note: Click on the product number and go directly to the performance curve in Grundfos Product Center (GPC).

Pump type	Port-to-port length [mm]	Connection	Product number (incl. insulating shells)	Insulating kit (separate)	Data sheet Page	QR code for GPC
ALPHA2 15-50	130	G 1 1/2	97993149	98091786	16	
ALPHA2 15-60	130	G 1 1/2	97993150	98091786	17	
ALPHA3 15-50/60	130	G 1 1/2	98890833	98091786	17	
ALPHA2 15-50 N	130	G 1 1/2	97993151	98091786	16	
ALPHA2 15-60 N	130	G 1 1/2	97993152	98091786	17	
ALPHA3 15-50/60 N	130	G 1 1/2	98890876	98091786	17	
ALPHA2 15-80	130	G 1 1/2	98649774	98091786	17	
ALPHA3 15-80	130	G 1 1/2	98890831	98091786	17	



ALPHAx for the Austrian and Swiss markets

Note: Click on the product number and go directly to the performance curve in Grundfos Product Center (GPC).

Pump type	Port-to-port length [mm]	Connection	Product number (incl. insulating shells)	Insulating kit (separate)	Data sheet Page	QR code for GPC
ALPHA2 15-40	130	G 1	97993153	98091786	15	
ALPHA3 15-40	130	G 1	98890788	98091786	15	
ALPHA2 15-60	130	G 1	97993154	98091786	17	
ALPHA3 15-60	130	G 1	98890789	98091786	17	
ALPHA2 15-80	130	G 1	98676769	98091786	18	
ALPHA3 15-80	130	G 1	98890792	98091786	18	
ALPHA2 25-40	130	G 1 1/2	97993155	98091786	19	
ALPHA3 25-40	130	G 1 1/2	98890793	98091786	19	
ALPHA2 25-40 N	130	G 1 1/2	97993163	98091786	19	
ALPHA3 25-40 N	130	G 1 1/2	98890863	98091786	19	
ALPHA2 25-40	180	G 1 1/2	97993157	98091787	19	
ALPHA3 25-40	180	G 1 1/2	98890797	98091787	19	
ALPHA2 25-40 A	180	G 1 1/2	97993158	505822	20	
ALPHA3 25-40 A	180	G 1 1/2	98890799	505822	20	

Pump type	Port-to-port length [mm]	Connection	Product number (incl. insulating shells)	Insulating kit (separate)	Data sheet Page	QR code for GPC
ALPHA2 25-40 N	180	G 1 1/2	97993165	98091787	19	
ALPHA2 25-40 N	180	G 1 1/2	98890867	98091787	19	
ALPHA2 25-60	130	G 1 1/2	97993156	98091786	22	
ALPHA3 25-60	130	G 1 1/2	98890795	98091786	22	
ALPHA2 25-60 N	130	G 1 1/2	97993164	98091786	22	
ALPHA3 25-60 N	130	G 1 1/2	98890864	98091786	22	
ALPHA2 25-60	180	G 1 1/2	97993159	98091787	22	
ALPHA3 25-60	180	G 1 1/2	98890801	98091787	22	
ALPHA2 25-60 A	180	G 1 1/2	97993160	505822	23	
ALPHA3 25-60 A	180	G 1 1/2	98890803	505822	23	
ALPHA2 25-60 N	180	G 1 1/2	97993166	98091787	22	
ALPHA3 25-60 N	180	G 1 1/2	98890867	98091787	22	
ALPHA2 25-80	130	G 1 1/2	98649756	98091786	24	
ALPHA3 25-80	130	G 1 1/2	98890796	98091786	24	
ALPHA2 25-80 N	130	G 1 1/2	98676788	98091786	24	

Pump type	Port-to-port length [mm]	Connection	Product number (incl. insulating shells)	Insulating kit (separate)	Data sheet Page	QR code for GPC
ALPHA3 25-80 N	130	G 1 1/2	98890865	98091786	24	
ALPHA2 25-80	180	G 1 1/2	98649760	98091787	24	
ALPHA3 25-80	180	G 1 1/2	98890802	98091787	24	
ALPHA2 25-80 N	180	G 1 1/2	98676789	98091787	24	
ALPHA3 25-80 N	180	G 1 1/2	98890869	98091787	24	
ALPHA2 32-40	180	G 2	97993161	98091787	25	
ALPHA3 32-40	180	G 2	98890804	98091787	25	
ALPHA2 32-40 N	180	G 2	97993167	98091787	25	
ALPHA3 32-40 N	180	G 2	98890870	98091787	25	
ALPHA2 32-60	180	G 2	97993162	9809178	27	
ALPHA3 32-60	180	G 2	98890807	9809178	27	
ALPHA2 32-60 N	180	G 2	97993168	98091787	27	
ALPHA3 32-60 N	180	G 2	98890871	98091787	27	
ALPHA2 32-80	180	G 2	98676781	98091787	28	
ALPHA3 32-80	180	G 2	98890808	98091787	28	

Pump type	Port-to-port length [mm]	Connection	Product number (incl. insulating shells)	Insulating kit (separate)	Data sheet Page	QR code for GPC
ALPHA2 32-80 N	180	G 2	98676790	98091787	28	
ALPHA3 32-80 N	180	G 2	98890872	98091787	28	

8. Grundfos Product Center

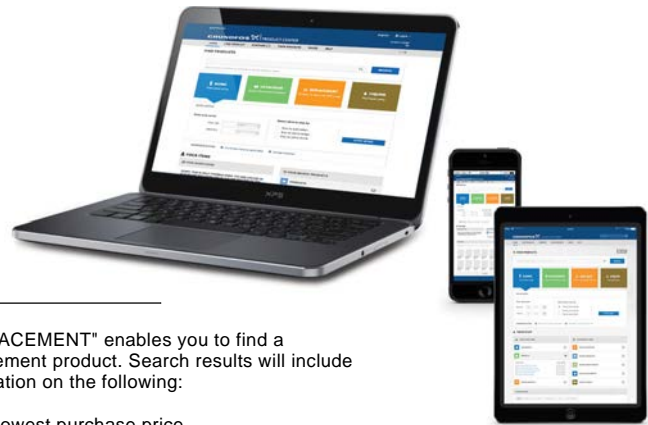

"SIZING" enables you to size a pump based on entered data and selection choices.

"REPLACEMENT" enables you to find a replacement product. Search results will include information on the following:

- the lowest purchase price
- the lowest energy consumption
- the lowest total life cycle cost.

www.grundfos.com Login

GRUNDFOS | PRODUCT CENTER Product range: United Kingdom | 50 Hz | Language: English
Change settings

HOME FIND PRODUCT COMPARE YOUR PROJECTS SAVED ITEMS HELP 1.4.23

FIND PRODUCTS AND SOLUTIONS

Input product number or a whole or partial product name

SIZING Enter pump sizing

CATALOGUE Products and services

REPLACEMENT Replace an old pump with a new

LIQUIDS Find pump by liquid

QUICK SIZING

Enter duty point:

Flow (Q)* m³/h

Head (H)* m

Select what to size by:

Size by application

Size by pump design

Size by pump family

START SIZING

ADVANCED SIZING: Advanced sizing by application Guided selection

"CATALOGUE" gives you access to the Grundfos product catalogue.

"LIQUIDS" enables you to find pumps designed for aggressive, flammable or other special liquids.

All the information you need in one place

Performance curves, technical specifications, pictures, dimensional drawings, motor curves, wiring diagrams, spare parts, service kits, 3D drawings, documents, system parts. The Product Center displays any recent and saved items - including complete projects - right on the main page.

Downloads

On the product pages, you can download installation and operating instructions, data booklets, service instructions, etc. in PDF format.

Subject to alterations.

98144996 0615

ECM: 1162070

GRUNDFOS A/S
DK-8850 Bjerringbro . Denmark
Telephone: +45 87 50 14 00

GRUNDFOS 