

ServeLine  
Design handbook

**Hoval**

Responsibility for energy and environment



Energy-efficient air conditioning for data centres





### ServeCool SW

Air-conditioning unit for indirect free cooling with fresh air in combination with adiabatic and mechanical cooling

3



### ServeCool SWP

Air-conditioning unit for indirect free cooling with fresh air in combination with adiabatic and mechanical cooling, with integrated adiabatic pump

15



### Options

27



### Transport and installation

31

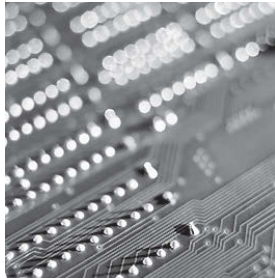

### Control systems

37



### System design

41

A

B

C

D

E

F





## ServeCool SW

Air-conditioning unit for indirect free cooling with fresh air in combination with adiabatic and mechanical cooling

1 Use	4
2 Construction and operation	4
3 Technical data	8
4 Specification texts	11

## 1 Use

### 1.1 Intended use

ServeCool SW is an air-conditioning unit for cooling data centres. It cools the IT environment indirectly with high-efficiency plate heat exchangers. This means the air in the server room is completely separated from the fresh air outside, which eliminates the possibility of dust or variations in fresh air humidity affecting highly sensitive IT equipment. The system uses the interaction of different resources for cooling with minimal energy consumption depending on the current environmental conditions:

- Indirect free cooling with fresh air
- Indirect adiabatic cooling
- Mechanical cooling via cooling coil

The ServeCool SW is suitable for use in data centres with one hundred to several thousand square metres of air-conditioned IT area. The system's cooling power can be scaled up as required simply by connecting several units in series.

In order to maintain defined air humidity values in the server room, the ServeCool SW can activate an external humidifier (option).

Also included under intended use are compliance with the installation, commissioning, operating and maintenance provisions (operating instructions). Any usage over and above this use is considered to be not as intended. The manufacturer shall not be held responsible for any damage resulting from such use.

### 1.2 User group

The unit may only be installed, operated and serviced by authorised and trained specialist personnel who are familiar with the unit and aware of the risks involved. The operating instructions are for English-speaking operating engineers and technicians as well as specialists in building, heating and air technology.

## 2 Construction and operation

The ServeCool SW has been specially designed for energy-efficient cooling of data centres. It fulfils the following functions:

- Cooling in recirculation operation (with connection to on site fully demineralised water treatment and on site chilled water system)
- Filtering of the extract air
- Actuation of a humidifier (optional)

The unit cools in recirculation operation, which means it draws in extract air from the server room, cools it and blows it back into the room as supply air. Depending on the current temperature and humidity conditions, various cooling processes will be taking place simultaneously.

#### Indirect free cooling with fresh air

The unit draws in cool fresh air. This flows through the two plate heat exchangers, thereby cooling the supply air flow, and is then blown back outside.

#### Indirect adiabatic cooling

The evaporative cooling (adiabatic system) is operating: fully demineralised water is sprayed into the fresh air flow. Evaporation of the water cools the air; the additional cooling capacity is transferred to the supply air via the plate heat exchanger.

On site central fully demineralised water treatment with a redundant pumping station supplies the adiabatic system with fully demineralised water. The pressure of the supply water is used directly at the spray nozzles for spraying the heat exchanger with water.

#### Mechanical cooling

The supply air is mechanically cooled by a cooling coil.



2.1 Construction

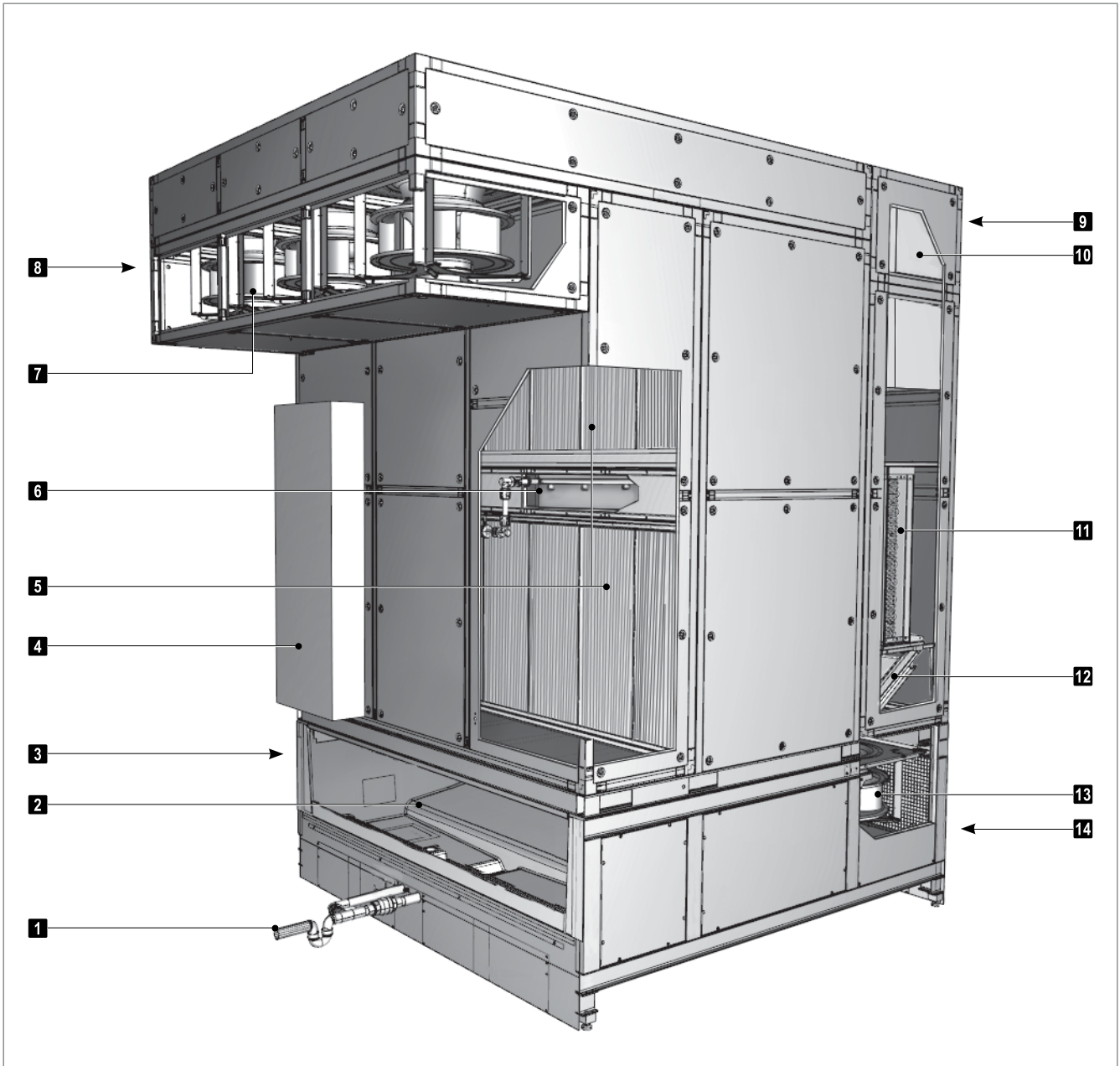

- |  |  |
|--|--|
| <ul style="list-style-type: none"> <li><b>1</b> Discharge</li> <li><b>2</b> Trough</li> <li><b>3</b> Duct connection fresh air</li> <li><b>4</b> Control box</li> <li><b>5</b> Plate heat exchangers</li> <li><b>6</b> Spray nozzles</li> <li><b>7</b> Exhaust air fans</li> </ul> | <ul style="list-style-type: none"> <li><b>8</b> Duct connection exhaust air</li> <li><b>9</b> Duct connection extract air</li> <li><b>10</b> Extract air filter</li> <li><b>11</b> Cooling coil</li> <li><b>12</b> Bypass damper</li> <li><b>13</b> Supply air fans</li> <li><b>14</b> Duct connection supply air</li> </ul> |
|--|--|

Fig. A1: Components of the ServeCool SW

## 2.2 Function diagram

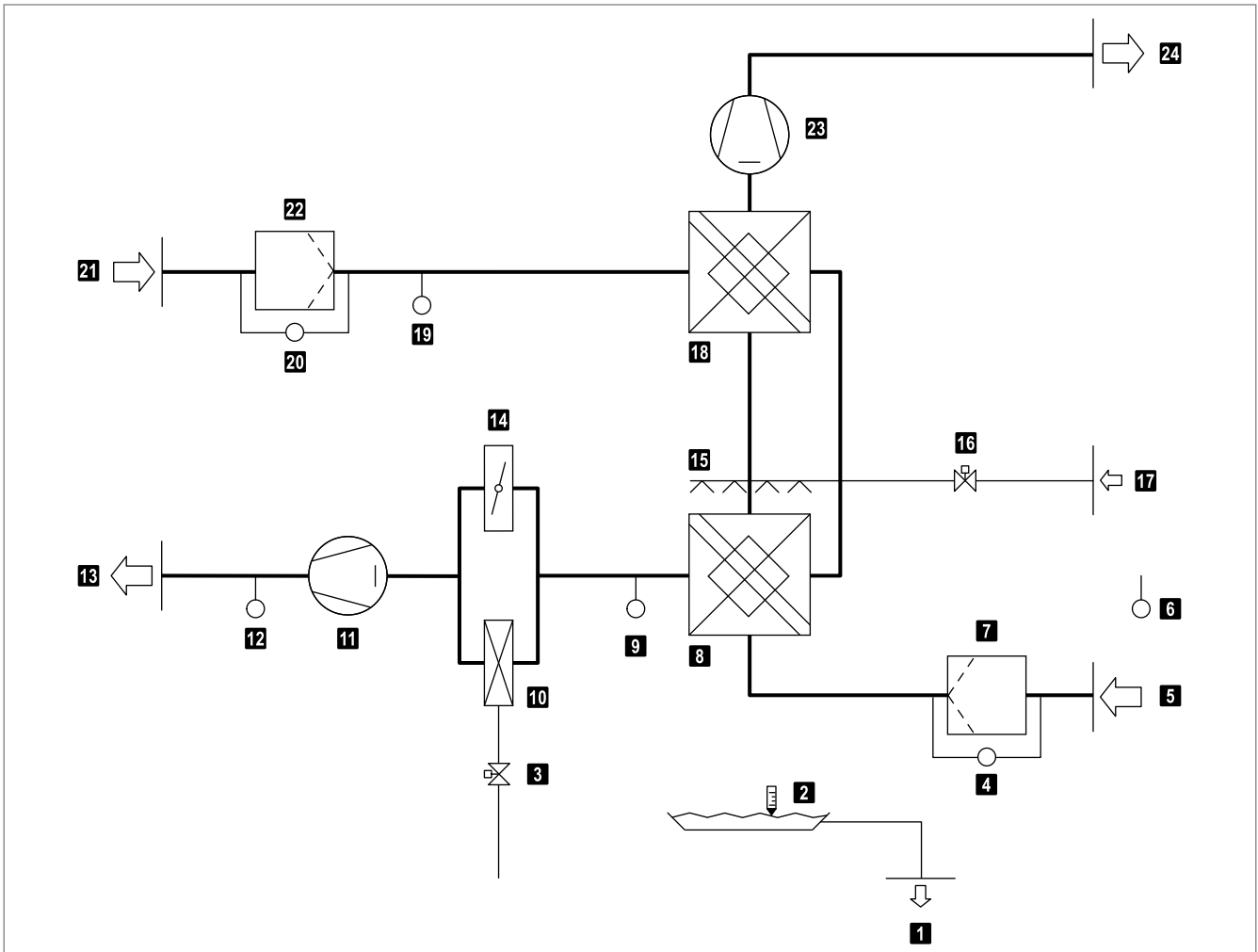

<b>1</b> Discharge	<b>13</b> Supply air
<b>2</b> Trough with liquid level switch	<b>14</b> Bypass damper with actuator
<b>3</b> Cooling valve (option)	<b>15</b> Spray nozzles
<b>4</b> Filter monitoring fresh air	<b>16</b> Feed valve
<b>5</b> Fresh air	<b>17</b> Water supply
<b>6</b> Fresh air combination sensor (temperature, humidity)	<b>18</b> Plate heat exchanger 2
<b>7</b> Fresh air filter (option)	<b>19</b> Extract air combination sensor (temperature, humidity)
<b>8</b> Plate heat exchanger 1	<b>20</b> Filter monitoring extract air
<b>9</b> Energy monitoring combination sensor (temperature, humidity)	<b>21</b> Extract air
<b>10</b> Cooling coil	<b>22</b> Extract air filter
<b>11</b> Supply air fan	<b>23</b> Exhaust air fan
<b>12</b> Supply air combination sensor (temperature, humidity)	<b>24</b> Exhaust air

Fig. A2: Function diagram



## 2.3 Operating modes

The ServeNet control system controls the unit according to demand and depending on the operating conditions. The integrated ServeUnit controller or higher-level building management system allow the following operating modes to be specified:

Operating mode	Description	Use
<b>Summer operation</b>	<p>The unit uses the following cooling processes depending on the temperature and moisture conditions:</p> <ul style="list-style-type: none"> <li>■ Indirect free cooling with fresh air</li> <li>■ Indirect adiabatic cooling</li> <li>■ Mechanical cooling</li> </ul> <p>The chiller for supplying the cooling coil and the fully demineralised water treatment are in operation.</p>	During the hot season
<b>Winter operation</b>	<p>The unit uses the following cooling processes depending on the temperature and moisture conditions:</p> <ul style="list-style-type: none"> <li>■ Indirect free cooling with fresh air</li> <li>■ Mechanical cooling</li> </ul> <p>The chiller for supplying the cooling coil is in operation. There is no need for a fully demineralised water supply.</p>	During the cold season and in transitional periods

### 3 Technical data

#### 3.1 Unit type reference

SW - 25 / KS ...	
<b>Unit type</b>	ServeCool SW
<b>Unit size</b>	25
<b>Cooling coil</b>	Standard
<b>Further options</b>	See section C 'Options' in this handbook

Table A1: Unit type reference

#### 3.2 Application limits

Fresh air temperature	min.	-30	°C
	max.	45	°C
Extract air temperature	max.	45	°C
Supply air temperature	min.	15	°C

Table A2: Application limits in operation

#### 3.3 Air flow rate, electrical connection

Unit type				SWP-25
Nominal air flow rate	Supply air	max.	25750	m <sup>3</sup> /h
	Fresh air	max.	22000	m <sup>3</sup> /h
Electrical connection	Supply voltage		3 x 400	V AC
	Permitted voltage tolerance		± 10	%
	Frequency		50	Hz
	Current consumption	max.	32.4	A
	Power consumption	max.	20.4	kW
Extract air filter	Filter class		G4	
	Filter monitoring factory setting		200	Pa
Fresh air filter (option)	Filter class		M5	
	Filter monitoring factory setting		350	Pa

Table A3: Air flow rate, electrical connection

### 3.4 Sound level

Unit type		SW-25	
Sound pressure level (at a distance of 5 m) <sup>1)</sup>		dB(A)	60
Total sound power level <sup>2)</sup>		dB(A)	82
Octave sound power level	63 Hz	dB(A)	52.4
	125 Hz	dB(A)	72.8
	250 Hz	dB(A)	72.5
	500 Hz	dB(A)	70.6
	1000 Hz	dB(A)	70.5
	2000 Hz	dB(A)	66.2
	4000 Hz	dB(A)	58.6
	8000 Hz	dB(A)	48.2

<sup>1)</sup> with hemispherical radiation in a low-reflection environment (enveloping surface process)

<sup>2)</sup> determined by intensity process

Table A4: Sound level (fresh air, discharge side)



**Note**

To reduce the noise level at night, the speed of the exhaust air fans can be limited to an adjustable set value using the control system.

### 3.5 Cooling capacity

Cooling capacity		
Total		120 kW
Free and adiabatic cooling		108 kW
Mechanical		12 kW
Operating point		
Extract air conditions	38 °C / 18 % r.h.	
Supply air conditions	24 °C / 40 % r.h.	
Fresh air conditions	35 °C / 22 % r.h.	
Cooling coil data		
Supply/return temperature	14/20 °C	
Water quantity	1873 l/h	
Water pressure drop	0.44 kPa	

Table A5: Cooling capacity



**Note**

The cooling capacity varies depending on the ambient conditions. For data tables of further operating points, refer to section F 'System design'.

### 3.6 Dimensions and weights

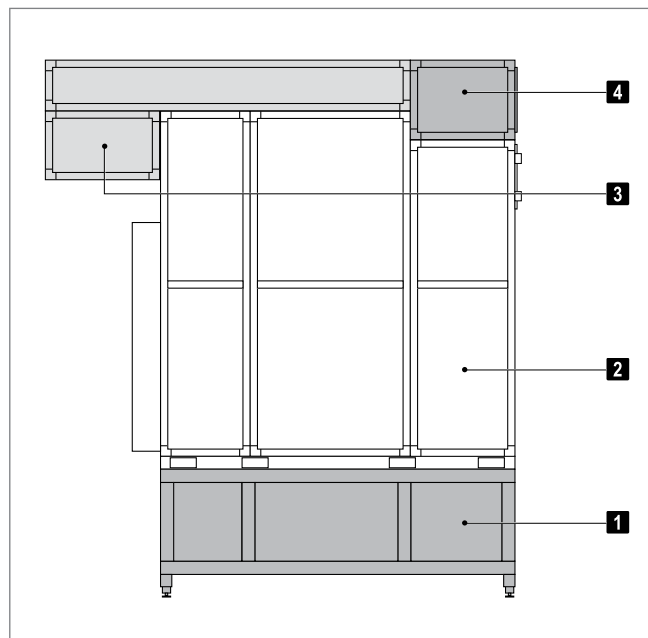

- 1** Base frame
- 2** Tower
- 3** Exhaust air box
- 4** Extract air box

Fig. A3: Components of the ServeCool SW

Weights		SW-25	
<b>Components</b>	Base frame	980	kg
	Tower	2000	kg
	Exhaust air box	580	kg
	Extract air box	100	kg
Water capacity	Cooling coil	40	kg
	Trough	250	kg
<b>Total</b>		<b>3950</b>	<b>kg</b>

Table A6: Weights of the ServeCool SW

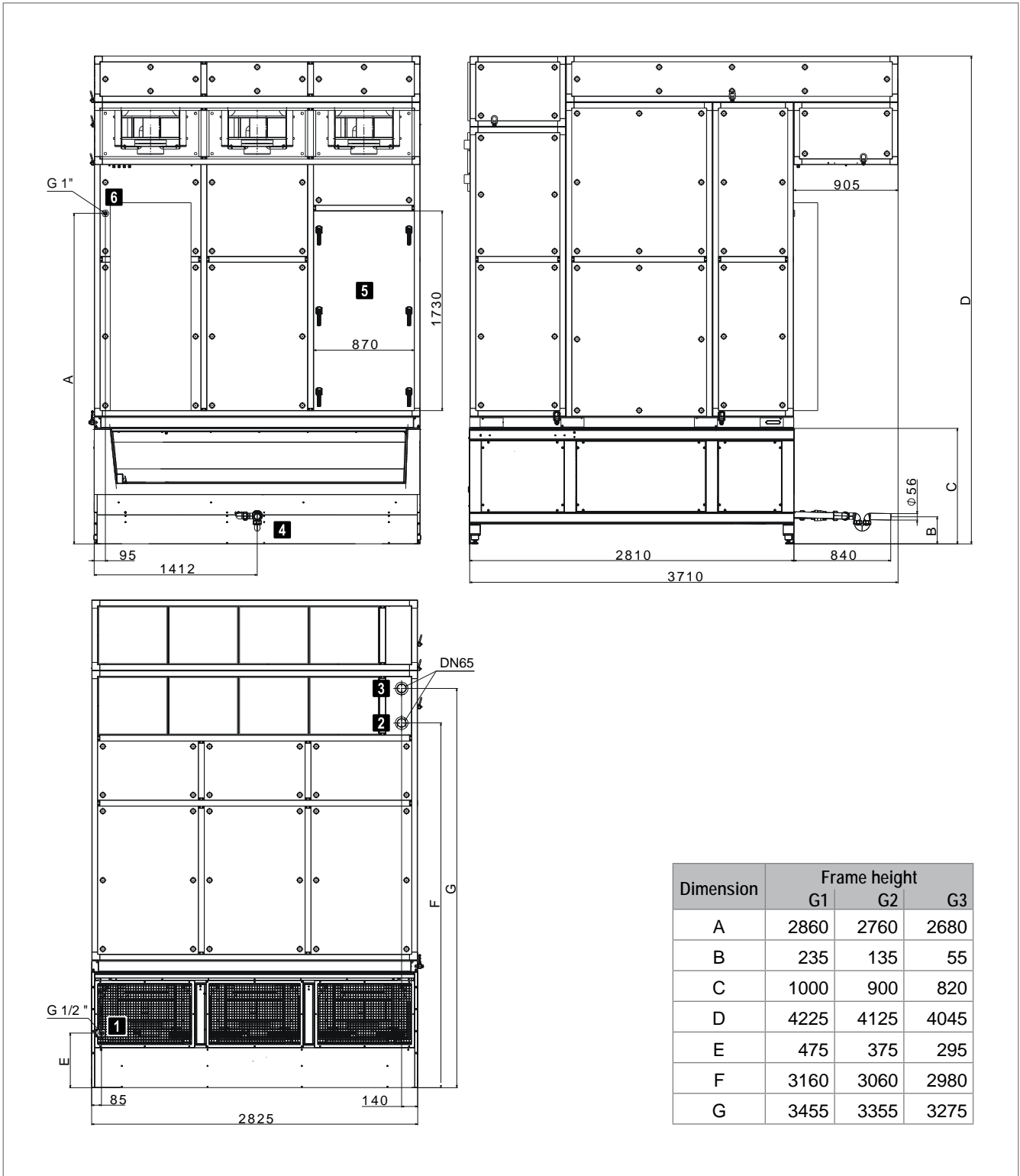

**1** Condensate connection

**2** Cooling coil return

**3** Cooling coil flow

**4** Discharge

**5** Tower access door

**6** Water supply

Fig. A4: Dimensional drawing (dimensions in mm)

## 4 Specification texts

### ServeCool SW

Innovative air-conditioning unit for recirculation cooling in data centres subject to a high temperature load. The unit uses various cooling processes: indirect free cooling with fresh air via high-performance plate heat exchanger is supplemented by indirect adiabatic cooling as well as mechanical cooling.

The ServeCool SW consists of the following components:

- Base frame
- Tower
- Extract air box
- Exhaust air box
- Control system
- Optional components

---

#### Base frame

---

Support frame construction of galvanized steel sections, welded and bolted; fitted with eyelets for crane transport and installation on site.

The base frame contains:

##### Supply air fans:

Designed as maintenance-free, direct-drive radial fans with high-efficiency EC motors, backwards-curved, 3D contoured blades and a free-running rotating wheel made of a high-performance composite material; infinitely variable (3 pieces).

##### Trough:

Fibre-glass-reinforced, insulated plastic trough with liquid level switch for monitoring the level, including integrated drain and emergency overflow.

##### Legs:

Adjustable legs for levelling and aligning the device on uneven surfaces.

---

#### Tower

---

Support frame construction of stainless-steel sections, welded.

Panel construction set up in supporting frame of aluminium sections, connected together and bolted; with insulation made of water-expanded polyurethane. The casing complies with air leakage class L3 acc. to EN 1886 and fire protection class B-s3, d0 acc. to EN 13501-1:2002.

The tower contains:

##### 2 cross-flow plate heat exchangers:

In waterproof design for indirect free cooling of the supply air for data centres. Exchanger package consists of epoxy-coated aluminium plates with pressed-in spacers. The plates are connected by a double fold, which gives several times the material thickness at the air entry and exit. The corners of the exchanger package are cast into the extruded aluminium hollow sections of the casing with a sealing compound to form a water-tight seal. The stainless steel side walls have a high-quality paint coating and are bolted flush with the above and sealed to make them water-tight. Thus the exchangers are resistant to pressures up to 2500 Pa.

Accumulating condensate is collected in a stainless-steel channel and drained outside by a hose trap. The cross-flow plate heat exchangers are Eurovent-certified and achieve efficiency class H1 to EN 13053.

##### Adiabatic system:

Spray humidifier comprising pipes and tangential full cone nozzles, made of a fully demineralised water-resistant plastic, mounted in a stainless-steel frame; activated by a solenoid valve with actuator and limit switches; pressure-resistant up to 16 bar (corresponding to DIN EN 12201-2). The connection system is certified according to DVGW guidelines.

##### Cooling coil:

Comprising copper pipes and aluminium fins with collecting channel for condensate drain made from stainless steel; hose trap with connection to trap of plate heat exchanger. The condensation drain is supplied by the client.

##### Bypass damper:

Lamellar damper for directing the supply air flow through the cooling coil or the bypass; including actuator with OPEN/CLOSED feedback. The damper fulfils leakage class 2 according to DIN EN 1751. Channelling the air through the bypass minimises the air-side pressure drop when no mechanical cooling is required.

##### Access openings:

- Tower access door: large access opening for easy access to the cross-flow plate heat exchangers for maintenance and to the components of the adiabatic system.
- Supply air access door: large access opening for easy access to the cooling coil, the bypass damper and the supply air fans for maintenance.

---

**Control box with ServeUnit controller as part of the Hoval ServeNet control system:**

- Control box made of sheet steel, powder-coated with textured paint in Hoval red (RAL 3000).
- ServeUnit controller fully prewired with the following peripheral components:
  - Feed valve
  - Bypass damper actuator
  - Extract air combination sensor (temperature, humidity)
  - Energy monitoring combination sensor (temperature, humidity)
  - Filter monitoring extract air
- Control module prewired ready-to-connect with the following peripheral components:
  - Supply air fans
  - Exhaust air fans
  - Liquid level switch
  - Supply air combination sensor (temperature, humidity)
  - Fresh air combination sensor (temperature, humidity)
  - Filter monitoring fresh air
  - Cooling valve
- Fresh air combination sensor (supplied)
- Mains power terminals
- Cable glands designed as cable feedthrough plates

---

**Extract air box**

---

Support frame construction of aluminium sections, attached and bolted, insulated panel construction; fitted with eyelets for crane transport and assembly on site.

The extract air box contains:

**Extract air filter:**

Designed as a G4 class bag filter, including differential pressure switches for filter monitoring.

---

**Exhaust air box**

---

Support frame construction of aluminium sections, attached and bolted, insulated panel construction; fitted with eyelets for crane transport and assembly on site.

The exhaust air box contains:

**Exhaust air fans:**

Designed as maintenance-free, direct-drive radial fans with high-efficiency EC motors, backwards-curved, 3D contoured blades and a free-running rotating wheel made of a high-performance composite material; infinitely variable (3 pieces).

---

**Options for the unit**

---

**Extract air filter AM:**

Class M5 extract air filter as compact filter instead of G4 for optimised filtering of the recirculated air.

**Frame height:**

Modified height of the base frame for adapting to the structure of the false floor (820 mm or 900 mm).

**Cooling valve:**

Non-pressure dependent compensating and control valve as automatic combination valve for control and hydraulic balancing, comprising linear control valve, pressure controller with integrated diaphragm and actuator.

**Fresh air box:**

For directly connecting the fresh air intake to the ServeCool unit by means of an insulated air duct produced in a panel design; equipped with legs for adapting to the frame height. The fresh air box contains the fresh air filter, configured as a class M5 compact filter and the fresh air damper for closing the fresh air opening during maintenance work.

---

### ServeNet control system

---

Control system for the energy-optimised operation of Hoval ServeCool, designed as a decentralised system, with the following main features:

- ServeUnit controller integrated in every unit, for autonomous and individual control of the unit, allowing for demand-controlled adaptation to the operating conditions. The components used are tried-and-tested in the industry and are characterised by their very high level of availability. In the event of a fault, it is possible to obtain a standard component quickly as a spare part.
- Simple wiring of the units to a building management system by an interface (Modbus IP) integrated into the ServeUnit controller
- Possibility of visualisation, set value specification, alarm management, group switching or maintenance management via BMS
- Manual switch for local operation in case of failure of the bus communication
- Seamless recording of all relevant parameters and alarm management
- Service access via separate service interface
- Visualisation and control directly on the unit by web browser via HTML interface
- Simple integration into the Datacenter Infrastructure Management (DCIM)
- The following control functions are performed by the ServeUnit controller:
  - Control of the supply air temperature with extract air temperature limiting and fixed setting of the supply air volume flow
  - Fire control: Connection for an external signal to shut the plant down in the event of a fire
- Units are fully prewired, tested and ready to be connected
- Electrical documentation supplied in the control box

### Actuation of humidifier type 1:

Electrical components and software interface for transmission of signals between the Hoval ServeCool and an external humidifier (e.g. 0...10 V or 0...20 mA); electrical components installed in the control box and fully prewired.

### Actuation of humidifier type 2:

Electrical components installed in the control box and fully prewired for actuation of an ultrasound humidifier with approx. 5 kg/h humidification performance.

### Protection module:

Surge voltage protection for protecting the unit against surge voltages from atmospheric discharges and switching operations.

---

### Options for the control system

---

#### Controller supply:

Uninterruptible power supply for the ServeUnit controller in case of intermittent electrical power supply outages or frequency fluctuations.

#### Source changeover:

For redundant power supply, it is possible to switch over between two alternative electrical power supply pathways. The switchover time between the two power supplies can be adjusted in seconds. The switchover only takes place if the phase sequence check and phase monitoring enable the switching.

The 'source switchover' option also includes the controller supply (i.e. uninterruptible power supply for the ServeUnit controller).



---

**Technical data**

---

- Nominal air flow rate supply air: \_\_\_\_\_ m<sup>3</sup>/h
- Nominal air flow rate fresh air: \_\_\_\_\_ m<sup>3</sup>/h
- Cooling capacity: \_\_\_\_\_ kW
  - at supply air temperature: \_\_\_\_\_ °C
  - at supply air humidity: \_\_\_\_\_ % r.h.
  - at fresh air temperature: \_\_\_\_\_ °C
  - at fresh air humidity: \_\_\_\_\_ % r.h.

**Dimensions**

- ServeCool (footprint x height): 2810 x 2825 x 4225 mm
- Maintenance area supply air side: 2825 x 1000 mm
- Maintenance area fresh air side: 2825 x 1200 mm

**Weight**

- ServeCool: 3950 kg

**Electrical connection**

- Supply voltage: 3 x 400 VAC / 50 Hz
- Current consumption: max. 32.4 A
- Power consumption: max. 20.4 kW

**Sound data**

- Sound pressure level at 5 m distance from unit: 60 dB(A)
- Total sound power level: 82 dB(A)

**Plate heat exchanger**

- Fresh air temperature at free cooling limit: \_\_\_\_\_ °C
- Fresh air relative humidity: \_\_\_\_\_ % r.h.
- Extract air temperature: \_\_\_\_\_ °C
- Extract air relative humidity: \_\_\_\_\_ % r.h.
- Heat recovery efficiency dry fresh air side/extract air side at nominal air flow rate: \_\_\_\_\_ / \_\_\_\_\_ %
- Pressure drop fresh air side/extract air side at nominal air flow rate: \_\_\_\_\_ / \_\_\_\_\_ Pa

**Technical data cooling coil**

- Cooling capacity, total: \_\_\_\_\_ kW
- Cooling capacity, sensitive: \_\_\_\_\_ kW
- Flow/return: \_\_\_\_\_ / \_\_\_\_\_ °C
- Supply air temperature: \_\_\_\_\_ °C
  - for inlet temperature: \_\_\_\_\_ °C
  - with rel. inlet humidity: \_\_\_\_\_ % r.h.
- Operating pressure: \_\_\_\_\_ kPa



---

## ServeCool SWP

Air-conditioning unit for indirect free cooling with fresh air in combination with adiabatic and mechanical cooling, with integrated adiabatic pump

---

B

1 Use	16
2 Construction and operation	16
3 Technical data	20
4 Specification texts	23

## 1 Use

### 1.1 Intended use

ServeCool SWP is an air-conditioning unit for cooling data centres. It cools the IT environment indirectly with high-efficiency plate heat exchangers. This means the air in the server room is completely separated from the fresh air outside, which eliminates the possibility of dust or variations in fresh air humidity affecting highly sensitive IT equipment. The system uses the interaction of different resources for cooling with minimal energy consumption depending on the current environmental conditions:

- Indirect free cooling with fresh air
- Indirect adiabatic cooling
- Mechanical cooling via cooling coil

The ServeCool SWP is suitable for use in data centres with one hundred to several thousand square metres of air-conditioned IT area. The system's cooling power can be scaled up as required simply by connecting several units in series.

In order to maintain defined air humidity values in the server room, the ServeCool SWP can activate an external humidifier (option).

Also included under intended use are compliance with the installation, commissioning, operating and maintenance provisions (operating instructions). Any usage over and above this use is considered to be not as intended. The manufacturer shall not be held responsible for any damage resulting from such use.

### 1.2 User group

The unit may only be installed, operated and serviced by authorised and trained specialist personnel who are familiar with the unit and aware of the risks involved. The operating instructions are for English-speaking operating engineers and technicians as well as specialists in building, heating and air technology.

## 2 Construction and operation

The ServeCool SWP has been specially designed for energy-efficient cooling of data centres. It fulfils the following functions:

- Cooling in recirculation operation (with connection to on site fully demineralised water treatment and on site chilled water system)
- Filtering of the extract air
- Actuation of a humidifier (optional)

The unit cools in recirculation operation, which means it draws in extract air from the server room, cools it and blows it back into the room as supply air. Depending on the current temperature and humidity conditions, various cooling processes will be taking place simultaneously.

#### Indirect free cooling with fresh air

The unit draws in cool fresh air. This flows through the two plate heat exchangers, thereby cooling the supply air flow, and is then blown back outside.

#### Indirect adiabatic cooling

The evaporative cooling (adiabatic system) is operating: fully demineralised water is sprayed into the fresh air flow. Evaporation of the water cools the air; the additional cooling capacity is transferred to the supply air via the plate heat exchanger.

A circulating water pump integrated in the unit supplies the adiabatic system with fully demineralised water. This means the spray nozzles are independent from the supply pressure of the fully demineralised water treatment in the building. The water supply and discharge pipe on site can be configured with a smaller size than for the ServeCool SW, because the waste water removal of the trough can be enabled by the control for each individual unit.

#### Mechanical cooling

The supply air is mechanically cooled by a cooling coil.

2.1 Construction

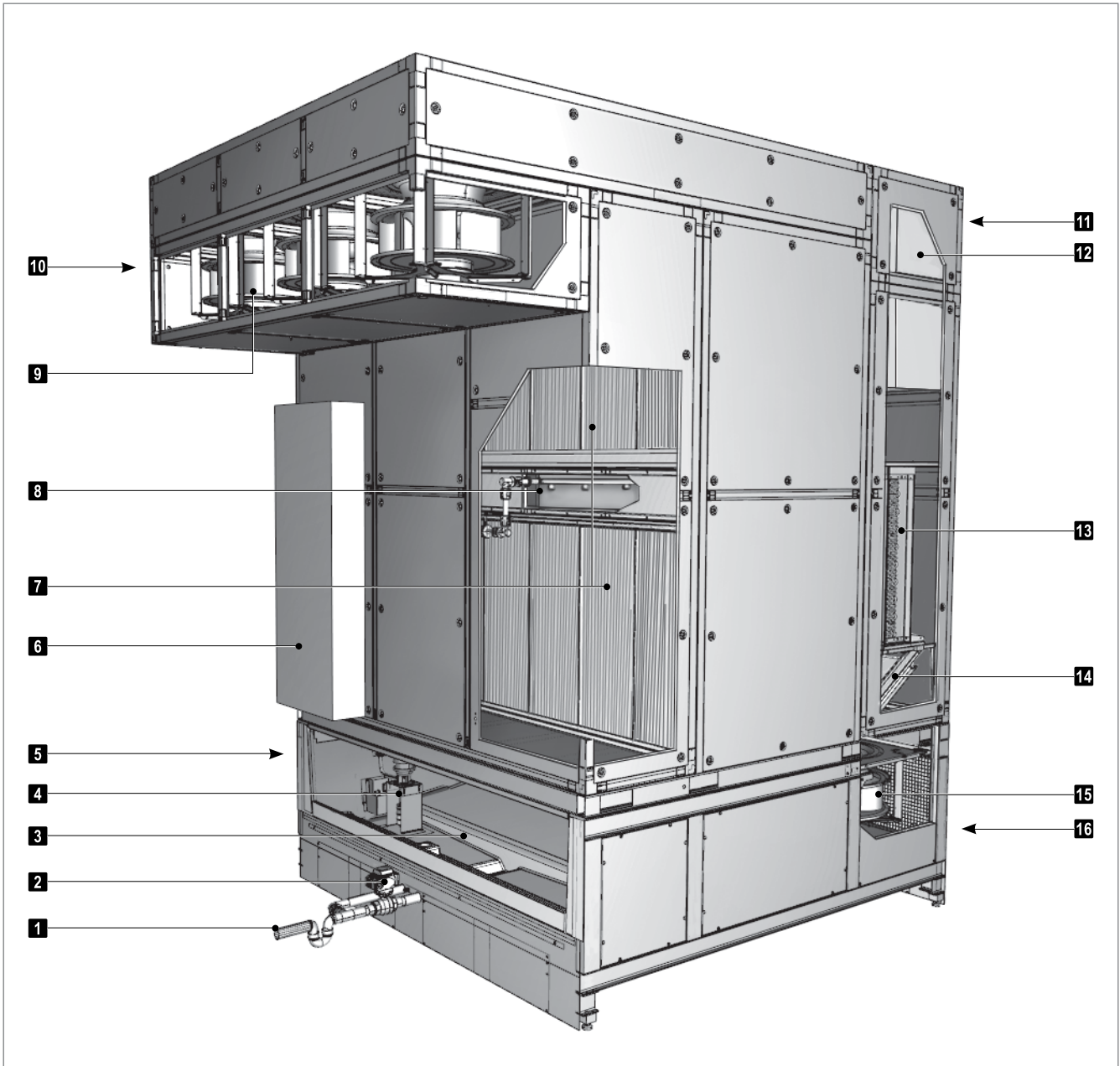

- |                                    |                                       |
|------------------------------------|---------------------------------------|
| <b>1</b> Discharge                 | <b>9</b> Exhaust air fans             |
| <b>2</b> Drain valve               | <b>10</b> Duct connection exhaust air |
| <b>3</b> Trough                    | <b>11</b> Duct connection extract air |
| <b>4</b> Adiabatic pump            | <b>12</b> Extract air filter          |
| <b>5</b> Duct connection fresh air | <b>13</b> Cooling coil                |
| <b>6</b> Control box               | <b>14</b> Bypass damper               |
| <b>7</b> Plate heat exchangers     | <b>15</b> Supply air fans             |
| <b>8</b> Spray nozzles             | <b>16</b> Duct connection supply air  |

Fig. B1: Components of the ServeCool SWP

## 2.2 Function diagram

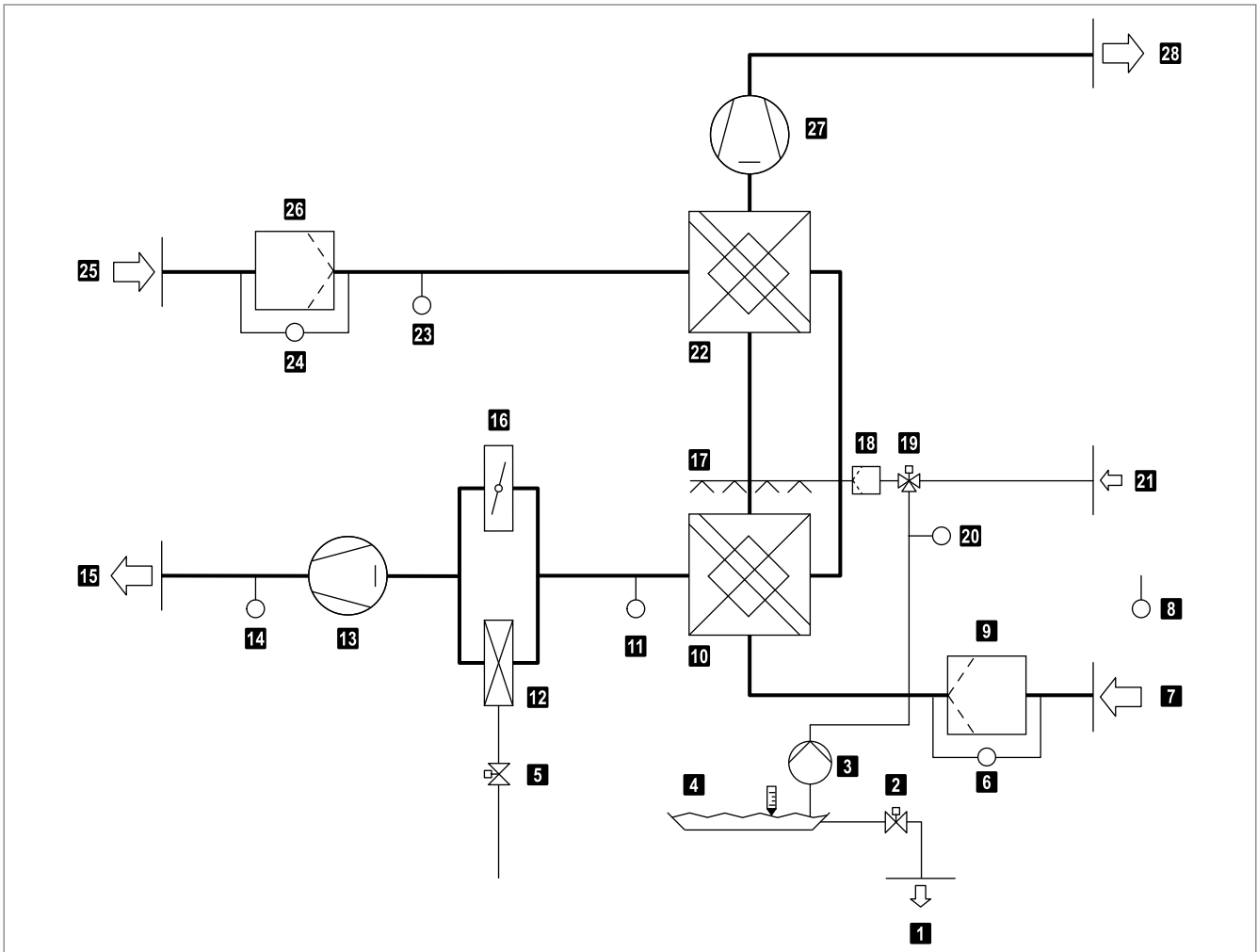

<b>1</b> Discharge	<b>15</b> Supply air
<b>2</b> Drain valve	<b>16</b> Bypass damper with actuator
<b>3</b> Adiabatic pump	<b>17</b> Spray nozzles
<b>4</b> Trough with liquid level switch	<b>18</b> Water filter
<b>5</b> Cooling valve (option)	<b>19</b> Feed valve
<b>6</b> Filter monitoring fresh air	<b>20</b> Conductance measurement
<b>7</b> Fresh air	<b>21</b> Water supply
<b>8</b> Fresh air combination sensor (temperature, humidity)	<b>22</b> Plate heat exchanger 2
<b>9</b> Fresh air filter (option)	<b>23</b> Extract air combination sensor (temperature, humidity)
<b>10</b> Plate heat exchanger 1	<b>24</b> Filter monitoring extract air
<b>11</b> Energy monitoring combination sensor (temperature, humidity)	<b>25</b> Extract air
<b>12</b> Cooling coil	<b>26</b> Extract air filter
<b>13</b> Supply air fan	<b>27</b> Exhaust air fan
<b>14</b> Supply air combination sensor (temperature, humidity)	<b>28</b> Exhaust air

Fig. B2: Function diagram

## 2.3 Operating modes

The ServeNet control system controls the unit according to demand and depending on the operating conditions. The integrated ServeUnit controller or higher-level building management system allow the following operating modes to be specified:

Operating mode	Description	Use
<b>Summer operation</b>	<p>The unit uses the following cooling processes depending on the temperature and moisture conditions:</p> <ul style="list-style-type: none"> <li>■ Indirect free cooling with fresh air</li> <li>■ Indirect adiabatic cooling</li> <li>■ Mechanical cooling</li> </ul> <p>The chiller for supplying the cooling coil and the fully demineralised water treatment are in operation.</p>	During the hot season
<b>Winter operation</b>	<p>The unit uses the following cooling processes depending on the temperature and moisture conditions:</p> <ul style="list-style-type: none"> <li>■ Indirect free cooling with fresh air</li> <li>■ Mechanical cooling</li> </ul> <p>The chiller for supplying the cooling coil is in operation. There is no need for a fully demineralised water supply.</p>	During the cold season and in transitional periods

### 3 Technical data

#### 3.1 Unit type reference

SWP - 25 / KS ...	
<b>Unit type</b>	ServeCool SWP
<b>Unit size</b>	25
<b>Cooling coil</b>	Standard
<b>Further options</b>	See section C 'Options' in this handbook

Table B1: Unit type reference

#### 3.2 Application limits

Fresh air temperature	min.	-30	°C
	max.	45	°C
Extract air temperature	max.	45	°C
Supply air temperature	min.	15	°C

Table B2: Application limits in operation

#### 3.3 Air flow rate, electrical connection

Unit type		SWP-25		
Nominal air flow rate	Supply air	max.	25750	m <sup>3</sup> /h
	Fresh air	max.	22000	m <sup>3</sup> /h
Electrical connection	Supply voltage		3 x 400	V AC
	Permitted voltage tolerance		± 10	%
	Frequency		50	Hz
	Current consumption	max.	34.4	A
	Power consumption	max.	21.2	kW
Extract air filter	Filter class		G4	
	Filter monitoring factory setting		200	Pa
Fresh air filter (option)	Filter class		M5	
	Filter monitoring factory setting		350	Pa

Table B3: Air flow rate, electrical connection



### 3.4 Sound level

Unit type		SWP-25	
Sound pressure level (at a distance of 5 m) <sup>1)</sup>		dB(A)	60
Total sound power level <sup>2)</sup>		dB(A)	82
Octave sound power level	63 Hz	dB(A)	52.4
	125 Hz	dB(A)	72.8
	250 Hz	dB(A)	72.5
	500 Hz	dB(A)	70.6
	1000 Hz	dB(A)	70.5
	2000 Hz	dB(A)	66.2
	4000 Hz	dB(A)	58.6
	8000 Hz	dB(A)	48.2

<sup>1)</sup> with hemispherical radiation in a low-reflection environment (enveloping surface process)

<sup>2)</sup> determined by intensity process

Table B4: Sound level (fresh air, discharge side)



**Note**

To reduce the noise level at night, the speed of the exhaust air fans can be limited to an adjustable set value using the control system.

### 3.5 Cooling capacity

Cooling capacity	
Total	120 kW
Free and adiabatic cooling	108 kW
Mechanical	12 kW
Operating point	
Extract air conditions	38 °C / 18 % r.h.
Supply air conditions	24 °C / 40 % r.h.
Fresh air conditions	35 °C / 22 % r.h.
Cooling coil data	
Supply/return temperature	14/20 °C
Water quantity	1873 l/h
Water pressure drop	0.44 kPa

Table B5: Cooling capacity



**Note**

The cooling capacity varies depending on the ambient conditions. For data tables of further operating points, refer to section F 'System design'.

### 3.6 Dimensions and weight

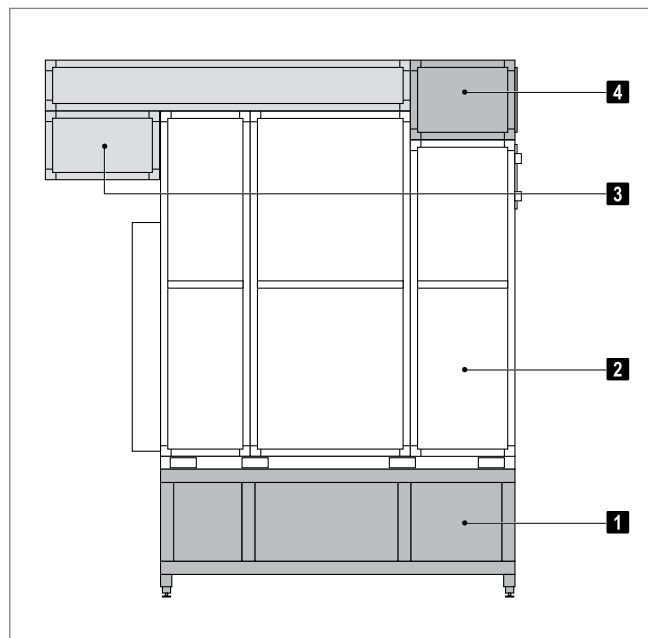

- 1** Base frame
- 2** Tower
- 3** Exhaust air box
- 4** Extract air box

Fig. B3: Components of the ServeCool SWP

Weights		SWP-25	
<b>Components</b>	Base frame	990	kg
	Tower	2005	kg
	Exhaust air box	580	kg
	Extract air box	100	kg
<b>Water capacity</b>	Cooling coil	40	kg
	Trough	250	kg
<b>Total</b>		<b>3965</b>	<b>kg</b>

Table B6: Weights of the ServeCool SWP

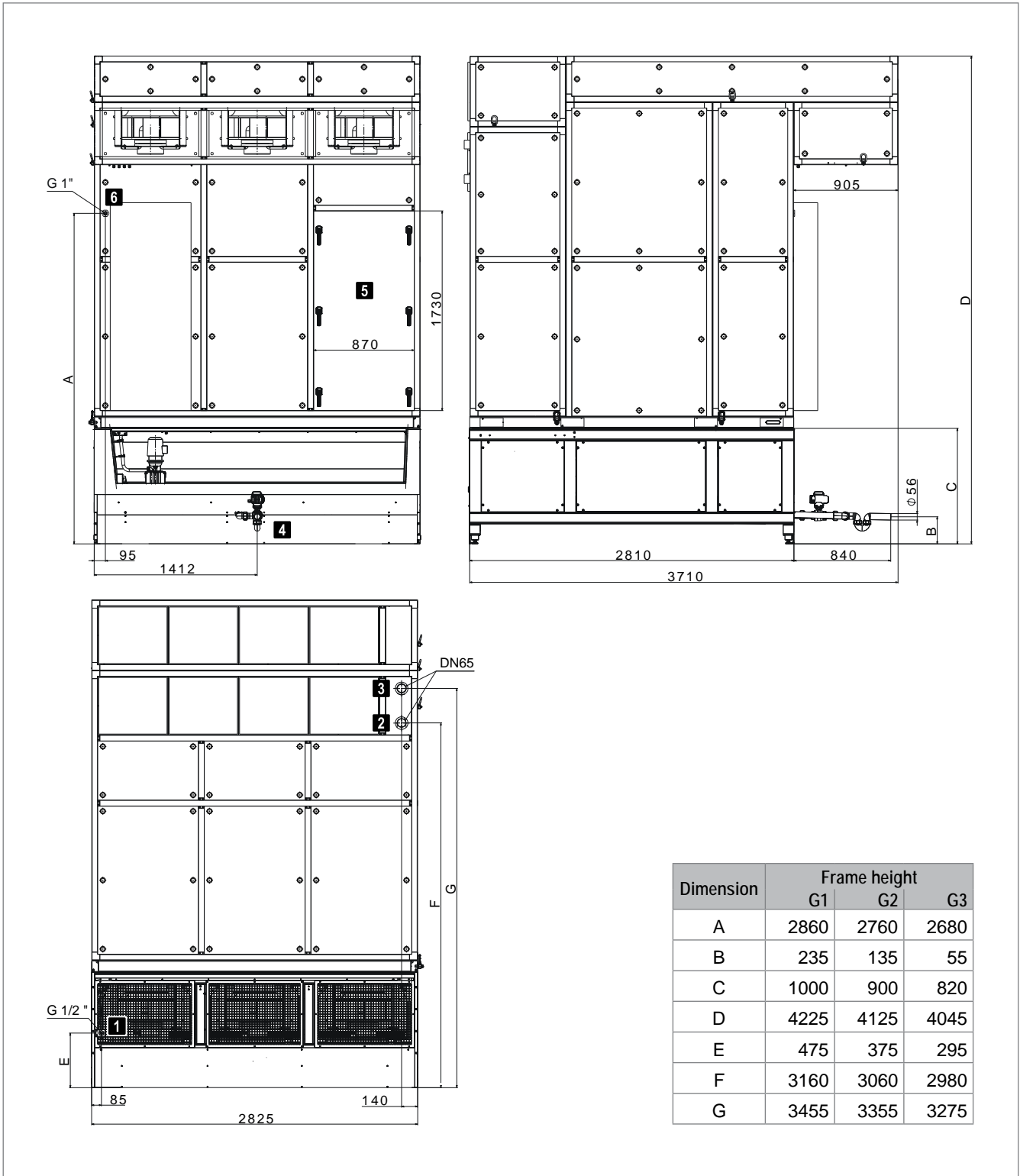

**1** Condensate connection

**2** Cooling coil return

**3** Cooling coil flow

**4** Discharge

**5** Tower access door

**6** Water supply

Fig. B4: Dimensional drawing (dimensions in mm)

## 4 Specification texts

### ServeCool SWP

Innovative air-conditioning unit for recirculation cooling in data centres subject to a high temperature load. The unit uses various cooling processes: indirect free cooling with fresh air via high-performance plate heat exchanger is supplemented by indirect adiabatic cooling as well as mechanical cooling.

The ServeCool SWP consists of the following components:

- Base frame
- Tower
- Extract air box
- Exhaust air box
- Control system
- Optional components

---

#### Base frame

---

Support frame construction of galvanized steel sections, welded and bolted; fitted with eyelets for crane transport and installation on site.

The base frame contains:

##### Supply air fans:

Designed as maintenance-free, direct-drive radial fans with high-efficiency EC motors, backwards-curved, 3D contoured blades and a free-running rotating wheel made of a high-performance composite material; infinitely variable (3 pieces).

##### Trough:

Fibre-glass-reinforced, insulated plastic trough with liquid level switch for monitoring the level, including integrated drain and emergency overflow.

##### Adiabatic pump:

Configured as high-performance centrifugal pump with fully demineralised water-resistant plastic housing and open impeller. Configuration with stainless steel shaft without seal, only mounted in the motor.

##### Legs:

Adjustable legs for levelling and aligning the device on uneven surfaces.

---

#### Tower

---

Support frame construction of stainless-steel sections, welded.

Panel construction set up in supporting frame of aluminium sections, connected together and bolted; with insulation made of water-expanded polyurethane. The casing complies with air leakage class L3 acc. to EN 1886 and fire protection class B-s3, d0 acc. to EN 13501-1:2002.

The tower contains:

##### 2 cross-flow plate heat exchangers:

In waterproof design for indirect free cooling of the supply air for data centres. Exchanger package consists of epoxy-coated aluminium plates with pressed-in spacers. The plates are connected by a double fold, which gives several times the material thickness at the air entry and exit. The corners of the exchanger package are cast into the extruded aluminium hollow sections of the casing with a sealing compound to form a water-tight seal. The stainless steel side walls have a high-quality paint coating and are bolted flush with the above and sealed to make them water-tight. Thus the exchangers are resistant to pressures up to 2500 Pa.

Accumulating condensate is collected in a stainless-steel channel and drained outside by a hose trap. The cross-flow plate heat exchangers are Eurovent-certified and achieve efficiency class H1 to EN 13053.

##### Adiabatic system:

Spray humidifier comprising pipes and tangential full cone nozzles, made of a fully demineralised water-resistant plastic, mounted in a stainless-steel frame; activated by a solenoid valve with actuator and limit switches; pressure-resistant up to 16 bar (corresponding to DIN EN 12201-2). The connection system is certified according to DVGW guidelines. A fine water filter is installed in the supply line to the tangential full cone nozzles.

##### Cooling coil:

Comprising copper pipes and aluminium fins with collecting channel for condensate drain made from stainless steel; hose trap with connection to trap of plate heat exchanger. The condensation drain is supplied by the client.

##### Bypass damper:

Lamellar damper for directing the supply air flow through the cooling coil or the bypass; including actuator with OPEN/CLOSED feedback. The damper fulfils leakage class 2 according to DIN EN 1751. Channelling the air through the bypass minimises the air-side pressure drop when no mechanical cooling is required.

**Access openings:**

- Tower access door: large access opening for easy access to the cross-flow plate heat exchangers for maintenance and to the components of the adiabatic system.
- Supply air access door: large access opening for easy access to the cooling coil, the bypass damper and the supply air fans for maintenance.

**Control box with ServeUnit controller as part of the Hoval ServeNet control system:**

- Control box made of sheet steel, powder-coated with textured paint in Hoval red (RAL 3000).
- ServeUnit controller fully prewired with the following peripheral components:
  - Feed valve
  - Conductance measurement
  - Bypass damper actuator
  - Extract air combination sensor (temperature, humidity)
  - Energy monitoring combination sensor (temperature, humidity)
  - Filter monitoring extract air
- Control module prewired ready-to-connect with the following peripheral components:
  - Supply air fans
  - Exhaust air fans
  - Liquid level switch
  - Supply air combination sensor (temperature, humidity)
  - Fresh air combination sensor (temperature, humidity)
  - Filter monitoring fresh air
  - Cooling valve
- Fresh air combination sensor (supplied)
- Mains power terminals
- Cable glands designed as cable feedthrough plates

---

**Extract air box**

---

Support frame construction of aluminium sections, attached and bolted, insulated panel construction; fitted with eyelets for crane transport and assembly on site.

The extract air box contains:

**Extract air filter:**

Designed as a G4 class bag filter, including differential pressure switches for filter monitoring.

---

**Exhaust air box**

---

Support frame construction of aluminium sections, attached and bolted, insulated panel construction; fitted with eyelets for crane transport and assembly on site.

The exhaust air box contains:

**Exhaust air fans:**

Designed as maintenance-free, direct-drive radial fans with high-efficiency EC motors, backwards-curved, 3D contoured blades and a free-running rotating wheel made of a high-performance composite material; infinitely variable (3 pieces).

---

**Options for the unit**

---

**Extract air filter AM:**

Class M5 extract air filter as compact filter instead of G4 for optimised filtering of the recirculated air.

**Frame height:**

Modified height of the base frame for adapting to the structure of the false floor (820 mm or 900 mm).

**Cooling valve:**

Non-pressure dependent compensating and control valve as automatic combination valve for control and hydraulic balancing, comprising linear control valve, pressure controller with integrated diaphragm and actuator.

**Fresh air box:**

For directly connecting the fresh air intake to the ServeCool unit by means of an insulated air duct produced in a panel design; equipped with legs for adapting to the frame height. The fresh air box contains the fresh air filter, configured as a class M5 compact filter and the fresh air damper for closing the fresh air opening during maintenance work.

---

### ServeNet control system

---

Control system for the energy-optimised operation of Hoval ServeCool, designed as a decentralised system, with the following main features:

- ServeUnit controller integrated in every unit, for autonomous and individual control of the unit, allowing for demand-controlled adaptation to the operating conditions. The components used are tried-and-tested in the industry and are characterised by their very high level of availability. In the event of a fault, it is possible to obtain a standard component quickly as a spare part.
- Simple wiring of the units to a building management system by an interface (Modbus IP) integrated into the ServeUnit controller
- Possibility of visualisation, set value specification, alarm management, group switching or maintenance management via BMS
- Manual switch for local operation in case of failure of the bus communication
- Seamless recording of all relevant parameters and alarm management
- Service access via separate service interface
- Visualisation and control directly on the unit by web browser via HTML interface
- Simple integration into the Datacenter Infrastructure Management (DCIM)
- The following control functions are performed by the ServeUnit controller:
  - Control of the supply air temperature with extract air temperature limiting and fixed setting of the supply air volume flow
  - Fire control: Connection for an external signal to shut the plant down in the event of a fire
- Units are fully prewired, tested and ready to be connected
- Electrical documentation supplied in the control box

---

### Options for the control system

---

#### Controller supply:

Uninterruptible power supply for the ServeUnit controller in case of intermittent electrical power supply outages or frequency fluctuations.

#### Source changeover:

For redundant power supply, it is possible to switch over between two alternative electrical power supply pathways. The switchover time between the two power supplies can be adjusted in seconds. The switchover only takes place if the phase sequence check and phase monitoring enable the switching.

The 'source switchover' option also includes the controller supply (i.e. uninterruptible power supply for the ServeUnit controller).

#### Actuation of humidifier type 1:

Electrical components and software interface for transmission of signals between the Hoval ServeCool and an external humidifier (e.g. 0...10 V or 0...20 mA); electrical components installed in the control box and fully prewired.

#### Actuation of humidifier type 2:

Electrical components installed in the control box and fully prewired for actuation of an ultrasound humidifier with approx. 5 kg/h humidification performance.

#### Protection module:

Surge voltage protection for protecting the unit against surge voltages from atmospheric discharges and switching operations.

---

**Technical data**

---

- Nominal air flow rate supply air: \_\_\_\_\_ m<sup>3</sup>/h
- Nominal air flow rate fresh air: \_\_\_\_\_ m<sup>3</sup>/h
- Cooling capacity: \_\_\_\_\_ kW
  - at supply air temperature: \_\_\_\_\_ °C
  - at supply air humidity: \_\_\_\_\_ % r.h.
  - at fresh air temperature: \_\_\_\_\_ °C
  - at fresh air humidity: \_\_\_\_\_ % r.h.

**Dimensions**

- ServeCool (footprint x height): 2810 x 2825 x 4225 mm
- Maintenance area supply air side: 2825 x 1000 mm
- Maintenance area fresh air side: 2825 x 1200 mm

**Weight**

- ServeCool: 3965 kg

**Electrical connection**

- Supply voltage: 3 x 400 VAC / 50 Hz
- Current consumption: max. 34.4 A
- Power consumption: max. 21.2 kW

**Sound data**

- Sound pressure level at 5 m distance from unit: 60 dB(A)
- Total sound power level: 82 dB(A)

**Plate heat exchanger**

- Fresh air temperature at free cooling limit: \_\_\_\_\_ °C
- Fresh air relative humidity: \_\_\_\_\_ % r.h.
- Extract air temperature: \_\_\_\_\_ °C
- Extract air relative humidity: \_\_\_\_\_ % r.h.
- Heat recovery efficiency dry fresh air side/extract air side at nominal air flow rate: \_\_\_\_\_ / \_\_\_\_\_ %
- Pressure drop fresh air side/extract air side at nominal air flow rate: \_\_\_\_\_ / \_\_\_\_\_ Pa

**Technical data cooling coil**

- Cooling capacity, total: \_\_\_\_\_ kW
- Cooling capacity, sensitive: \_\_\_\_\_ kW
- Flow/return: \_\_\_\_\_ / \_\_\_\_\_ °C
- Supply air temperature: \_\_\_\_\_ °C
  - for inlet temperature: \_\_\_\_\_ °C
  - with rel. inlet humidity: \_\_\_\_\_ % r.h.
- Operating pressure: \_\_\_\_\_ kPa

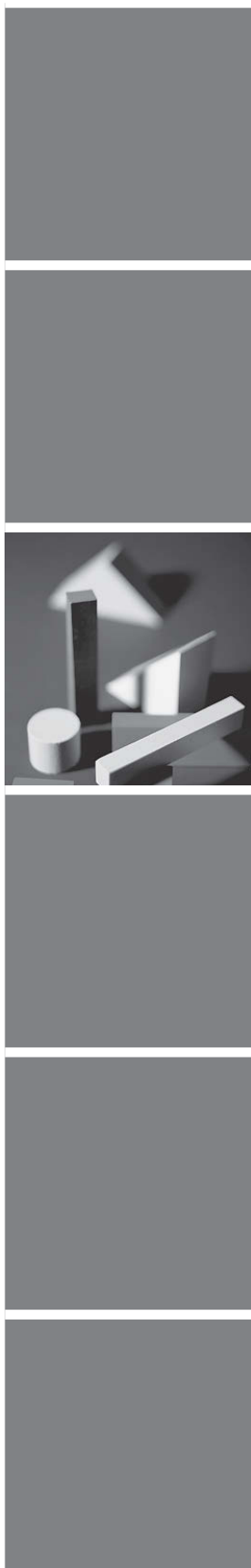

---

## Options

---

C

1 Unit type reference _____	28
2 Extract air filter _____	29
3 Frame height _____	29
4 Cooling valve _____	29
5 Fresh air box _____	30



## 1 Unit type reference

SW - 25 / KS . AG . G1 . KV . AK / QU . B1 . SM

### Unit type

SW ServeCool SW  
SWP ServeCool SWP

### Unit size

25

### Cooling coil

Standard

### Extract air filter

AG Extract air filter G4 (standard)  
AM Extract air filter M5

### Frame height

G1 Frame height 1000 mm (standard)  
G2 Frame height 900 mm  
G3 Frame height 820 mm

### Cooling valve

-- Without (standard)  
KV Cooling valve

### Fresh air box

-- Without (standard)  
AK Fresh air box with M5 filter

### Source changeover

-- Without (standard)  
RV Controller supply  
QU Source changeover

### Actuation of humidifier

-- Without (standard)  
B1 Actuation of humidifier type 1  
B2 Actuation of humidifier type 2

### Protection module

-- Without (standard)  
SM Protection module

## 2 Extract air filter AM

An ultrafine dust filter is installed for filtering the extract air (replaces the standard filter).

Filter class	M5
Filter monitoring factory setting	250 Pa

Table C1: Technical data of the extract air filter

## 3 Frame height

The base frame can be supplied in 3 versions to adapt the ServeCool unit to the structure of the false floor.

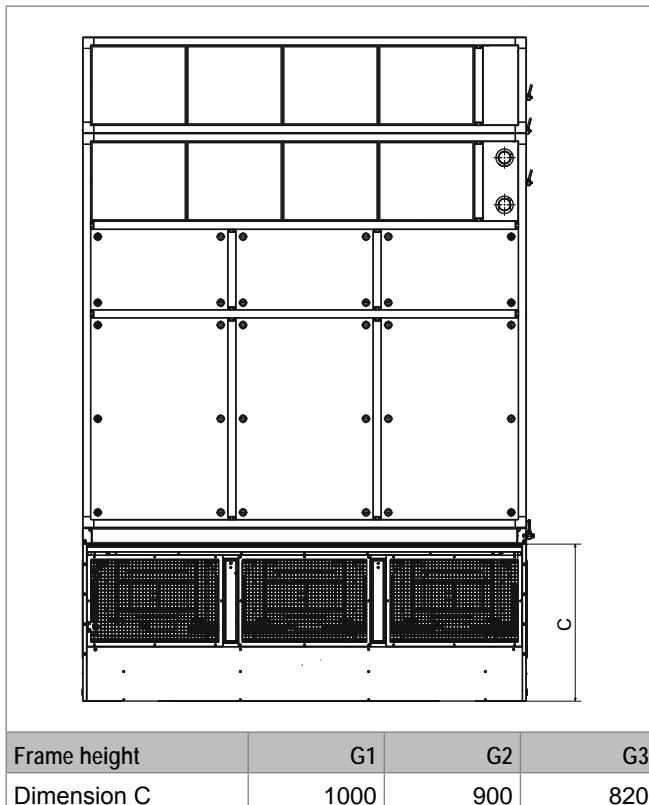

Fig. C1: Dimensional drawing frame height (dimensions in mm)

## 4 Cooling valve

The optionally available cooling valve is a non-pressure-dependent compensating and control valve comprising:

- Linear control valve
- Pressure regulator with integrated diaphragm
- Actuator

The valve is used as an automatic combination valve for control and hydraulic balancing. The valve authority is 100 % ( $a = 1$ ). There is no change in the linear characteristic, irrespective of the settings or the pressure conditions.

Control voltage	0...10 V
Position response	0...10 V
Throughflow rate	28000 l/h

Table C2: Technical data of the cooling valve

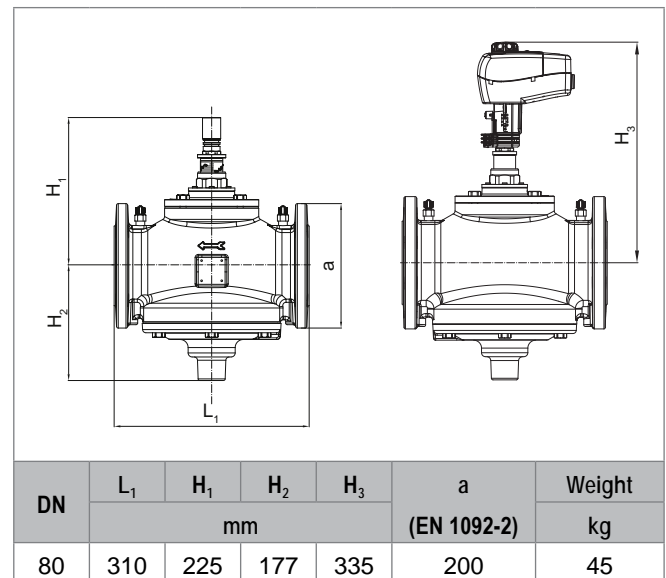

Fig. C2: Dimensional drawing cooling valve

## 5 Fresh air box

The fresh air box is used for directly connecting the fresh air intake to the ServeCool unit by means of an air duct produced in a panel design. The following are installed in the fresh air box:

- Fresh air damper for closing the fresh air opening during maintenance work
- Fresh air filter

Filter class	M5
Filter monitoring factory setting	350 Pa

Table C3: Technical data of the fresh air filter

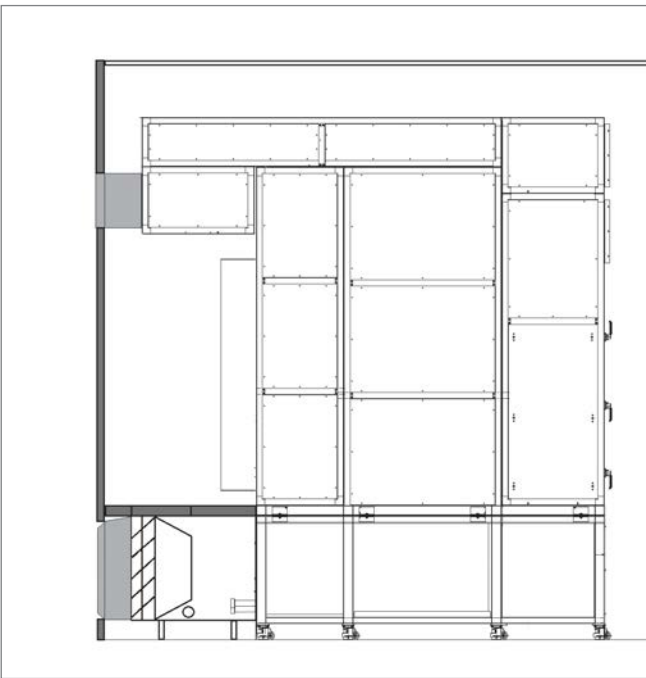
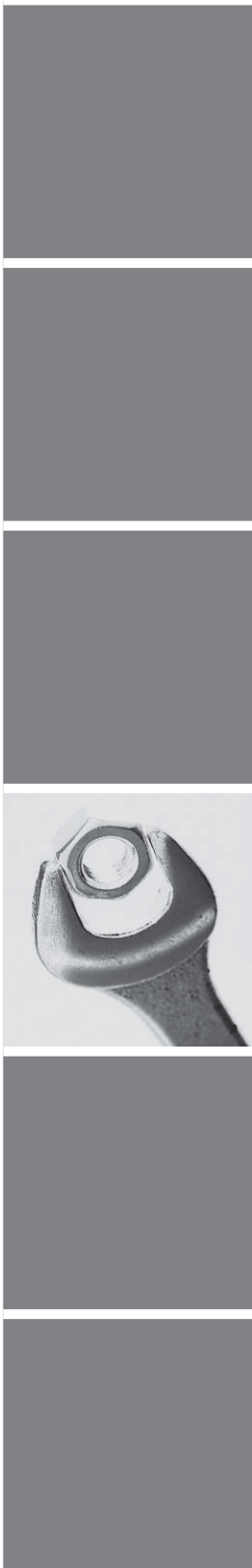

Fig. C3: ServeCool unit with fresh air box



### Notice

You will find a description of the options for the control system in Section E 'Control systems' of this handbook.



---

**Transport and installation**

D

---

1 Installation	32
2 Hydraulic installation	34
3 Electrical installation	36

# 1 Installation

The unit is delivered in 4 or 5 sections on pallets:

- Base frame
- Tower
- Extract air box
- Exhaust air box
- Fresh air box (option)

The following guidelines are important when preparing for installation:

- A crane or a forklift with a fork length of at least 2.4 m is required for lifting and transporting the components.
- For transport to the installation site, it is necessary to have a transport trolley with articulated steering, turntable and drawbar (max. height 110 mm).
- For fine positioning, 2 lift trolleys are required, with a fork length of at least 800 mm and a safe working load of 2000 kg each (recommended lifting range 85...200 mm).
- Follow the installation instructions included.

## 1.1 Installation site

- The unit must be erected at an inside location that is protected against frost.
- Install the unit horizontally.
- Ensure that the installation surface is of sufficient load-bearing capacity. The weight of the unit is distributed over 4 points (see Fig. D1).
- Position the unit in accordance with the airflow direction.
- The unit must be accessible and connecting lines must be able to be dismantled for maintenance and servicing work.

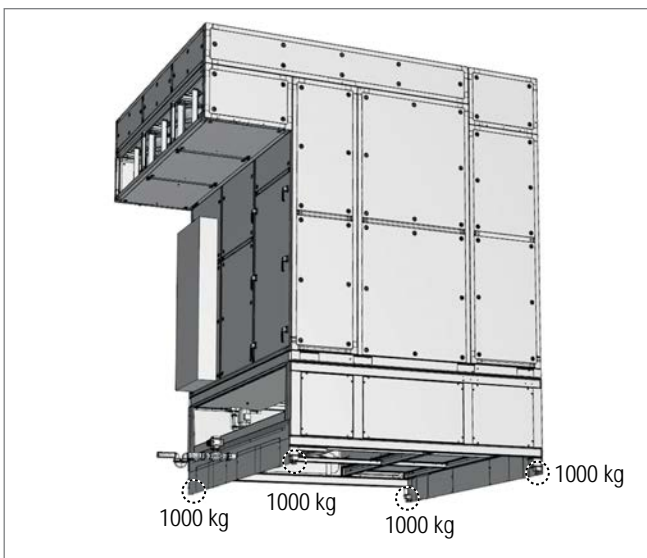

Fig. D1: Load distribution

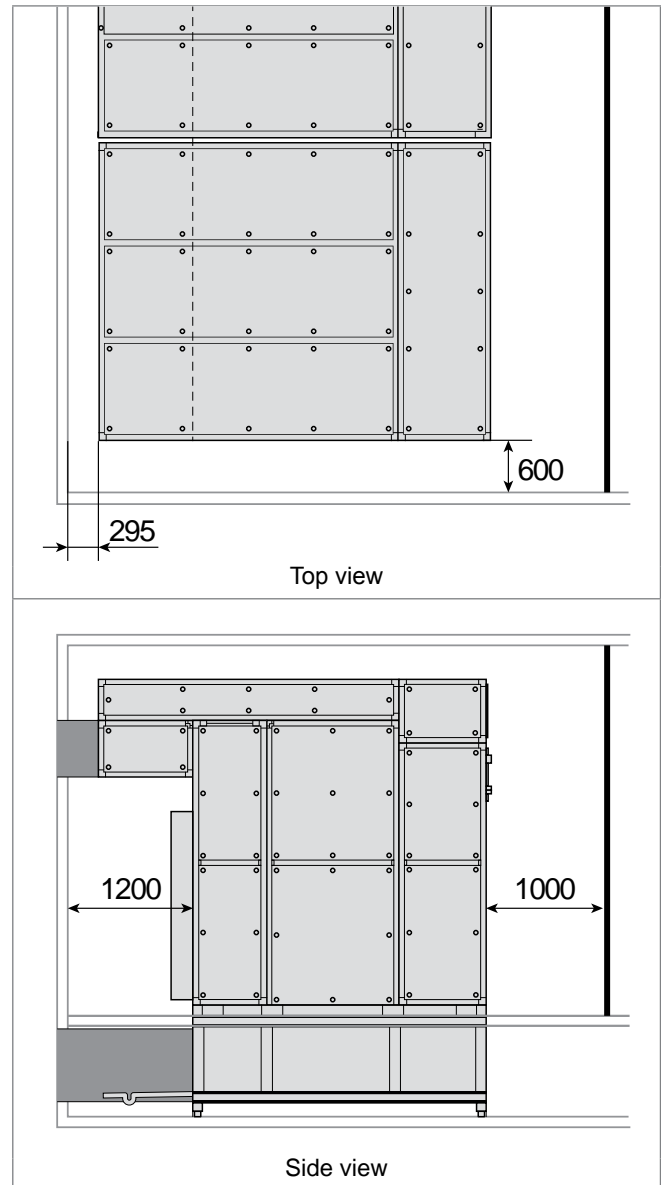

Fig. D2: Space requirements for maintenance and servicing (minimum clearances in mm)

## 1.2 Connecting the air ducts

- Connect the ServeCool unit to fresh air and extract air ducts installed on site.
- The connection to extract air and supply air ducts installed on site depends on the specific conditions of the plant. Ideally, the unit will draw the extract air directly from the server room and blow air back into the false floor directly.
- If an extract air duct is connected, it must be equipped with inspection openings for the filter change (dimension of the extract air filter: 592 mm × 592 mm).
- The unit must not be subjected to the weight of the ducts. Suspend the ducts from the ceiling or support them on the floor.
- Connect the air ducts via the compensators so they are free of tension and vibrations.
- Insulate the fresh air duct including compensator up to the building entry point.



**Note**

If the ServeCool unit is not equipped with the optional fresh air box, the fresh air must be filtered using systems supplied by the client (filter class M5).

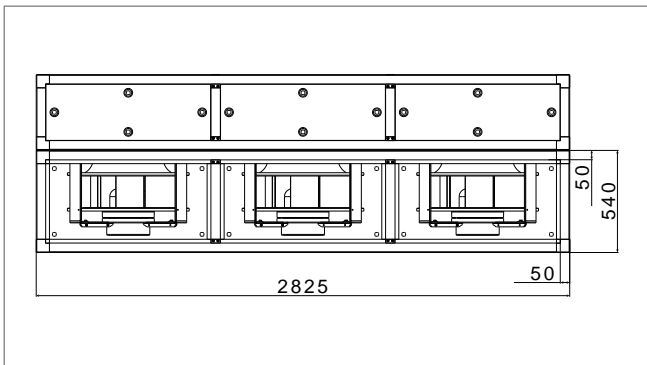

Fig. D3: Dimensional drawing for exhaust air duct (dimensions in mm)

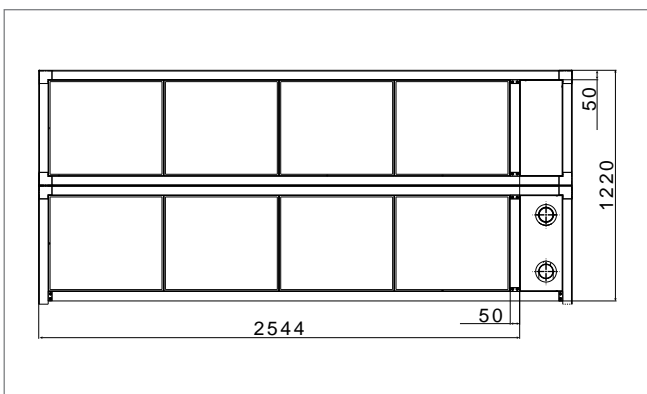
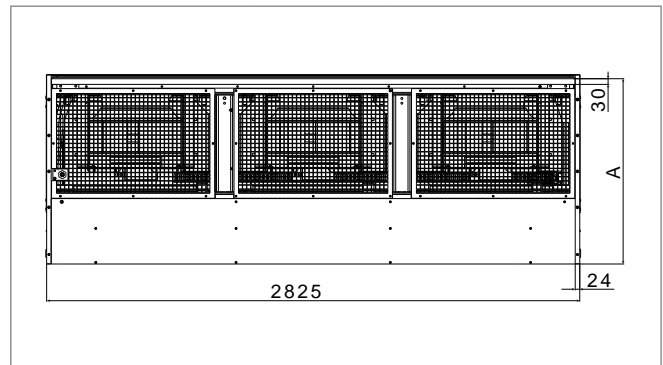

Fig. D4: Dimensional drawing for extract air duct (dimensions in mm)



Frame height	G1	G2	G3
Dimension A	980	880	800

Fig. D5: Dimensional drawing for supply air duct (dimensions in mm)

D

## 2 Hydraulic installation

### 2.1 Cooling coil

- Connect the cooling coil in accordance with the hydraulic diagram.
- Depending on local conditions, check whether compensators for linear expansion are required for the supply and return lines and/or articulated connections are required for the units.

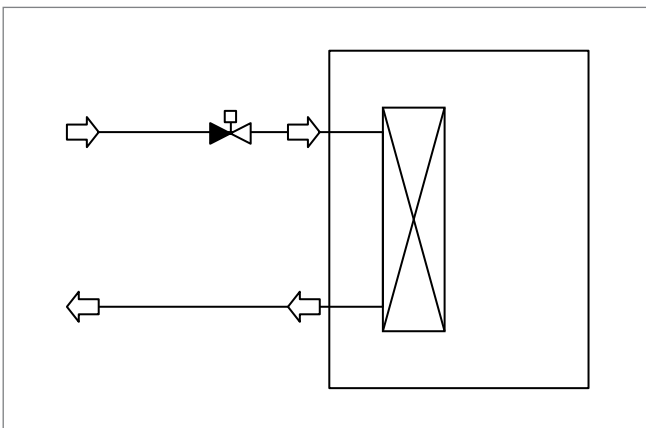

Fig. D6: Connection of the cooling coil

### 2.2 Condensate connection

Condensate arising in the unit must be removed via a condensate line.

- Dimension the slope and cross-section of the condensate line so that no condensate backflow takes place.
- Make sure that the condensate can drain off freely.
- The unit already includes a trap function, so there is no need to provide this function externally.
- Fill the traps (plate heat exchanger and cooling coil) with water before commissioning, after each cleaning operation and after an extended downtime.

Technical data	
Condensate connection	G ½" internal thread
Condensate quantity	max. 7 kg/h

Table D1: Condensate connection

### 2.3 Adiabatic system



**Note**

Comply with national regulations on drinking water protection. Decouple the adiabatic system from the drinking water system to prevent backflow, force-back or suck-back of impurities into the drinking water.

**Water supply**

- Connect the ServeCool unit to the supply of fully demineralised water.
- Use suitable materials for the supply line (recommended: stainless steel, PE or PVC).
- Depending on local conditions, check whether a compensator and/or articulated connection for linear expansion is required for the supply line.

Technical data		
Supply pressure	Recommended	2 bar
	max.	5 bar
Water supply quantity	max.	2 m³/h
Supply line connection	G 1" internal thread	

Table D2: Fully demineralised water supply

Fully demineralised water volume flow						
Supply pressure	0.5	1	2	3	5	bar
Volume flow	360	511	720	878	1138	l/h

Table D3: Water flow through adiabatic system

**Discharge**

- Dimension the slope and cross-section of the discharge pipe so that there is no backing-up of water.
- Make sure that the water can drain off freely.
- Fill the trap with water before commissioning, after each cleaning operation and after an extended downtime.



## 2.4 Water quality

Recommended guidance values for the composition of the circulating water when the unit is operated with a full demineralisation system / reverse osmosis system:

Appearance	clear, colourless, without sediment		
pH value			7 - 8.5
Electric conductance at 20 °C		µS/cm	< 250
Total hardness	TH	°dH	< 1
Chloride	Cl <sup>-</sup>	g/m <sup>3</sup>	< 20
Sulphate	SO <sub>4</sub> <sup>2-</sup>	g/m <sup>3</sup>	< 20
Iron	Fe	mg/l	≤ 0.1
Copper	Cu	mg/l	< 1
Colony count		CFU/ml	< 1000
Legionella		CFU/100 ml	< 100
Concentration figure			5 - 10

Table D4: Composition of the circulation water

### 3 Electrical installation

- Observe all applicable regulations (e.g. EN 60204-1).
- For long supply lines, select cable cross-sections in accordance with the technical regulations.
- Electrical installation to be carried out according to wiring diagram.
- Route the cables for the control systems separately from mains cables.
- Wire up peripheral components installed in the base frame, in the extract air box and in the exhaust air box to the plug connections in the control box.
- The fresh air combination sensor (temperature, humidity) is supplied loose in the control panel. Install the sensor at a suitable location and wire it to the plug connections in the control box.
- Secure all connections against working loose.

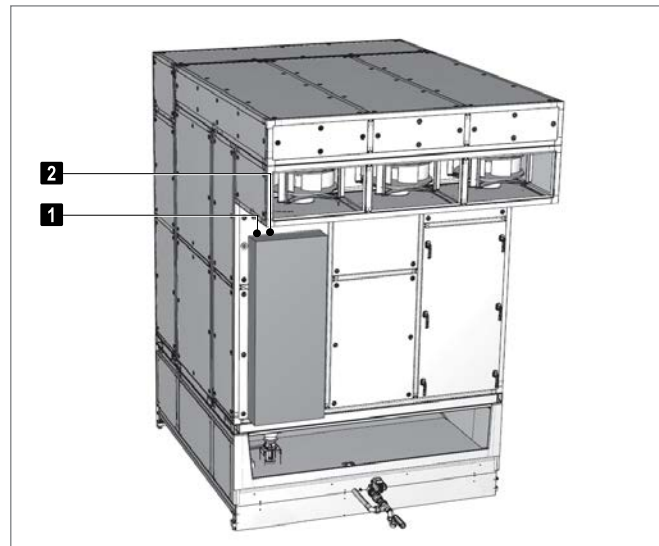

**1** Cable feedthrough for power supply

**2** Cable feedthrough for bus cable

Fig. D7: Electrical installation

Designation	Reference	Voltage	Cable	Remark
Power supply		3 x 400 VAC		NYM, max. fusing 40 A
Operation and control	Web browser		CAT5e RJ45	
	BMS integration		CAT5e RJ45	Modbus IP
External signals	Operating signal	24 V / 230 V	2 x 1.0 mm <sup>2</sup>	Volt-free, 8 A
	Collective fault signal	24 V / 230 V	2 x 1.0 mm <sup>2</sup>	Volt-free, 8 A
Fresh air combination sensor			2 x 2 x 0.8 mm <sup>2</sup>	4...20 mA JYSTY (cable supplied)
Filter monitoring fresh air		Volt-free	2 x 2 x 0.8 mm <sup>2</sup>	JYSTY (cable supplied)
Fire control		Volt-free		NYM
Options				
Cooling valve			2 x 2 x 0.8 mm <sup>2</sup>	JYSTY, incl. control voltage and position response
Actuation of humidifier type 1	Continuous control		2 x 2 x 0.8 mm <sup>2</sup>	0...10 V JYSTY
	Power supply and control	48 VAC	7 x 1.5 mm <sup>2</sup>	Up to max. 320 VA, NYM, max. 8 m cable length
Actuation of humidifier type 2	Discharge solenoid valve	48 VAC	3 x 1.0 mm <sup>2</sup>	NC valve, NYM cable
	Hygrostat for maximum humidity limiting	24 VDC	2 x 1.0 mm <sup>2</sup>	NYM

Table D5: Cable list for on-site connections

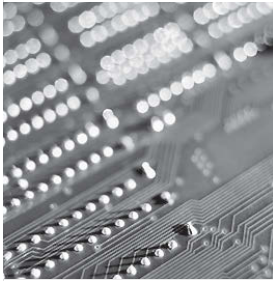

1	ServeNet system set-up	38
2	Control functions	39
3	Safety functions	40
4	Control options	40
5	Alarms and monitoring	40

---

## Control systems

---

E

## 1 ServeNet system set-up

The Hoval ServeNet control system controls the ServeCool units fully automatically. Depending on the ambient conditions, it controls the interplay between the individual cooling processes and thus ensures demand-driven operation with optimised use of energy.

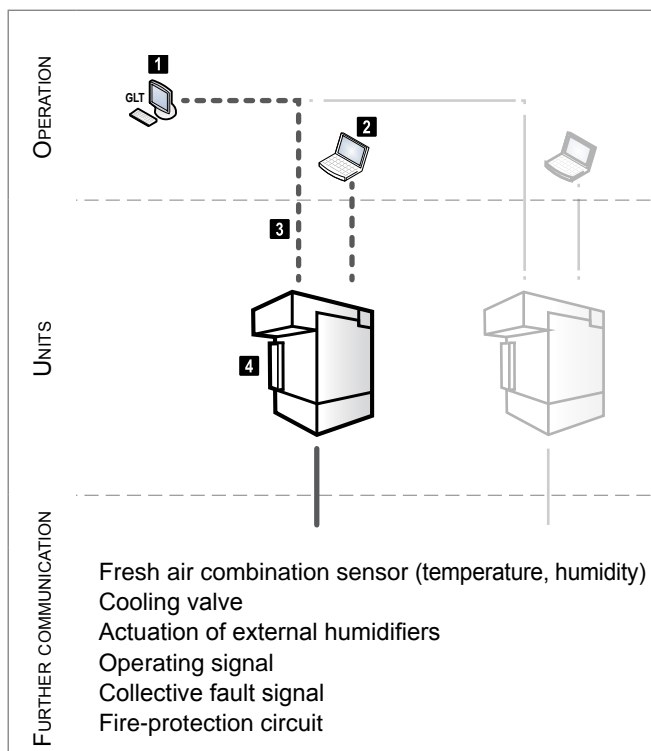

- 1** Building management system
- 2** Web browser
- 3** Modbus IP
- 4** Control box with ServeUnit controller

Fig. E1: ServeNet system set-up

### 1.1 Basic data

A ServeUnit controller is installed in the control box of each ServeCool unit for autonomous and individual control.

#### Control box front panel

The following are installed in the control box front panel:

- Main switch
- Control mode switch (local mode / BMS switchover)
- Alarm reset key
- Operation indicator light (green)
- Malfunction indicator light (red)
- HTML interface

3 volt-free signalling contacts are available for a higher-level system:

- Operating signal
- Collective fault signal
- Fire-protection circuit

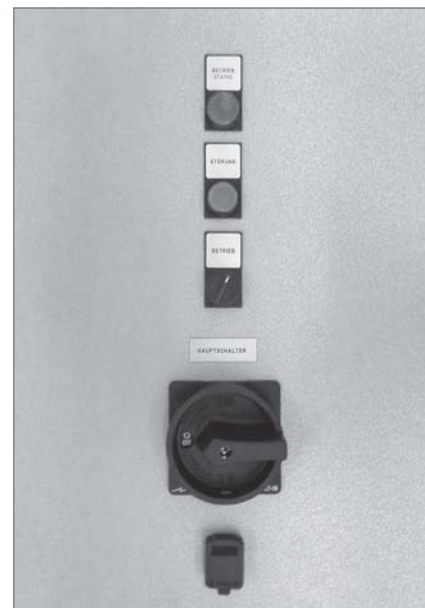

Fig. E2: Display and operating elements in the control box front panel

## 1.2 Operation

### Operation via web browser

The web visualisation of the ServeNet control system can be displayed on any web browser. The operator terminal is a computer connected to the HTML interface in the control box front panel.

The web visualisation offers the following functions:

- Display and setting of operating modes
- Display of temperatures and humidities
- Display and setting of set values and control parameters
- Programming
- Display and handling of alarms and maintaining an alarm log
- Recording trends
- Differentiated password protection for various operator levels

### Integration into the building management system (BMS)

ServeNet can be easily integrated into the building management system. The data is exchanged via Modbus IP. A full parameter list is available on request.

## 1.3 Control mode

2 different control modes are available in ServeNet:

LOCAL MODE	The ServeUnit controller operates autonomously according to the specifications from the internal memory.
BMS MODE	The ServeUnit controller operates according to the specifications from the building management system. The following set values can be specified independently of one another: <ul style="list-style-type: none"> <li>■ Operating mode</li> <li>■ Supply air temperature</li> <li>■ Supply air humidity</li> <li>■ Supply air volume flow</li> </ul>

Local mode is activated or deactivated using the control mode switch in the control box front panel.

## 2 Control functions

### 2.1 Supply air temperature control

The ServeUnit controller controls the supply air conditions:

- Supply air temperature
- Supply air humidity (optional, only humidification)

Depending on the current operating mode (winter or summer mode) and the current temperature and moisture conditions, the ServeUnit controller controls the interplay of the following components:

- Exhaust air fans for indirect free cooling
- Water circuit for adiabatic cooling
- Cooling valve and position of the bypass damper for mechanical cooling

### 2.2 Extract air temperature limiting

Extract air temperature limiting reduces the set value for the supply air temperature to an adjustable minimum value according to the extract air temperature.

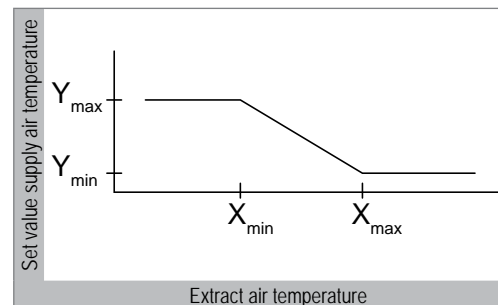

Diagram E1: Extract air temperature limiting

### 2.3 Supply air volume flow

The ServeUnit controller controls the speed of the supply air fans according to the specified set value.

## 3 Safety functions

### 3.1 Fire-protection circuit

Connection for an external signal to shut the plant down in the event of a fire

### 3.2 Ground fault monitoring

The ground fault monitoring of the 24 V control voltage signals earthed normal operation and, following opening of the disconnect slider in the OFF position, signals whether there is a ground fault in the circuit.

## 4 Control options

### 4.1 Controller supply

Uninterruptible power supply for the ServeUnit controller in case of intermittent electrical power supply outages or frequency fluctuations.

### 4.2 Source changeover

For redundant power supply, it is possible to switch over between two alternative electrical power supply pathways. The switchover time between the two power supplies can be adjusted in seconds. The switchover only takes place if the phase sequence check and phase monitoring enable the switching.

The 'source switchover' option also includes the controller supply (i.e. uninterruptible power supply for the ServeUnit controller).

### 4.3 Actuation of humidifier type 1

Electrical components and software interface for transmission of signals between the Hoval ServeCool and an external humidifier (e.g. 0...10 V or 0...20 mA); electrical components installed in the control box and fully prewired.

### 4.4 Actuation of humidifier type 2

Electrical components installed in the control box and fully prewired for actuation of an ultrasound humidifier with approx. 5 kg/h humidification performance.

### 4.5 Protection module

Surge voltage protection for protecting the unit against surge voltages from atmospheric discharges and switching operations.

## 5 Alarms and monitoring

The Hoval ServeNet monitors itself. All alarms are registered in the alarm list and displayed by the visualisation on the web browser or in the building management system. A full alarm list is available on request.



1 Design example _____	44
2 Cooling capacities _____	48
3 Recommended extract air humidity _____	56
4 Maintenance schedule _____	57
5 h,x diagram _____	58

---

System design

# 1 Design example

## 1.1 Design

Design data	Example
<ul style="list-style-type: none"> <li>IT infrastructure</li> <li>Heat load</li> </ul>	<p>Server room with 60 racks                      Dimensions of the racks W x H x D = 800 x 2200 x 1000 mm</p> <p>8 kW per rack                      60 x 8 kW = 480 kW</p>
<ul style="list-style-type: none"> <li>Supply and extract air conditions</li> </ul> <div data-bbox="145 846 719 1032" style="border: 1px solid black; padding: 5px; margin-top: 10px;"> <p><b>i Note</b>                      Optimised operating conditions with regard to energy costs are:</p> <ul style="list-style-type: none"> <li>Highest possible supply air temperature</li> <li>Greatest possible temperature difference between supply air and extract air</li> </ul> </div>	<p>Recommendation: air conditions acc. to ASHRAE TC 9.9 A1:</p> <div data-bbox="751 813 1406 1328" style="border: 1px solid black; padding: 5px; margin-top: 10px;"> </div> <p>Fig. F1: Recommended air conditions in the server room acc. to ASHRAE TC 9.9 A1, represented in the hx diagram</p> <ul style="list-style-type: none"> <li>Air conditions at the server inlet:..... max. 26 °C / 35 % r.h.</li> <li>Extract air conditions: ..... max. 38 °C / 18 % r.h.</li> </ul>
<ul style="list-style-type: none"> <li>Site and configuration conditions</li> </ul> <p>The configuration conditions are based on statistical meteorological data for the location of the data centre (acc. to VDI 4710).</p> <div data-bbox="145 1720 719 1883" style="border: 1px solid black; padding: 5px; margin-top: 10px;"> <p><b>i Note</b>                      For additional safety even under extreme weather conditions, it may be sensible to assume a higher fresh air temperature and humidity in the configuration.</p> </div>	<p>Location: Frankfurt am Main (DE)</p> <p>For Frankfurt, the following average fresh air conditions apply for the configuration of cooling units: 35 °C / 22 % r.h.</p>
<p><b>Supply air conditions</b>                      To define the supply air temperature, reduce the permitted air temperature at the server inlet by 2 K. Read off the corresponding humidity from the hx diagram (see Fig. F1).</p>	<p>→ Supply air conditions: 24 °C / 40 % r.h.</p>



<p><b>Total cooling capacity per unit (<math>Q_{tot}</math>)</b> The total cooling capacity per ServeCool unit depends on the temperature difference (<math>\Delta t</math>) between the supply air and extract air. Read off the total cooling capacity from Table F2.</p>	<p><math>\Delta t = 38 - 24 = 14 \text{ K}</math>  → Total cooling capacity per unit <math>Q_{tot}</math>: 120 kW</p>
<p><b>Required number of units (n)</b> ■ The heat load divided by the total cooling capacity per unit defines the required number of units for cooling the server room.</p>	<p><math>n = 480 \text{ kW} : 120 \text{ kW} = 4</math></p>
<p>■ An additional, redundant unit is installed to ensure the cooling capacity is achieved even if a unit fails. This guarantees high availability of the overall system.</p>	<p>→ <math>4 + 1 = 5</math> units are installed.</p>
<p><b>Cold supply for mechanical cooling</b> The total cooling capacity per unit <math>Q_{tot}</math> is composed of: – capacity of the free and adiabatic cooling (<math>Q_F</math>) – capacity of the mechanical cooling (<math>Q_M</math>)</p>	
<p>■ From the hx diagram, find the absolute humidity under configuration conditions.</p>	<p>35 °C / 22 % r.h. → Absolute humidity: 7.7 g/kg</p>
<p>■ Use the information in Table F2 to ascertain what mechanical cooling capacity per unit (<math>Q_M</math>) is required under configuration conditions.</p>	<p><math>Q_F</math> acc. to table = 108 kW <math>Q_M = Q_{tot} - Q_F</math> <math>Q_M = 120 \text{ kW} - 108 \text{ kW} = 12 \text{ kW}</math></p>
<p>■ Multiply this value by the required number of units (n) to calculate the total mechanical cooling capacity required.</p>	<p><math>4 \times 12 \text{ kW} = 48 \text{ kW}</math> For redundant supply, 2 chilled water systems with 48 kW cooling capacity each are provided.</p>
<p>■ Select the flow/return temperature and, with reference to the mechanical cooling capacity per unit (<math>Q_M</math>), read off the corresponding water quantity and water pressure drop from Table F8.</p>	<p>For flow/return 14/20 °C and 30 % glycol, the following applies: <math>m_w = 1873 \text{ l/h}</math> <math>\Delta p_w = 0.44 \text{ kPa}</math></p>

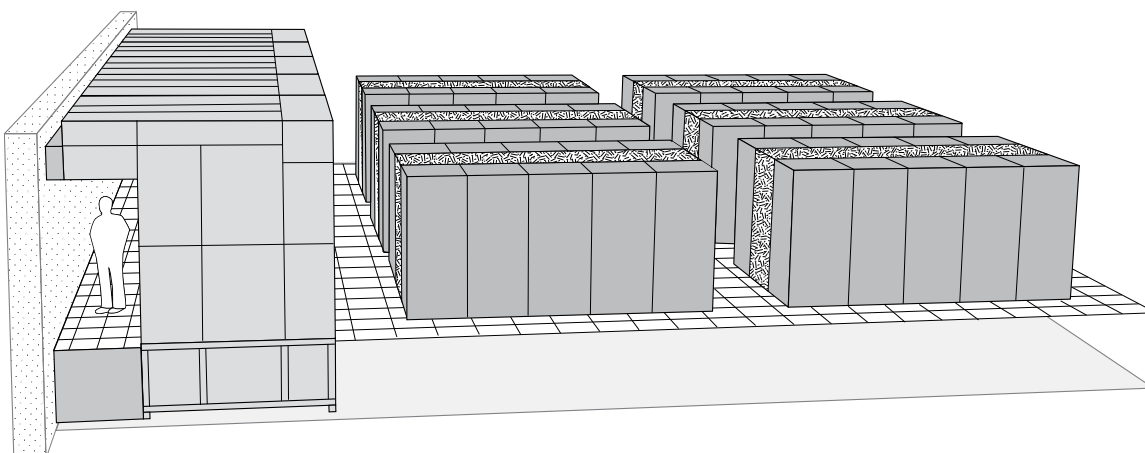

Fig. F2: Schematic diagram of a data centre

1.2 Location

The units are positioned at the end of the server room in a line of technological equipment.

- IT area ..... 165 m<sup>2</sup>
- Technological equipment ..... 78 m<sup>2</sup>
- Specific load distribution ..... 2.9 kW/m<sup>2</sup>

The supply air is distributed throughout the room via the false floor, and the extract air is extracted from under the ceiling. The cold aisle containment prevents the supply air from mixing with the extract air, thereby guaranteeing efficient air conditioning.

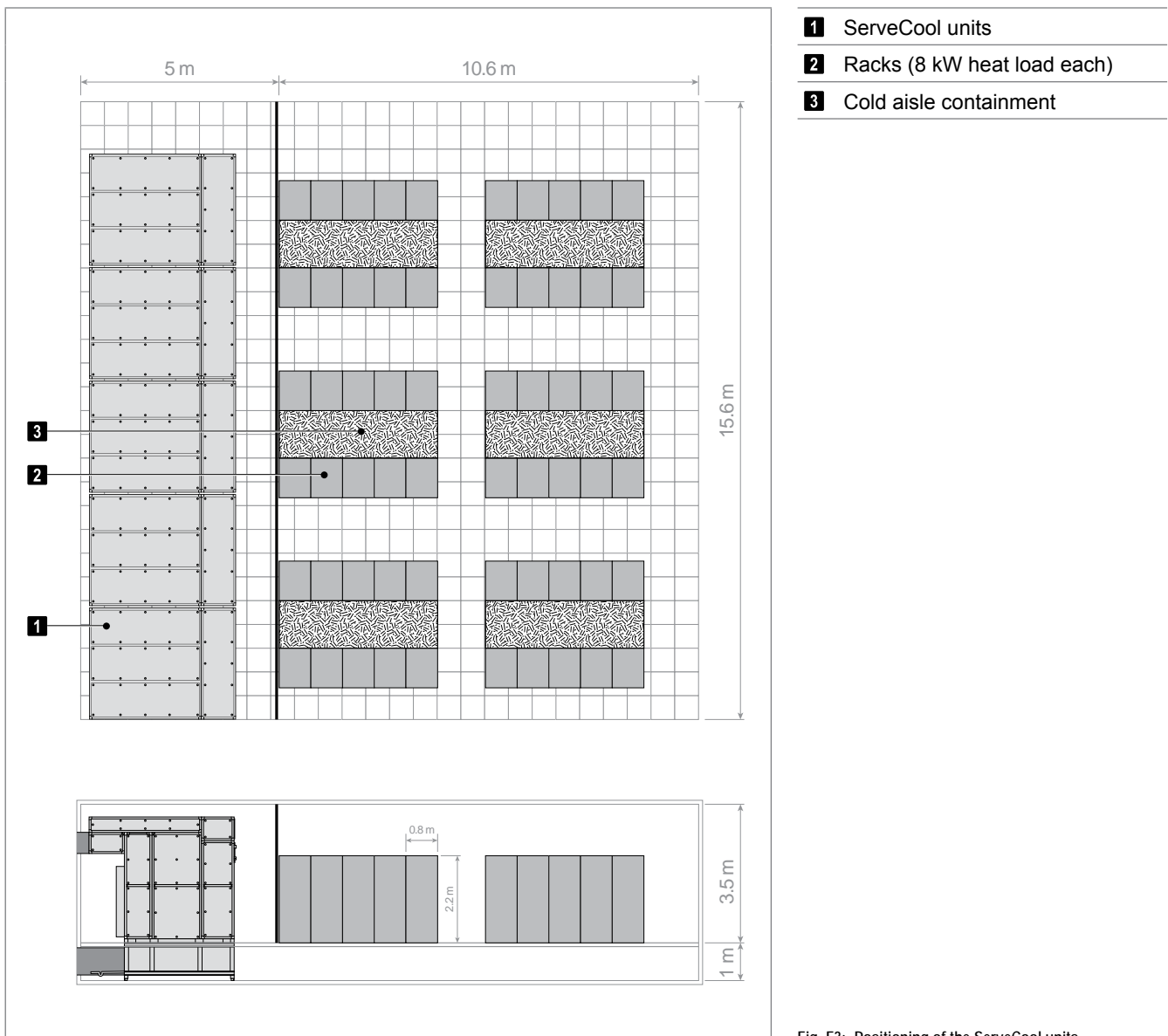

Fig. F3: Positioning of the ServeCool units

### 1.3 Water treatment

The adiabatic cooling requires a fully demineralised water supply. For treating the fully demineralised water, Hoval recommends using a reverse osmosis system which pumps into separately installed water tanks. Guidance values for the water consumption are specified in Table F1.

Month	Water consumption in l/h							
	Mar	Apr	May	Jun	Jul	Aug	Sep	Oct
Maximum	61	97	131	150	176	150	120	45
Medium	47	69	86	95	102	86	74	34
Minimum	30	25	30	25	30	25	25	25

Table F1: Water consumption for evaporative cooling per ServeCool unit (reference values for Germany)

- Assuming the average water consumption in July, this results in:  
 $102 \text{ l/h} \cdot 24 \text{ h} = 2448 \text{ l} \rightarrow \text{approx. } 2.5 \text{ m}^3 \text{ per day}$
- Multiplied by the necessary number of units  $n = 4$ , this produces a daily consumption of approx.  $10 \text{ m}^3$  fully demineralised water.

To provide a day's reserve, a storage tank with approx.  $10 \text{ m}^3$  volume is installed. For the purposes of redundancy, the storage tank is equipped with a municipal water supply.



**Note**

Take account of the local water conditions when configuring and dimensioning the water treatment. The example shown here is intended for guidance. If possible, the redundancy concept should include use of municipal water.



**Note**

If you want to ensure safe operation of the system even if the water supply fails, the mechanical cooling capacity of the unit must be sufficient to cover peak loads without adiabatic cooling. Check the required capacity of the cooling coil and dimension the chilled water system accordingly.

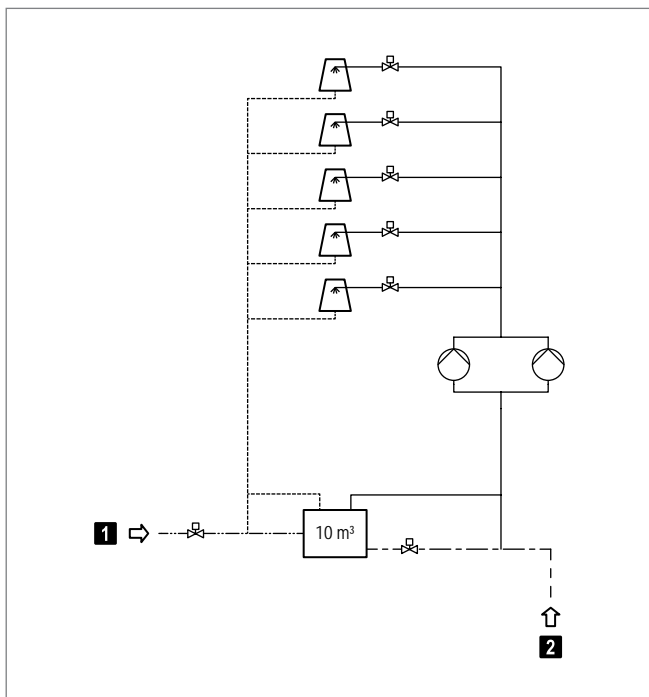

1 Reverse osmosis system 300 l/h

2 Municipal water supply

Fig. F4: On site water treatment for ServeCool SW

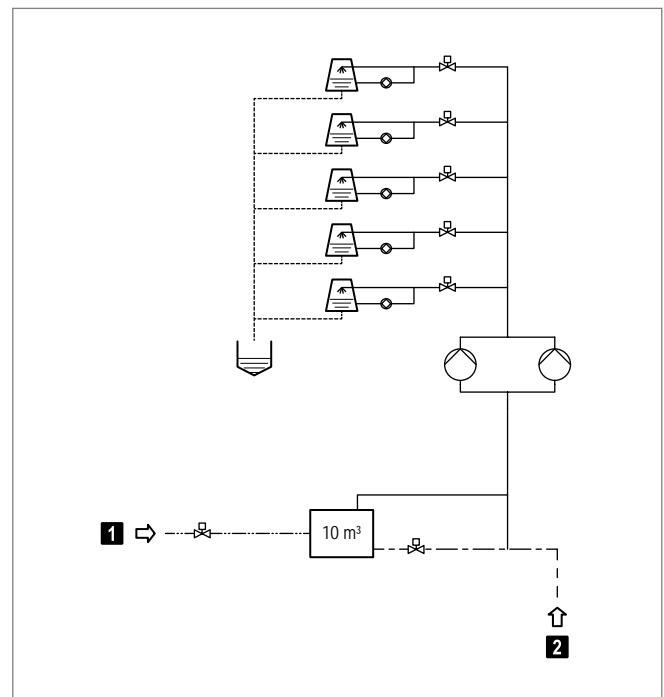

1 Reverse osmosis system 300 l/h

2 Municipal water supply

Fig. F5: On site water treatment for ServeCool SWP

## 2 Cooling capacities

### 2.1 Free and adiabatic cooling

Extract air: <b>38 °C</b>	Supply air: <b>24 °C</b>	<b><math>\Delta t = 14 \text{ K}</math></b>	<b><math>Q_{\text{tot}} = 120 \text{ kW}</math></b>																		
Fresh air																					
t \ x	0,1	1	2	3	4	5	6	7	8	9	10	11	12	13	14	15	16	17	18	19	20
≤17	120	120	120	120	120	120	120	120	120	120	120	120	120	120	120	120	120	120	120	120	120
18	120	120	120	120	120	120	120	120	120	120	120	120	120	117	117	117	117	117	117	117	117
19	120	120	120	120	120	120	120	120	120	120	120	120	117	114	111	111	111	111	111	111	111
20	120	120	120	120	120	120	120	120	120	120	120	120	117	111	108	105	105	105	105	105	105
21	120	120	120	120	120	120	120	120	120	120	120	120	114	111	105	102	100	100	100	100	100
22	120	120	120	120	120	120	120	120	120	120	120	117	114	108	102	100	97	94	94	94	94
23	120	120	120	120	120	120	120	120	120	120	120	114	111	105	102	97	94	91	88	88	88
24	120	120	120	120	120	120	120	120	120	120	117	114	108	105	100	97	91	88	85	82	82
25	120	120	120	120	120	120	120	120	120	120	117	111	108	102	100	94	91	88	82	79	76
26	120	120	120	120	120	120	120	120	120	120	114	111	105	102	97	94	88	85	82	76	73
27	120	120	120	120	120	120	120	120	120	117	111	108	102	100	94	91	88	82	79	76	73
28	120	120	120	120	120	120	120	120	120	114	111	105	102	97	94	91	85	82	79	73	70
29	120	120	120	120	120	120	120	120	117	114	108	105	100	97	91	88	85	79	76	73	70
30	120	120	120	120	120	120	120	120	117	111	108	102	100	94	91	85	82	79	76	70	67
31	120	120	120	120	120	120	120	120	114	111	105	100	97	94	88	85	82	76	73	70	67
32	120	120	120	120	120	120	120	117	111	108	102	100	94	91	88	82	79	76	73	67	64
33	120	120	120	120	120	120	120	114	111	105	102	97	94	91	85	82	79	73	70	67	64
34	120	120	120	120	120	120	117	114	108	105	100	97	91	88	85	79	76	73	70	67	62
35	120	120	120	120	120	120	117	111	108	102	100	94	91	85	82	79	76	70	67	64	62
36	120	120	120	120	120	120	114	111	105	100	97	94	88	85	82	76	73	70	67	64	62
37	120	120	120	120	120	117	111	108	102	100	94	91	88	82	79	76	73	67	64	62	59
38	120	120	120	120	120	114	111	105	102	97	94	88	85	82	79	73	70	67	64	62	59
39	120	120	120	120	117	114	108	105	100	97	91	88	85	79	76	73	70	67	62	59	56
40	120	120	120	120	117	111	108	102	100	94	91	85	82	79	76	70	67	64	62	59	56
41	120	120	120	120	114	111	105	100	97	94	88	85	82	76	73	70	67	64	59	56	53
42	120	120	120	117	111	108	102	100	94	91	88	82	79	76	73	67	64	62	59	56	53
43	120	120	120	114	111	105	102	97	94	91	85	82	79	73	70	67	64	62	59	56	50
44	120	120	117	114	108	105	100	97	91	88	85	79	76	73	70	64	62	59	56	53	50
45	120	120	117	111	108	102	100	94	91	85	82	79	76	70	67	64	62	59	56	53	50

Legend: t = Fresh air temperature in °C  
x = Fresh air humidity in g/kg

Table F2: Cooling capacities in kW of the free and adiabatic cooling ( $Q_f$ )

Extract air: 33 °C

Supply air: 21 °C

$\Delta t = 12 \text{ K}$

$Q_{\text{tot}} = 103 \text{ kW}$

Fresh air																					
t \ x	0,1	1	2	3	4	5	6	7	8	9	10	11	12	13	14	15	16	17	18	19	20
≤15	103	103	103	103	103	103	103	103	103	103	103	103	103	103	103	103	103	103	103	103	103
16	103	103	103	103	103	103	103	103	103	103	103	99	99	99	99	99	99	99	99	99	99
17	103	103	103	103	103	103	103	103	103	103	103	99	94	94	94	94	94	94	94	94	94
18	103	103	103	103	103	103	103	103	103	103	102	96	90	88	88	88	88	88	88	88	88
19	103	103	103	103	103	103	103	103	103	103	103	99	94	88	85	82	82	82	82	82	82
20	103	103	103	103	103	103	103	103	103	103	103	96	90	88	82	79	76	76	76	76	76
21	103	103	103	103	103	103	103	103	103	103	99	94	90	85	82	76	73	71	71	71	71
22	103	103	103	103	103	103	103	103	103	103	96	94	88	85	79	73	71	67	65	65	65
23	103	103	103	103	103	103	103	103	102	96	90	85	82	76	73	67	65	62	59	59	59
24	103	103	103	103	103	103	103	103	99	94	88	85	79	76	71	67	62	59	56	53	53
25	103	103	103	103	103	103	103	102	96	90	88	82	79	73	71	65	62	59	53	50	47
26	103	103	103	103	103	103	103	99	94	90	85	82	76	73	67	65	59	56	53	47	44
27	103	103	103	103	103	103	103	96	94	88	82	79	73	71	65	62	59	53	50	47	44
28	103	103	103	103	103	103	102	96	90	85	82	76	73	67	65	62	56	53	50	44	41
29	103	103	103	103	103	103	99	94	88	85	79	76	71	67	62	59	56	50	47	44	41
30	103	103	103	103	103	102	96	90	88	82	79	73	71	65	62	56	53	50	47	41	38
31	103	103	103	103	103	99	94	90	85	82	76	71	67	65	59	56	53	47	44	41	38
32	103	103	103	103	103	96	94	88	82	79	73	71	65	62	59	53	50	47	44	38	35
33	103	103	103	103	102	96	90	85	82	76	73	67	65	62	56	53	50	44	41	38	35
34	103	103	103	103	99	94	88	85	79	76	71	67	62	59	56	50	47	44	41	38	32
35	103	103	103	103	96	90	88	82	79	73	71	65	62	56	53	50	47	41	38	35	32
36	103	103	103	99	94	90	85	82	76	71	67	65	59	56	53	47	44	41	38	35	32
37	103	103	103	99	94	88	82	79	73	71	65	62	59	53	50	47	44	38	35	32	29
38	103	103	102	96	90	85	82	76	73	67	65	59	56	53	50	44	41	38	35	32	29
39	103	103	99	94	88	85	79	76	71	67	62	59	56	50	47	44	41	38	32	29	26
40	103	103	96	90	88	82	79	73	71	65	62	56	53	50	47	41	38	35	32	29	26
41	103	99	94	90	85	82	76	71	67	65	59	56	53	47	44	41	38	35	29	26	23
42	103	99	94	88	82	79	73	71	65	62	59	53	50	47	44	38	35	32	29	26	23
43	99	96	90	85	82	76	73	67	65	62	56	53	50	44	41	38	35	32	29	26	20
44	99	94	88	85	79	76	71	67	62	59	56	50	47	44	41	35	32	29	26	23	20
45	96	94	88	82	79	73	71	65	62	56	53	50	47	41	38	35	32	29	26	23	20

Legend: t = Fresh air temperature in °C  
x = Fresh air humidity in g/kg

Table F3: Cooling capacities in kW of the free and adiabatic cooling ( $Q_f$ )

Extract air: 36 °C      Supply air: 21 °C       $\Delta t = 15 \text{ K}$        $Q_{\text{tot}} = 129 \text{ kW}$

Fresh air																					
t \ x	0,1	1	2	3	4	5	6	7	8	9	10	11	12	13	14	15	16	17	18	19	20
≤14	129	129	129	129	129	129	129	129	129	129	129	129	129	129	129	129	129	129	129	129	
15	129	129	129	129	129	129	129	129	129	129	126	123	123	123	123	123	123	123	123	123	
16	129	129	129	129	129	129	129	129	129	129	123	117	117	117	117	117	117	117	117	117	
17	129	129	129	129	129	129	129	129	129	126	120	117	112	111	111	111	111	111	111	111	
18	129	129	129	129	129	129	129	129	129	123	120	114	108	105	105	105	105	105	105	105	
19	129	129	129	129	129	129	129	129	126	123	117	112	105	103	100	100	100	100	100	100	
20	129	129	129	129	129	129	129	129	126	120	114	108	105	100	96	94	94	94	94	94	
21	129	129	129	129	129	129	129	129	123	117	112	108	103	100	94	91	88	88	88	88	
22	129	129	129	129	129	129	129	126	120	114	112	105	103	96	91	88	85	82	82	82	
23	129	129	129	129	129	129	129	123	120	114	108	103	100	94	91	85	82	79	77	77	
24	129	129	129	129	129	129	126	123	117	112	105	103	96	94	88	85	79	77	73	70	
25	129	129	129	129	129	129	126	120	114	108	105	100	96	91	88	82	79	77	70	67	
26	129	129	129	129	129	129	123	117	112	108	103	100	94	91	85	82	77	73	70	65	
27	129	129	129	129	129	126	120	114	112	105	100	96	91	88	82	79	77	70	67	65	
28	129	129	129	129	129	123	120	114	108	103	100	94	91	85	82	79	73	70	67	62	
29	129	129	129	129	126	123	117	112	105	103	96	94	88	85	79	77	73	67	65	62	
30	129	129	129	129	126	120	114	108	105	100	96	91	88	82	79	73	70	67	65	59	
31	129	129	129	129	123	117	112	108	103	100	94	88	85	82	77	73	70	65	62	59	
32	129	129	129	126	120	114	112	105	100	96	91	88	82	79	77	70	67	65	62	56	
33	129	129	129	123	120	114	108	103	100	94	91	85	82	79	73	70	67	62	59	56	
34	129	129	126	123	117	112	105	103	96	94	88	85	79	77	73	67	65	62	59	56	
35	129	129	126	120	114	108	105	100	96	91	88	82	79	73	70	67	65	59	56	53	
36	129	129	123	117	112	108	103	100	94	88	85	82	77	73	70	65	62	59	56	53	
37	129	126	120	117	112	105	100	96	91	88	82	79	77	70	67	65	62	56	53	50	
38	129	123	120	114	108	103	100	94	91	85	82	77	73	70	67	62	59	56	53	50	
39	126	123	117	112	105	103	96	94	88	85	79	77	73	67	65	62	59	56	50	47	
40	126	120	114	108	105	100	96	91	88	82	79	73	70	67	65	59	56	53	50	47	
41	123	117	112	108	103	100	94	88	85	82	77	73	70	65	62	59	56	53	47	44	
42	120	117	112	105	100	96	91	88	82	79	77	70	67	65	62	56	53	50	47	44	
43	117	114	108	103	100	94	91	85	82	79	73	70	67	62	59	56	53	50	47	44	
44	117	112	105	103	96	94	88	85	79	77	73	67	65	62	59	53	50	47	44	41	
45	114	111	105	100	96	91	88	82	79	73	70	67	65	59	56	53	50	47	44	41	

Legend: t = Fresh air temperature in °C  
 x = Fresh air humidity in g/kg

Table F4: Cooling capacities in kW of the free and adiabatic cooling ( $Q_f$ )

Extract air: 36 °C      Supply air: 22 °C       $\Delta t = 14 \text{ K}$        $Q_{\text{tot}} = 120 \text{ kW}$

Fresh air																					
t \ x	0,1	1	2	3	4	5	6	7	8	9	10	11	12	13	14	15	16	17	18	19	20
≤15	120	120	120	120	120	120	120	120	120	120	120	120	120	120	120	120	120	120	120	120	120
16	120	120	120	120	120	120	120	120	120	120	120	117	117	117	117	117	117	117	117	117	117
17	120	120	120	120	120	120	120	120	120	120	120	117	112	111	111	111	111	111	111	111	111
18	120	120	120	120	120	120	120	120	120	120	120	114	108	105	105	105	105	105	105	105	105
19	120	120	120	120	120	120	120	120	120	120	117	112	105	103	100	100	100	100	100	100	100
20	120	120	120	120	120	120	120	120	120	120	114	108	105	100	96	94	94	94	94	94	94
21	120	120	120	120	120	120	120	120	120	117	112	108	103	100	94	91	88	88	88	88	88
22	120	120	120	120	120	120	120	120	120	114	112	105	103	96	91	88	85	82	82	82	82
23	120	120	120	120	120	120	120	120	120	114	108	103	100	94	91	85	82	79	77	77	77
24	120	120	120	120	120	120	120	120	117	112	105	103	96	94	88	85	79	77	73	70	70
25	120	120	120	120	120	120	120	120	114	108	105	100	96	91	88	82	79	77	70	67	65
26	120	120	120	120	120	120	120	117	112	108	103	100	94	91	85	82	77	73	70	65	62
27	120	120	120	120	120	120	120	114	112	105	100	96	91	88	82	79	77	70	67	65	62
28	120	120	120	120	120	120	120	114	108	103	100	94	91	85	82	79	73	70	67	62	59
29	120	120	120	120	120	120	117	112	105	103	96	94	88	85	79	77	73	67	65	62	59
30	120	120	120	120	120	120	114	108	105	100	96	91	88	82	79	73	70	67	65	59	56
31	120	120	120	120	120	117	112	108	103	100	94	88	85	82	77	73	70	65	62	59	56
32	120	120	120	120	120	114	112	105	100	96	91	88	82	79	77	70	67	65	62	56	53
33	120	120	120	120	120	114	108	103	100	94	91	85	82	79	73	70	67	62	59	56	53
34	120	120	120	120	117	112	105	103	96	94	88	85	79	77	73	67	65	62	59	56	50
35	120	120	120	120	114	108	105	100	96	91	88	82	79	73	70	67	65	59	56	53	50
36	120	120	120	117	112	108	103	100	94	88	85	82	77	73	70	65	62	59	56	53	50
37	120	120	120	117	112	105	100	96	91	88	82	79	77	70	67	65	62	56	53	50	47
38	120	120	120	114	108	103	100	94	91	85	82	77	73	70	67	62	59	56	53	50	47
39	120	120	117	112	105	103	96	94	88	85	79	77	73	67	65	62	59	56	50	47	44
40	120	120	114	108	105	100	96	91	88	82	79	73	70	67	65	59	56	53	50	47	44
41	120	117	112	108	103	100	94	88	85	82	77	73	70	65	62	59	56	53	47	44	41
42	120	117	112	105	100	96	91	88	82	79	77	70	67	65	62	56	53	50	47	44	41
43	117	114	108	103	100	94	91	85	82	79	73	70	67	62	59	56	53	50	47	44	38
44	117	112	105	103	96	94	88	85	79	77	73	67	65	62	59	53	50	47	44	41	38
45	114	111	105	100	96	91	88	82	79	73	70	67	65	59	56	53	50	47	44	41	38

Legend: t = Fresh air temperature in °C  
x = Fresh air humidity in g/kg

Table F5: Cooling capacities in kW of the free and adiabatic cooling ( $Q_f$ )

Extract air: 36 °C      Supply air: 23 °C       $\Delta t = 13 \text{ K}$        $Q_{\text{tot}} = 112 \text{ kW}$

Fresh air																					
t \ x	0,1	1	2	3	4	5	6	7	8	9	10	11	12	13	14	15	16	17	18	19	20
≤16	112	112	112	112	112	112	112	112	112	112	112	112	112	112	112	112	112	112	112	112	112
17	112	112	112	112	112	112	112	112	112	112	112	112	112	111	111	111	111	111	111	111	111
18	112	112	112	112	112	112	112	112	112	112	112	112	108	105	105	105	105	105	105	105	105
19	112	112	112	112	112	112	112	112	112	112	112	112	105	103	100	100	100	100	100	100	100
20	112	112	112	112	112	112	112	112	112	112	112	108	105	100	96	94	94	94	94	94	94
21	112	112	112	112	112	112	112	112	112	112	112	108	103	100	94	91	88	88	88	88	88
22	112	112	112	112	112	112	112	112	112	112	112	105	103	96	91	88	85	82	82	82	82
23	112	112	112	112	112	112	112	112	112	112	108	103	100	94	91	85	82	79	77	77	77
24	112	112	112	112	112	112	112	112	112	112	105	103	96	94	88	85	79	77	73	70	70
25	112	112	112	112	112	112	112	112	112	108	105	100	96	91	88	82	79	77	70	67	65
26	112	112	112	112	112	112	112	112	112	108	103	100	94	91	85	82	77	73	70	65	62
27	112	112	112	112	112	112	112	112	112	105	100	96	91	88	82	79	77	70	67	65	62
28	112	112	112	112	112	112	112	112	108	103	100	94	91	85	82	79	73	70	67	62	59
29	112	112	112	112	112	112	112	112	105	103	96	94	88	85	79	77	73	67	65	62	59
30	112	112	112	112	112	112	112	108	105	100	96	91	88	82	79	73	70	67	65	59	56
31	112	112	112	112	112	112	112	108	103	100	94	88	85	82	77	73	70	65	62	59	56
32	112	112	112	112	112	112	112	105	100	96	91	88	82	79	77	70	67	65	62	56	53
33	112	112	112	112	112	112	108	103	100	94	91	85	82	79	73	70	67	62	59	56	53
34	112	112	112	112	112	112	105	103	96	94	88	85	79	77	73	67	65	62	59	56	50
35	112	112	112	112	112	108	105	100	96	91	88	82	79	73	70	67	65	59	56	53	50
36	112	112	112	112	112	108	103	100	94	88	85	82	77	73	70	65	62	59	56	53	50
37	112	112	112	112	112	105	100	96	91	88	82	79	77	70	67	65	62	56	53	50	47
38	112	112	112	112	108	103	100	94	91	85	82	77	73	70	67	62	59	56	53	50	47
39	112	112	112	112	105	103	96	94	88	85	79	77	73	67	65	62	59	56	50	47	44
40	112	112	112	108	105	100	96	91	88	82	79	73	70	67	65	59	56	53	50	47	44
41	112	112	112	108	103	100	94	88	85	82	77	73	70	65	62	59	56	53	47	44	41
42	112	112	112	105	100	96	91	88	82	79	77	70	67	65	62	56	53	50	47	44	41
43	112	112	108	103	100	94	91	85	82	79	73	70	67	62	59	56	53	50	47	44	38
44	112	112	105	103	96	94	88	85	79	77	73	67	65	62	59	53	50	47	44	41	38
45	112	111	105	100	96	91	88	82	79	73	70	67	65	59	56	53	50	47	44	41	38

Legend: t = Fresh air temperature in °C  
x = Fresh air humidity in g/kg

Table F6: Cooling capacities in kW of the free and adiabatic cooling ( $Q_f$ )



Extract air: 36 °C

Supply air: 24 °C

$\Delta t = 12 \text{ K}$

$Q_{\text{tot}} = 103 \text{ kW}$

Fresh air																					
t \ x	0,1	1	2	3	4	5	6	7	8	9	10	11	12	13	14	15	16	17	18	19	20
≤18	103	103	103	103	103	103	103	103	103	103	103	103	103	103	103	103	103	103	103	103	103
19	103	103	103	103	103	103	103	103	103	103	103	103	103	103	100	100	100	100	100	100	100
20	103	103	103	103	103	103	103	103	103	103	103	103	103	100	96	94	94	94	94	94	94
21	103	103	103	103	103	103	103	103	103	103	103	103	103	100	94	91	88	88	88	88	88
22	103	103	103	103	103	103	103	103	103	103	103	103	103	96	91	88	85	82	82	82	82
23	103	103	103	103	103	103	103	103	103	103	103	103	100	94	91	85	82	79	77	77	77
24	103	103	103	103	103	103	103	103	103	103	103	103	96	94	88	85	79	77	73	70	70
25	103	103	103	103	103	103	103	103	103	103	103	100	96	91	88	82	79	77	70	67	65
26	103	103	103	103	103	103	103	103	103	103	103	100	94	91	85	82	77	73	70	65	62
27	103	103	103	103	103	103	103	103	103	103	100	96	91	88	82	79	77	70	67	65	62
28	103	103	103	103	103	103	103	103	103	103	100	94	91	85	82	79	73	70	67	62	59
29	103	103	103	103	103	103	103	103	103	103	96	94	88	85	79	77	73	67	65	62	59
30	103	103	103	103	103	103	103	103	103	100	96	91	88	82	79	73	70	67	65	59	56
31	103	103	103	103	103	103	103	103	103	100	94	88	85	82	77	73	70	65	62	59	56
32	103	103	103	103	103	103	103	103	100	96	91	88	82	79	77	70	67	65	62	56	53
33	103	103	103	103	103	103	103	103	100	94	91	85	82	79	73	70	67	62	59	56	53
34	103	103	103	103	103	103	103	103	96	94	88	85	79	77	73	67	65	62	59	56	50
35	103	103	103	103	103	103	103	100	96	91	88	82	79	73	70	67	65	59	56	53	50
36	103	103	103	103	103	103	103	100	94	88	85	82	77	73	70	65	62	59	56	53	50
37	103	103	103	103	103	103	100	96	91	88	82	79	77	70	67	65	62	56	53	50	47
38	103	103	103	103	103	103	100	94	91	85	82	77	73	70	67	62	59	56	53	50	47
39	103	103	103	103	103	103	96	94	88	85	79	77	73	67	65	62	59	56	50	47	44
40	103	103	103	103	103	100	96	91	88	82	79	73	70	67	65	59	56	53	50	47	44
41	103	103	103	103	103	100	94	88	85	82	77	73	70	65	62	59	56	53	47	44	41
42	103	103	103	103	100	96	91	88	82	79	77	70	67	65	62	56	53	50	47	44	41
43	103	103	103	103	100	94	91	85	82	79	73	70	67	62	59	56	53	50	47	44	38
44	103	103	103	103	96	94	88	85	79	77	73	67	65	62	59	53	50	47	44	41	38
45	103	103	103	100	96	91	88	82	79	73	70	67	65	59	56	53	50	47	44	41	38

Legend: t = Fresh air temperature in °C  
x = Fresh air humidity in g/kg

Table F7: Cooling capacities in kW of the free and adiabatic cooling ( $Q_f$ )

2.2 Mechanical cooling

Q <sub>M</sub>	Flow/Return			
	8/14 °C		14/20 °C	
	m <sub>w</sub>	Δp <sub>w</sub>	m <sub>w</sub>	Δp <sub>w</sub>
kW	l/h	kPa	l/h	kPa
3	538	0.04	537	0.05
4	671	0.07	670	0.07
5	782	0.09	781	0.09
6	938	0.12	937	0.12
7	1073	0.16	1071	0.16
8	1251	0.21	1249	0.21
9	1471	0.28	1469	0.28
10	1564	0.31	1561	0.31
11	1720	0.37	1717	0.37
12	1876	0.44	1873	0.44
13	2033	0.51	2030	0.50
14	2189	0.58	2186	0.58
15	2408	0.70	2404	0.68
16	2533	0.76	2529	0.75
17	2674	0.84	2670	0.83
18	2799	0.92	2795	0.90
19	2971	1.02	2966	1.00
20	3127	1.13	3122	1.10
21	3331	1.26	3325	1.23
22	3440	1.34	3435	1.31
23	3597	1.46	3591	1.42
24	3722	1.55	3716	1.51
25	3909	1.70	3903	1.65
26	4128	1.88	4122	1.82
27	4253	1.99	4247	1.92
28	4378	2.09	4371	2.02
29	4535	2.23	4528	2.16
30	4644	2.33	4637	2.25
31	4848	2.53	4840	2.43
32	5051	2.73	5043	2.62
33	5176	2.85	5168	2.74
34	5317	3.00	5308	2.88

Legend: Q<sub>M</sub> = Mechanical cooling capacity per unit  
(100 % sensitive to max. 10 g/kg extract air humidity)  
m<sub>w</sub> = Water quantity  
Δp<sub>w</sub> = Water-side pressure loss

Reference: Supply air flow rate 25750 m<sup>3</sup>/h  
Water/glycol mixture with 30 % glycol

Q <sub>M</sub>	Flow/Return			
	8/14 °C		14/20 °C	
	m <sub>w</sub>	Δp <sub>w</sub>	m <sub>w</sub>	Δp <sub>w</sub>
kW	l/h	kPa	l/h	kPa
35	5442	3.13	5433	3.00
36	5551	3.24	5542	3.11
37	5786	3.50	5777	3.35
38	5973	3.71	5964	3.55
39	6083	3.84	6073	3.67
40	6255	4.04	6245	3.86
41	6364	4.17	6354	3.99
42	6599	4.46	6588	4.26
43	6755	4.66	6744	4.44
44	6849	4.78	6838	4.56
45	6990	4.96	6979	4.73
46	7193	5.23	7182	4.98
47	7381	5.48	7369	5.22
48	7506	5.66	7494	5.38
49	7662	5.88	7650	5.58
50	7803	6.08	7790	5.77
51	7975	6.33	7962	6.00
52	8131	6.56	8118	6.22
53	8288	6.79	8274	6.44
54	8444	7.03	8431	6.66
55	8601	7.27	8587	6.89
56	8804	7.59	8790	7.18
57	8913	7.77	8899	7.35
58	9101	8.07	9086	7.63
59	9179	8.20	9164	7.75
60	9382	8.54	9367	8.06
61	9601	8.91	9586	8.41
62	9695	9.07	9680	8.56
63	9852	9.34	9836	8.81
64	10008	9.61	9992	9.06
65	10211	9.98	10195	9.40
66	10321	10.18	10304	9.58

Legend: Q<sub>M</sub> = Mechanical cooling capacity per unit  
(100 % sensitive to max. 10 g/kg extract air humidity)  
m<sub>w</sub> = Water quantity  
Δp<sub>w</sub> = Water-side pressure loss

Reference: Supply air flow rate 25750 m<sup>3</sup>/h  
Water/glycol mixture with 30 % glycol

Q <sub>M</sub>	Flow / Return			
	8/14 °C		14/20 °C	
	m <sub>w</sub>	Δp <sub>w</sub>	m <sub>w</sub>	Δp <sub>w</sub>
kW	l/h	kPa	l/h	kPa
67	10493	10.49	10476	9.88
68	10586	10.66	10569	10.04
69	10790	11.04	10772	10.39
70	11009	11.46	10991	10.77
71	11103	11.64	11085	10.94
72	11259	11.95	11241	11.22
73	11447	12.32	11428	11.56
74	11603	12.63	11584	11.85
75	11728	12.88	-	-
76	11884	13.20	-	-
77	12041	13.52	-	-
78	12197	13.84	-	-
79	12354	14.17	-	-
80	12510	14.51	-	-
81	12666	14.84	-	-
82	12823	15.18	-	-
83	12979	15.53	-	-
84	13135	15.87	-	-
85	13292	16.22	-	-
86	13448	16.58	-	-
87	13604	16.93	-	-
88	13761	17.29	-	-
89	13917	17.66	-	-
90	14074	18.02	-	-
91	14230	18.40	-	-

Legend: Q<sub>M</sub> = Mechanical cooling capacity per unit  
(100 % sensitive to max. 10 g/kg extract air humidity)  
m<sub>w</sub> = Water quantity  
Δp<sub>w</sub> = Water-side pressure loss

Reference: Supply air flow rate 25750 m<sup>3</sup>/h  
Water/glycol mixture with 30 % glycol

Table F8: Mechanical cooling capacities per unit

### 3 Recommended extract air humidity

The dimensions of a supply air humidifier supplied by the client depend on the dehumidification capacity of the ServeCool unit, and thus the extract air humidity. Hoval recommends complying with the extract air humidities indicated in Diagram F1. If these set values are complied with, the dehumidification capacity is 5 kg/h at most.



#### Note

Set the set value for the extract air humidity at low fresh air temperatures acc. to Diagram F1.

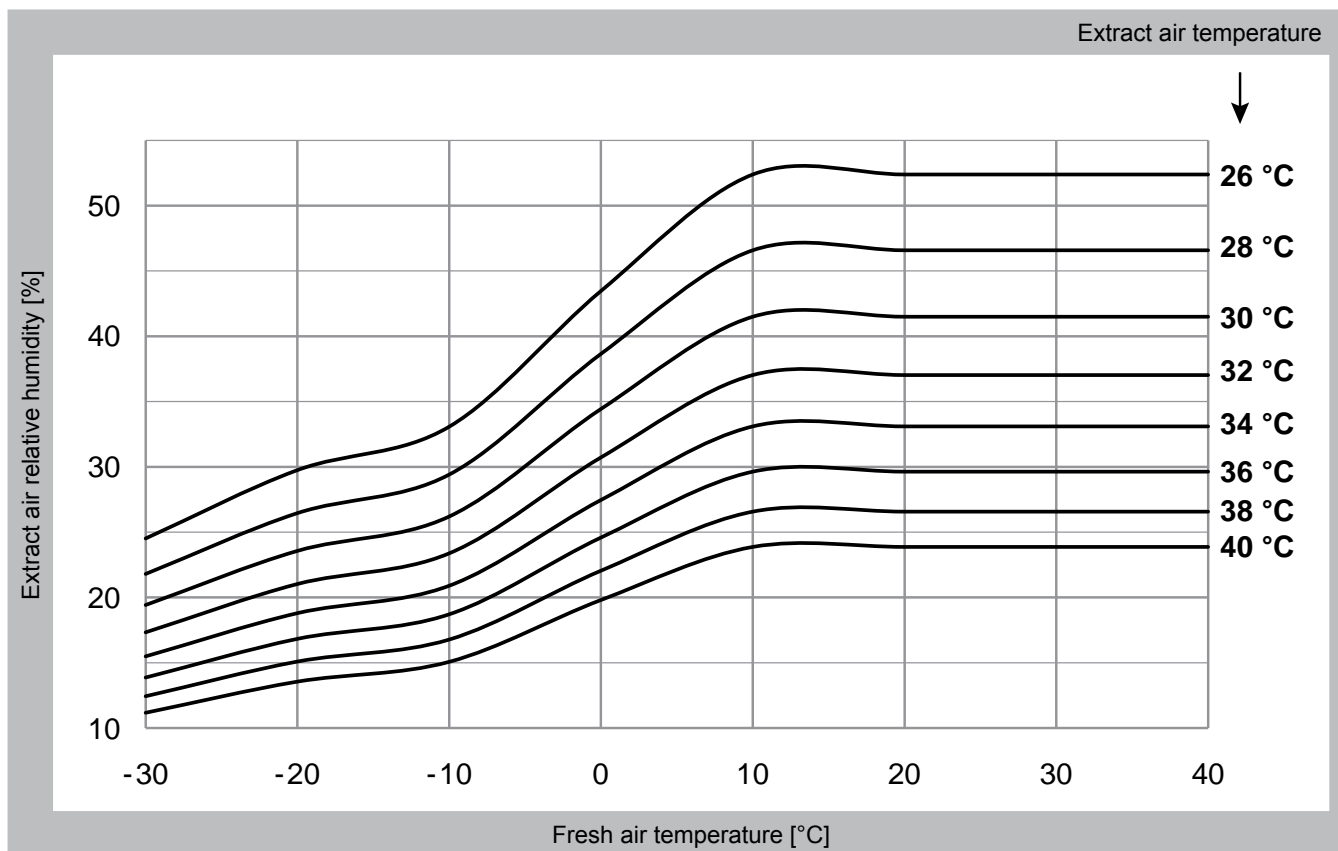

Reference: Air pressure 1013 hPa

Diagram F1: Recommended extract air humidities depending on the fresh air temperature

## 4 Maintenance schedule

Activity	Interval
Change the filter (extract air filter, fresh air filter)	When the 'Filter' alarm is displayed, at least annually
Check the total colony count of the circulating water using Dip slides	Every 3 months (during summer operation)
Check the function of the discharge and trap	Every 6 months
Drain and clean the adiabatic system, clean the water filter	Every 6 months (before and after summer operation)
Comprehensive functional check and cleaning of the unit (fans, actuators, adiabatic pump, spray nozzles, cooling valve, ...)	Annually



### Note

Check whether additional activities are required to comply with national regulations (e.g. hygiene inspections acc. to VDI 6022, ensuring hygienic operation of evaporative cooling systems acc. to VDI 2047-2).

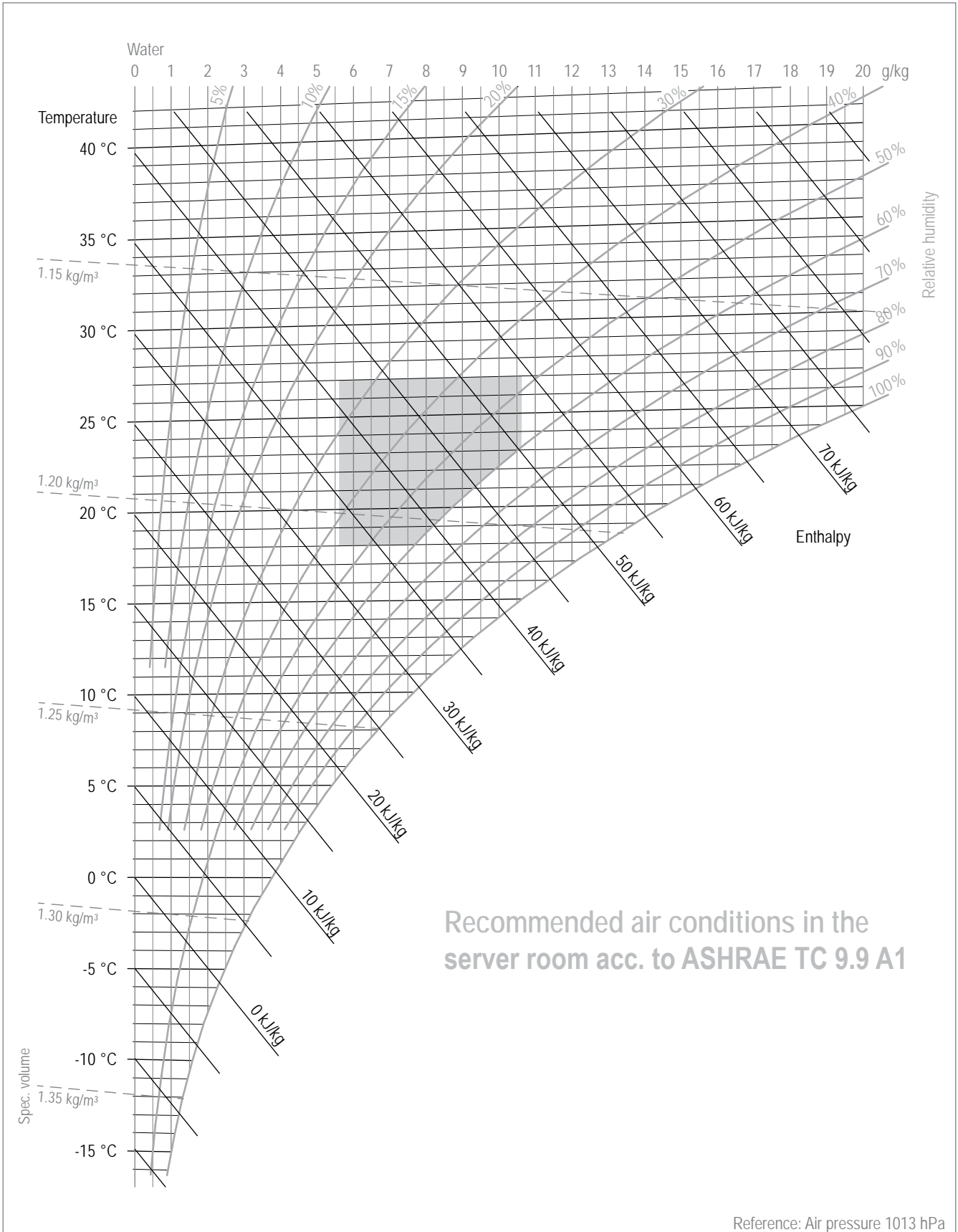



## Responsibility for energy and environment

The Hoval brand is internationally known as one of the leading suppliers of indoor climate control solutions. More than 65 years of experience have given us the necessary capabilities and motivation to continuously develop exceptional solutions and technically advanced equipment. Maximising energy efficiency and thus protecting the environment are both our commitment and our incentive. Hoval has established itself as an expert provider of intelligent heating and ventilation systems that are exported to over 50 countries worldwide.

International  
Hoval Aktiengesellschaft  
Austrasse 70  
9490 Vaduz, Liechtenstein  
Tel. +423 399 24 00  
Fax +423 399 27 31

United Kingdom  
Hoval Ltd.  
Northgate, Newark  
Nottinghamshire  
NG24 1JN  
Tel. 01636 672711  
Fax 01636 673532



### Hoval heating technology

As a full range supplier Hoval helps its customers to select innovative system solutions for a wide range of energy sources, such as heat pumps, biomass, solar energy, gas, oil and district heating. Services range from small commercial to large-scale industrial projects.



### Hoval comfort ventilation

Increased comfort and more efficient use of energy from private housing to industrial halls: our comfort ventilation products provide fresh, clean air for living and working space. Our innovative system for a healthy room climate uses heat and moisture recovery, while at the same time protecting energy resources and providing a healthier environment.



### Hoval indoor climate systems

Indoor climate systems ensure top air quality and economical usability. Hoval has been installing decentralised systems for many years. The key is to combine multiple combinations of air-conditioners that can be controlled separately or together as a single system. This enables Hoval to respond flexibly to a wide range of requirements for heating, cooling and ventilation.



### Hoval heat recovery

Efficient use of energy due to heat recovery. Hoval offers two different solutions: plate heat exchangers as a recuperative system and rotary heat exchangers as a regenerative system.