

# RPF

**High performance heat recovery unit with cross-current recuperator.**  
**Nominal air flow from 790 to 4250 m<sup>3</sup>/h.**



- **CROSS-CURRENT HEAT RECOVERY WITH PERFORMANCES SUPERIOR THAN 90%**
- **PLUG FANS COUPLED WITH EC BRUSHLESS MOTORS FOR ENERGY COSTS REDUCTION**

## Features

• Heat recovery units **RPF** have been designed for commercial applications and permits to combine an excellent ambient comfort with a sure energy saving. Always more in the modern plant design there is the demand to have a Controlled Mechanical Ventilation, which implies the expulsion of conditioned air, determining a higher consumption of energy and consequently an increase of prices.

The units **RPF thanks to the cross-current heat recuperator** permit to save more than 90% of energy which otherwise would be lost with expelled stuffy air.

**RPF** could be integrated with traditional systems realized with fan coils, chillers, and could work both in winter and in summer. This series is indicated for both horizontal and vertical installation.

### Configurations

- **RPF\_O** Horizontal right supply (not available for size 42)
- **RPF\_P** Horizontal left supply (not available for size 42)
- **RPF\_V** Vertical right supply
- **RPF\_Z** Vertical left supply

Each of the different configurations could be further customized thanks to the choice of the accessories (**please refer to the technical documentation**)

- **The structure is formed by aluminium profiles with thermic cut**, connected by nylon angles charged with glassfibre. The sealing panels, of 50 mm thickness, are of the sandwich type in pre-painted plate RAL 9002 (external) and galvanized sheet iron (internal) insulated with polyurethane with

density 45 kg/m<sup>3</sup>. The expandent of the polyurethane foam is based on water permitting to reach GWP=0 (Global Warming Potential). The casing is in fire reaction class M1 according to the French regulation NF P 92-512:1986. Removable panels are also foreseen to access to internal components, equipped with safety locks, condensate drain and internal modulating rolling shutter of motorized and controlled bypass for free-cooling.

- Fans of supply and extract of plug-fan-type with synchronous motor with electronic control permanent magnetos (EC). The impellers are oriented in such a way to grant an optimal air flow which goes through the internal components, with the minimum noise.
- Air filtration with a filter with G4 efficiency (according to EN779) with low pressure drops on extracted air flow and a compact filter and with efficiency F7 (according to EN779) having a large filtrating surface made of glass microfibre paper, inserted in the intake flow. The two typologies of filters are positioned upstream of the components to be protected, in order to grant low pressure drops, having a large surface available. The filtrating cells are fixed on a proper bearing frame to avoid any by-pass of non-treated air. Their extractability is guaranteed from a proper side opening (standard), superior or inferior (optional) [with reference to the horizontal version].
- Static high efficiency cross-current heat recovery unit with high efficiency and aluminium plate. The heat recovery unit guarantees the non-contamination of air flows, because the plates are properly sealed.

Its performance is not inferior to 90% (EN308) in function to the external conditions: Air of intake: -10°C/90% - Air of extract 20°C/50% and equal capacities between supply and extract. It is included also the function of automatic defrosting made easy by the internal modulating rolling shutter and from the possible modulation with intake flow.

- Regulation  
 Constituted by power electric panel and programmable controller with integrated graphic display. Everything is internally fitted in the unit in an accessible position.  
 The function of regulation are:
  1. Ventilation control (manual control of the standard fans speed);
  2. Thermo-regulation completed with all electric/electronic components (modality of regulation in standard extract);
  3. Integrated logics of energy savings: modulating free-cooling / free-heating, anti-freeze, night cooling, air quality control, dynamic set point, speed economy of ventilation, ranges of time;
  4. Complete interfaceability with BMS systems.

## Functionality and technological advantages

The elimination from closed rooms of the polluting elements, produced mainly from people and the simultaneous external air input, are at the basis of the concept of controlled mechanical ventilation (VMC) of the internal rooms.

The purpose of ventilation is to raise the standard of internal air quality with consequent positive effects for health and productivity of the occupiers. The change of air has positive effects also on the good maintenance of the building. For the building to be requalified, the Controlled Mechanical Ventilation is almost a mandatory choice in order to reach high energy standards, which are imposed by the current legislation.

- **VERY HIGH VENTILATION EFFICIENCY**

Since the ventilation represents one of the major factor of energy consumption, particular attention has been given to the study and to the creation of the ventilation system.

Fans of the plug-fan type with EC brushless motors have been used both in supply and in extraction; they permit high performances and reduced consumptions. Furthermore, compared with the traditional centrifugal fans, they don't have belts or pulleys with consequent easiness of capacity regulation, compactness, versatility, and an easy maintenance.

A particular adaptative logic permits to adjust the effective air capacity required from the system with more consequent advantages in terms of reduction of consumptions.

- **MAXIMUM EFFICIENCIES**

In this context RPF is proposed as the high efficient and performing solution for double flow ventilation systems with heat recovery.

The key-concept on which is based the RPF proposal are:

- Very high efficiency heat recovery attested by EUROVENT certification and maintenance of the complete separation of intake and discharge air flow;
- Reduced ventilation energy consumptions, thanks to a detailed dimensioning of the components in order to have low total values of SFP (Specific Fan Power or rather energy consumption for  $m^3/h$  of total processed capacity);
- High efficiency filtration and low pressure drops;
- Advanced electronic management for the energy saving and of controlling of internal pollutants functions VOC (Volatile Organic Compounds);
- Compactness of dimensions and logic of installation "plug and play".

- **AIR QUALITY IN ROOM**

Particular attention has been given naturally also to the quality of air in the room, standard assigned to filters with efficiency G4 on extracted air flow and on compact filter with efficiency F7 included on intake air flow.

Naturally all these technological advantages are controlled by a thermoregulation of last generation, able to manage the different working procedures; assuring the maximum energy saving in every usage condition by using a proper software.

### Basic configuration

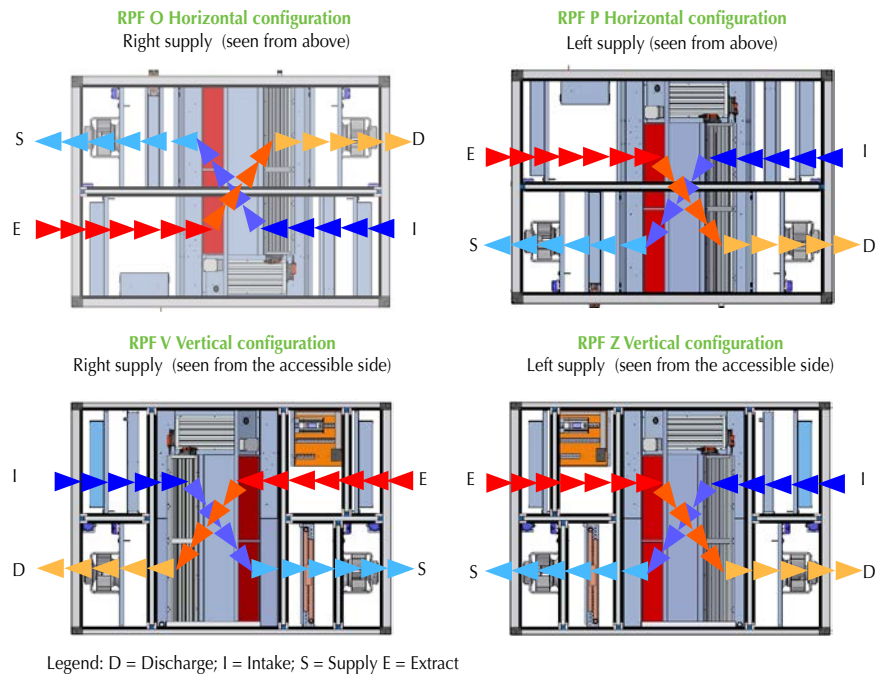

Fans of supply and extract of plug-fan-type with synchronous motor with electronic control permanent magnetos (EC)



Static cross-current high efficiency recuperator with aluminium plates.

## Technical Data

Mod. RPF		008	010	013	020	031	042
Configurations	Horizontal	•	•	•	•	•	-
	Vertical	•	•	•	•	•	•
Nominal air flow (supply/extract)	m <sup>3</sup> /h	790	1000	1300	2000	3100	4250
Minimum air flow (supply/extract)	m <sup>3</sup> /h	200	200	400	1000	1000	1300
Maximum air flow (supply/extract)	m <sup>3</sup> /h	980	1260	1530	2350	3700	4600
Available static pressure (supply/extract)	Pa	200	250	250	250	250	225
Total recovered heating capacity	(1) kW	7,2	9,1	11,8	18,1	28,1	38,5
Performance in intake (EN308)	(1) %	90	90	90	90	90	90
Fans	type	plug-fan	plug-fan	plug-fan	plug-fan	plug-fan	plug-fan
	n°	2	2	2	2	2	2
Fans Total input power	(2) kW	0,31	0,47	0,66	1,16	1,55	2,50
Input power	(2) kW	0,60	1,24	1,26	1,66	5,26	5,26
Total input current	(2) A	4,6	7,5	7,5	9,3	11,1	11,1
Power supply	V/ph/Hz	230/1N/50Hz	230/1N/50Hz	230/1N/50Hz	230/1N/50Hz	400/3/50Hz	400/3/50Hz

### Cooling

(1) Air conditions: Intake 10°C, 90% UR; Extract 20°C, 50% UR

(2) Unit in standard configuration without accessories

**Note:** For further informations please refer to the technical documentation available on the website

## Dimensions (mm)

RPF 008:031

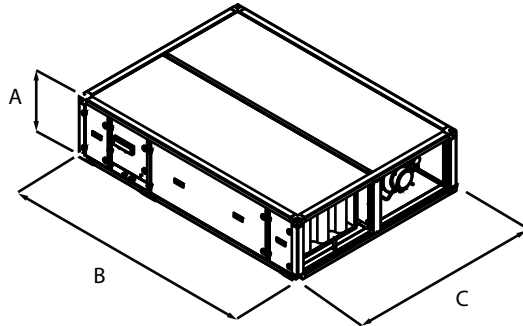

Horizontal Installation

RPF 008:042

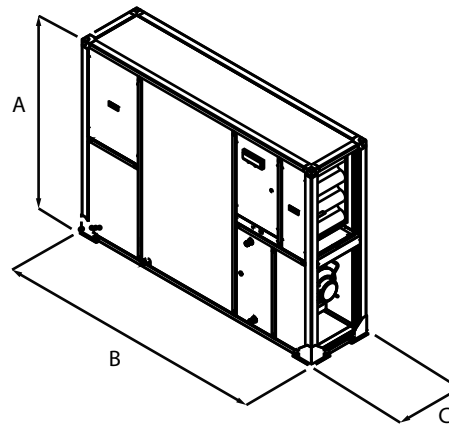

Vertical Installation

Mod. RPF (Horizontal)			008	010	013	020	031	042
Height	(mm)	A	450	450	524	560	700	-
Width	(mm)	B	1915	1915	2174	2334	2654	-
Depth	(mm)	C	1054	1258	1374	1694	1948	-
Weight when empty	(kg)	(2)	194	220	264	328	452	-

Mod. RPF (Vertical)			008	010	013	020	031	042
Height	(mm)	A	1054	1258	1374	1694	1948	1550
Width	(mm)	B	1915	1915	2174	2334	2654	2974
Depth	(mm)	C	450	450	524	560	700	1130
Weight when empty	(kg)	(2)	194	220	264	328	452	585

(2) Standard configuration of unit with accessories

Note: For more information, refer to the selection program Magellano or the technical documentation available on the website