

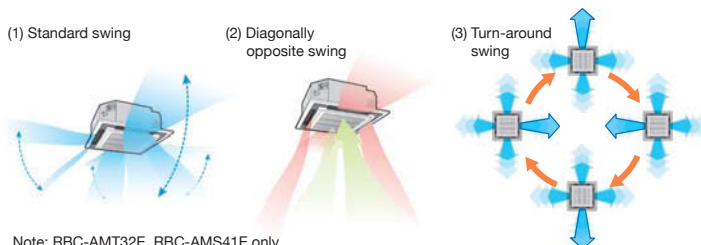

4-way Air Discharge Cassette Type

Individual louver control

The angles of each of the four louver can be set individually
 ⇒ Enables airflow to be adapted to user preferences.



MMU-AP*4HP-E**

Easy installation

The panel is attached using the bolt already installed on the indoor unit.

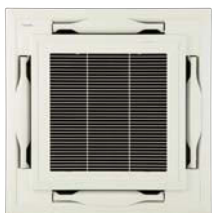

RBC-U31PG(W)-E

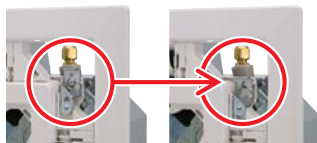

Technical specifications

Model name	MMU-	AP0094HP-E	AP0124HP-E	AP0154HP-E	AP0184HP-E	AP0244HP-E	AP0274HP-E	AP0304HP-E	AP0364HP-E	AP0484HP-E	AP0564HP-E	
Cooling/Heating capacity* ¹	(kW)	2.8/3.2	3.6/4.0	4.5/5.0	5.6/6.3	7.1/8.0	8.0/9.0	9.0/10.0	11.2/12.5	14.0/16.0	16.0/18.0	
Electrical characteristics	Power requirements	1-phase 50Hz 230V (220–240V) / 1-phase 60Hz 220V (Separate power supply for indoor units required.)										
	Power consumption 50 Hz/60 Hz (kW)	0.021/0.021	0.023/0.023	0.026/0.026	0.036/0.036	0.043/0.043	0.088/0.088	0.112/0.112	0.112/0.112	0.112/0.112	0.112/0.112	
Appearance (Ceiling panel)	Model	RBC-U31PG(W)-E										
External dimensions: Main unit (Ceiling panel)*	Height (mm)	256 (30)*							319 (30)*			
	Width (mm)	840 (950)*										
	Depth (mm)	840 (950)*										
Total weight: Main unit (Ceiling panel)*	(kg)	18 (4)*			20 (4)*				25 (4)*			
Fan unit	Standard air flow (High/Mid/Low) (m ³ /h)	800/730/680		930/830/790	1050/920/800	1290/920/800		1320/1110/850	1970/1430/1070	2130/1430/1130	2130/1520/1230	
	Motor output (W)	14				20			68	72		
Connecting pipe	Gas side (mm)	ø9.5		ø12.7			ø15.9					
	Liquid side (mm)	ø6.4					ø9.5					
	Drain port (nominal dia.) (mm)	25 (Polyvinyl chloride tube)										
Sound pressure level* ² (High/Mid/Low)	(dB(A))	30/29/27		31/29/27	32/29/27	35/31/28		38/33/30	43/38/32	46/38/33	46/40/33	

* Figures in parentheses are for ceiling panels.

Note 1 : The capacities are measured under the conditions specified by JIS B 8615 based on the reference piping.

The reference piping consists of 5 m of main piping and 2.5 m of branch piping connected with 0 m height.

Note 2 : The sound level are measured in an anechoic chamber in accordance with JIS B 8616.

Normally, the values measured in the actual operating environment become larger than the indicated values due to the effects of external sound.

Note : Rated conditions Cooling : Indoor air temperature 27°C DB/19°C WB, Outdoor air temperature 35°C DB

Heating : Indoor air temperature 20°C DB, Outdoor air temperature 7°C DB/6°C WB

MMU-AP0094HP-E to MMU-AP0564HP-E

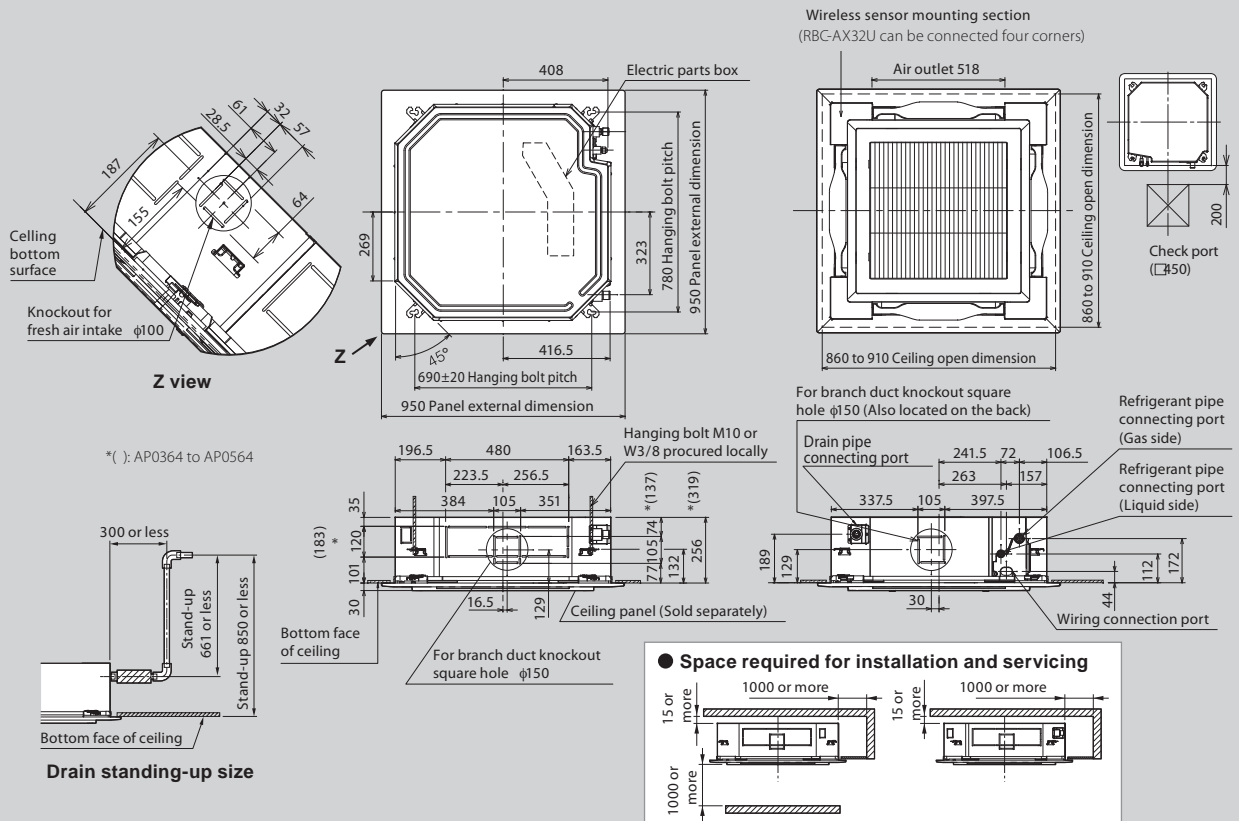

*(): AP0364 to AP0564

* The figure shows the RBC-U31PG(W)-E panel.

Options

