



CRSP

High capacity swirl diffuser with fixed deflectors

Description

CRSP swirl diffuser is specifically constructed to achieve larger air volume capacities with high induction levels. Diffuser is manufactured from PP and has as standard white colour. CRSP has as standard central screw fixing system for a M6 or M8 mounting screw. The diffuser has fixed deflectors to make it an ideal setting for Cooling and heating for ceiling installations of 2.7 to 3.5 meter and above.

Accessories

PB-CRSP, Non insulated side entry plenum box

Dimensions

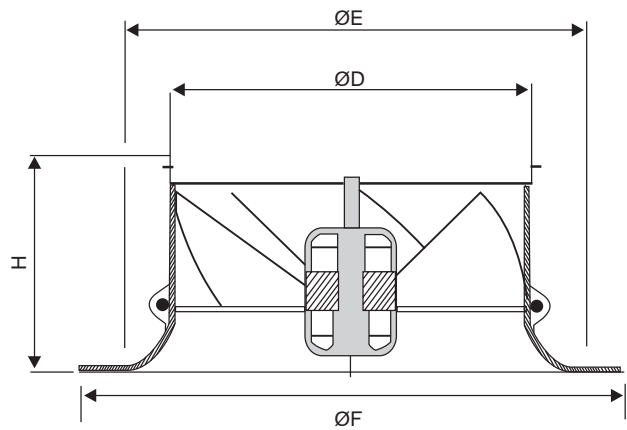

Plenumbox PB-CRSP

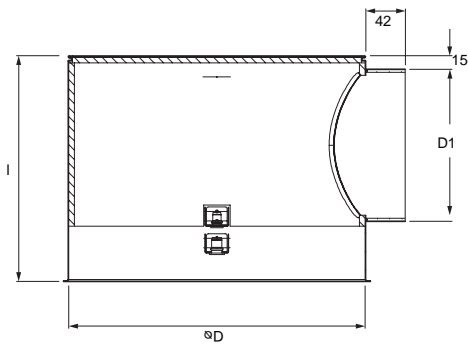

Size	ØD	ØD1	ØE	ØF	G	H
125	123	98	165	190	153	65
160	158	123	225	250	159	85
180	178	158	255	280	159	95
200	198	158	275	300	151	105
250	248	198	350	380	167	130
315	313	248	450	480	176	170
400	398	313	585	610	183	210
500	498	398	735	760	NA	260

The diagram shows

Air volume (l/s and m³/h), total pressure (Pa), throw (l_{0,2}) and sound pressure level [dB(A)].

CRSP-125

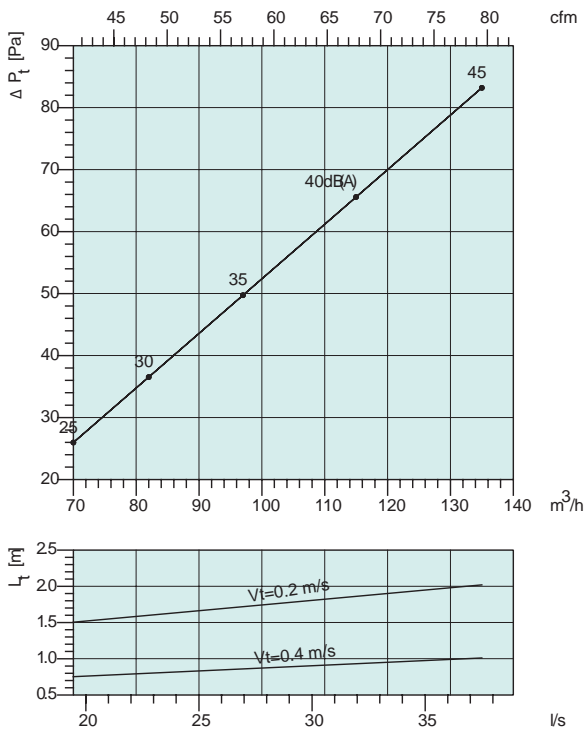

CRSP-160

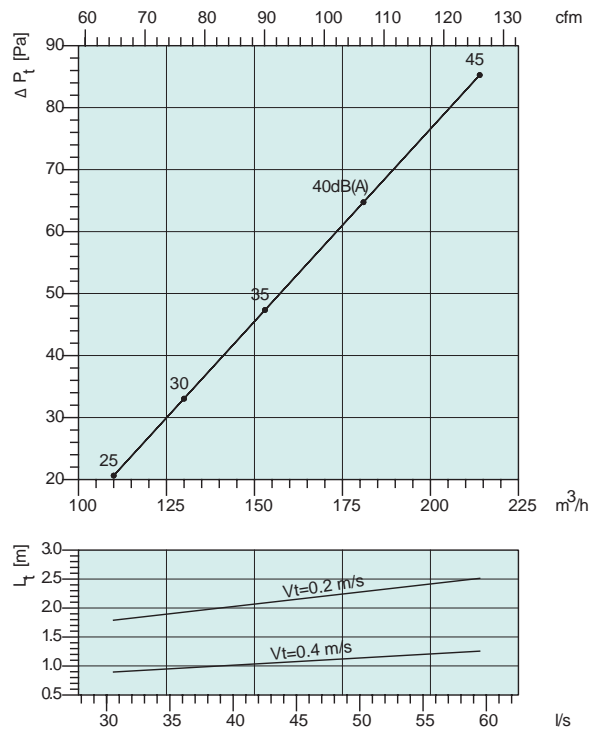

CRSP-180

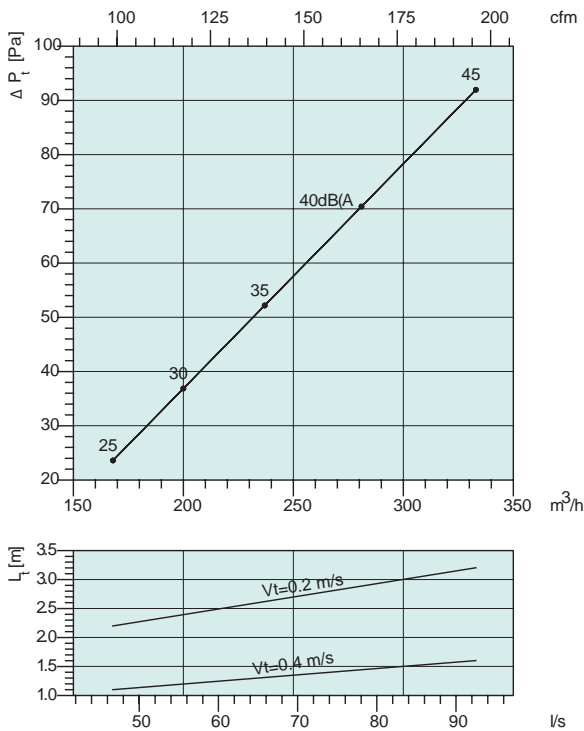

CRSP-250

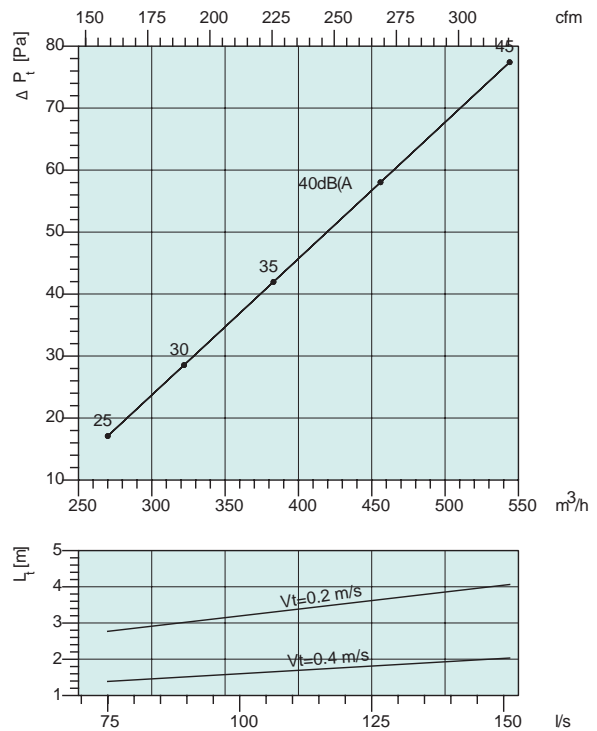

The diagram shows

Air volume (l/s and m³/h), total pressure (Pa), throw (l_{0,2}) and sound pressure level [dB(A)].

