

New Carrier® Dual Stage Relief Economizer

The heating, ventilation and air-conditioning (HVAC) industry has seen many changes over the years to increase energy savings, improve comfort and provide technical solutions to an array of buildings and applications.

One particular product at the forefront of these changes has been Packaged Rooftops with improvements like integrated energy saving air economizers, factory-installed energy recovery, additional dehumidification systems, and devices to help control building pressure.

Today, another new improvement is upon us and Carrier has, once again, taken the lead offering the Dual Stage Relief Economizer.

The patented and exclusive Dual Stage Relief Economizer is designed to provide all the functions of the typical air economizer and adds an additional means to relieve building air pressure when required through the rooftop unit. All of this is achieved without adding an additional power exhaust system or special central exhaust fan system and their related electric power source.

HOW IT WORKS

Economizer Operation

The Carrier energy saving economizer continues to operate as it has in the past. When the outdoor air conditions are favorable, air is brought through the rooftop unit to the conditioned space. When outside air conditions are not favorable, the outside air is controlled to meet the applications minimum air requirement per local codes.

The new feature comes from the way the building pressure is relieved.

Dual Stage Relief Operation

The 1st stage of natural relief is through the new dedicated air chamber, and will provide relief when the building pressure warrants regardless of the economizer damper positions or the indoor fan status. A separate relief duct, installed in the return opening in the curb, must be installed. (See figure 2)

The 2nd stage, which is the conventional natural relief of the past, provides additional pressurization relief when the outside air damper is mostly open and space pressure warrants. (See figure 2)

Figure 1

Conventional relief damper (2nd stage relief) can sometimes be influenced by the evaporator fan. Air relief is provided only when the R/A damper has closed sufficiently to negate the effects of the indoor fan.

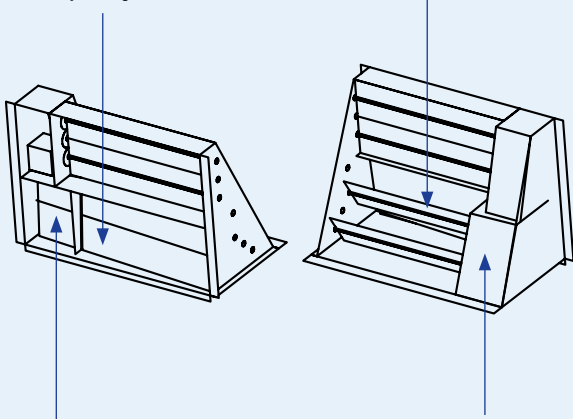

New enclosed space within economizer isolates the 1st stage relief damper from the effects of the indoor fan. The damper always relieves air in direct relation to the building pressure.

Figure 2

Uninsulated 1st stage relief duct should terminate open-ended immediately below the building roof deck in the same plenum space in which the return air duct terminates.

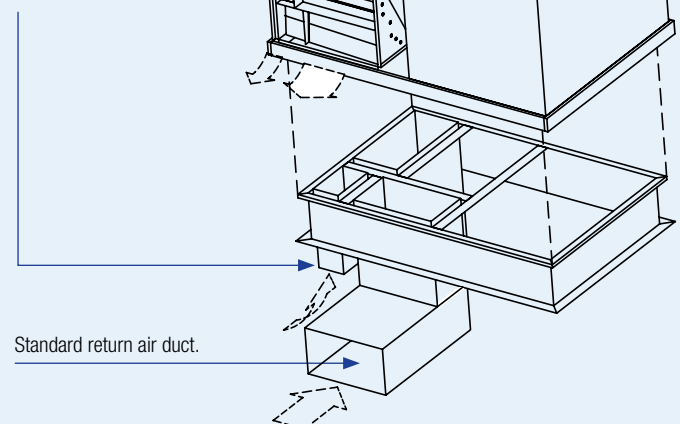

Standard return air duct.

New Carrier® Dual Stage Relief Economizer

The Carrier Dual Stage Relief Economizer is designed for new construction Rooftop applications with vertical air flow duct work.

FEATURES

- Conforms to ASHRAE 90.1-2010 standard – section 6.5.1.1.5 (Relief of excess outdoor air)
- Honeywell W7212/W7220 economizer controller that provides demand control ventilation capability
- Available on popular Carrier Rooftop models:
 - WeatherMaker® 48/50TC04-16 and 50TCQ04-14 models
 - WeatherMaster® 48/50HC04-14 and 50HCQ-12 models
 - WeatherExpert™ 48/50LC04-12 models

BENEFITS

- Added building pressure relief control without power exhaust devices
- Lower installed costs – no additional power source required, one person required to install
- No change in roof curb size
- Lower energy consumption – no need for additional electrical fan or power exhaust motors
- Field tested and proven on actual installations

Vertical Return Air Flow Units – Dual Stage Relief Economizer

48/50TC	50TCQ	48/50HC	50HCQ	48/50LC	48/50KC*	50KCQ*	Description	MicroMetl Model Number
04, 05, 06, 07	04, 05, 06, 07	04, 05, 06	04, 05, 06	04, 05, 06	04, 05, 06	04, 05, 06	Modulating w/W7212 controller and enthalpy sensor. (Standard Leak EconoMiSer IV style).	ECD-SRT12DR-DHE
							Modulating w/W7220 controller and enthalpy sensor. (Standard Leak EconoMiSer X style).	ECD-SRT12DR-D2E
							Modulating w/Belimo actuator and enthalpy sensor. No controller. (Standard Leak EconoMiSer 2 style) For DDC.	ECD-SRT12DR-D0E
08, 09, 12, 14	08, 09, 12	07, 08, 09, 12	07, 08, 09	07	-	-	Modulating w/W7212 controller and enthalpy sensor. (Standard Leak EconoMiSer IV style).	ECD-SRT34DR-DHE
							Modulating w/W7220 controller and enthalpy sensor. (Standard Leak EconoMiSer X style).	ECD-SRT34DR-D2E
							Modulating w/Belimo actuator and enthalpy sensor. No controller. (Standard Leak EconoMiSer 2 style) For DDC.	ECD-SRT34DR-D0E
16	-	14	-	08, 09, 12	-	-	Modulating w/W7212 controller and enthalpy sensor. (Standard Leak EconoMiSer IV style).	ECD-SRT5LDR-DHE
							Modulating w/W7220 controller and enthalpy sensor. (Standard Leak EconoMiSer X style).	ECD-SRT5LDR-D2E
							Modulating w/Belimo sensor. No controller. (Standard Leak EconoMiSer 2 style) For DDC.	ECD-SRT5LDR-D0E
-	14	-	12	-	-	-	Modulating w/W7212 controller and enthalpy sensor. (Standard Leak EconoMiSer IV style).	ECD-SRT5SDR-DHE
							Modulating w/W7220 controller and enthalpy sensor. (Standard Leak EconoMiSer X style).	ECD-SRT5SDR-D2E
							Modulating w/Belimo sensor. No controller. (Standard Leak EconoMiSer 2 style). For DDC.	ECD-SRT5SDR-D0E

* New 14 SEER Models For 2015
 Models with W7220 controller meets California Title 24 Section 120.2 Fault Detection and Diagnostic (FDD).
 Dry bulb sensor versions also available.

1-800-CARRIER

Contact your local Carrier Commercial Expert or local MicroMetl representative for further details.

© Carrier Corporation 2014
 A member of the United Technologies Corporation family.
 Cat. no. 18-811-064

